

TM-132
1st printing

TM

SUBS

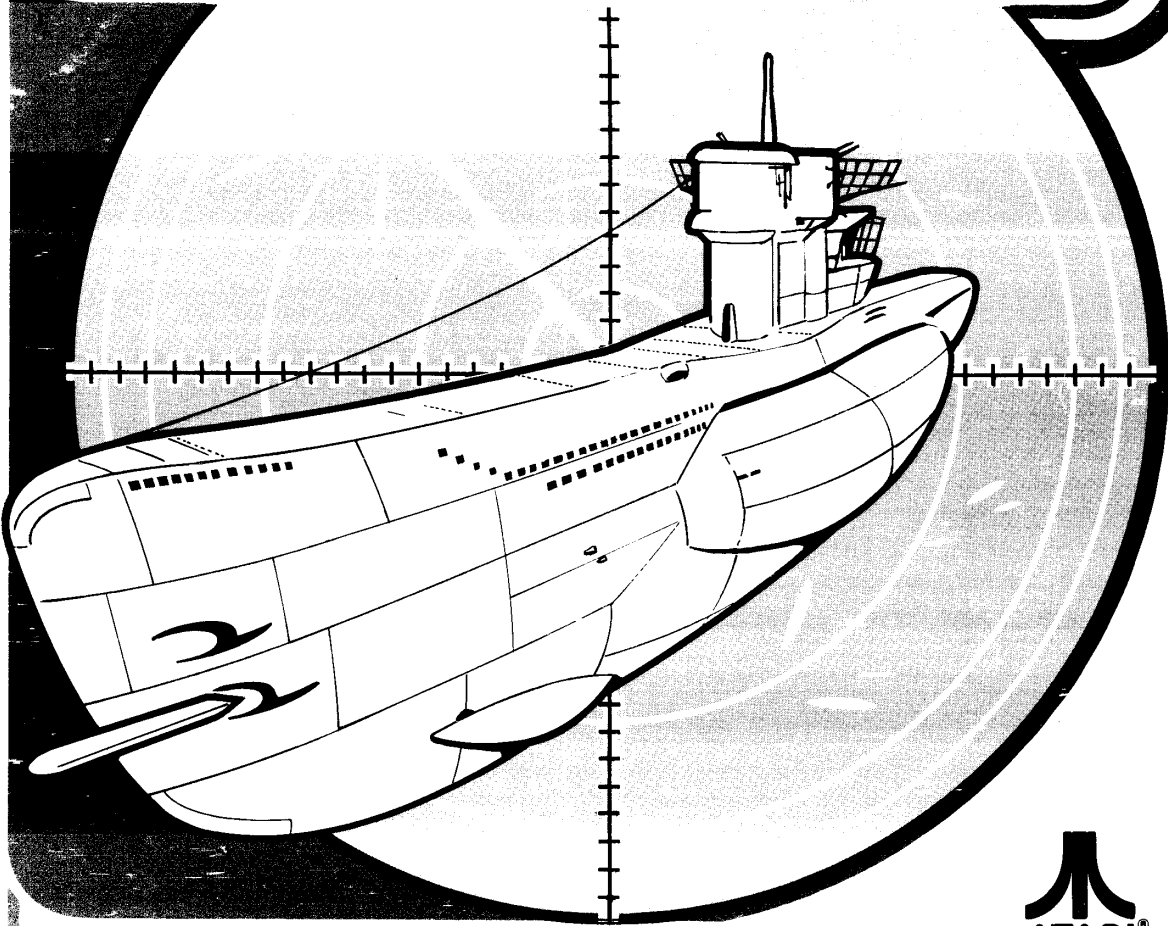

Operation, Maintenance and Service Manual

Complete with Illustrated Parts Catalog



SUBS™

Operation, Maintenance and Service Manual

Complete with Illustrated Parts Catalog

ATARI INC
1265 BORREGAS AVENUE
PO BOX 9027
SUNNYVALE, CALIFORNIA 94086
408.745-2000 • TELEX 35-7488

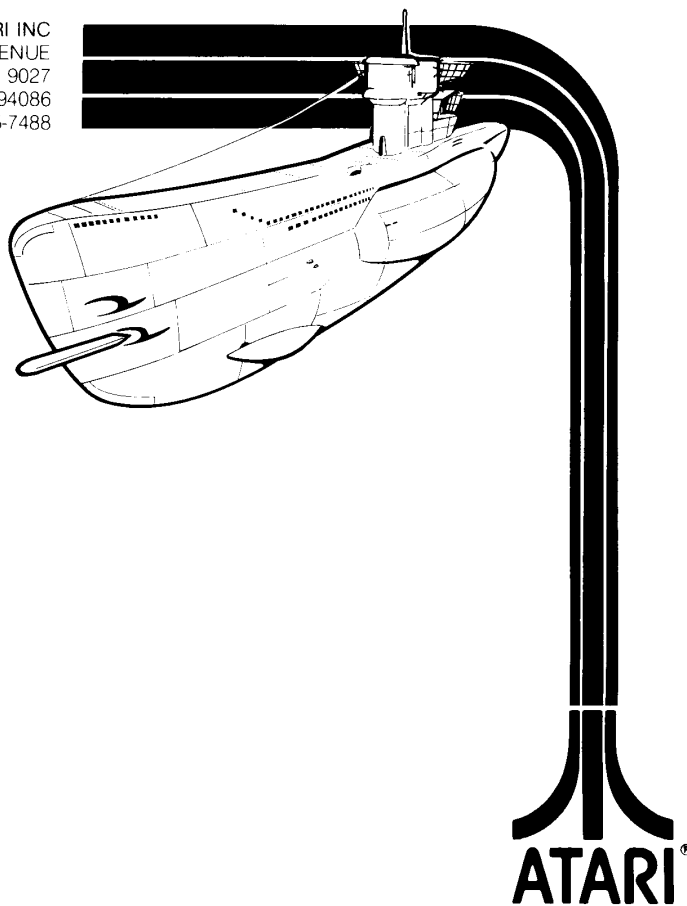

A Warner Communications Company 



table of contents

1 location setup

A. INTRODUCTION	1-1
B. GAME INSPECTION	1-2
C. INSTALLATION REQUIREMENTS	1-4
Low-Voltage Problems	1-4
High-Voltage Problems	1-4
D. INTERLOCK AND POWER ON/OFF SWITCH	1-5
E. SELF-TEST PROCEDURE	1-7
F. VOLUME ADJUSTMENT	1-7
G. OPERATOR OPTIONS	1-7

2 game play

A. INTRODUCTION	2-1
B. ATTRACT MODE	2-2
C. READY-TO-PLAY MODE	2-2
D. PLAY MODE	2-2

3 maintenance and adjustments

A. CLEANING	3-2
B. FUSE REPLACEMENT	3-2
C. VIDEO DISPLAY MONITORS	3-2
Adjustment	3-2
Removal	3-2
D. PLAYER CONTROL PANEL	3-3
E. PLAYER CONTROL REMOVAL	3-3
Start Button	3-3
Steering Assembly	3-4
Torpedo Fire Switch	3-4
F. LOUDSPEAKERS	3-5
G. FRONT PANEL FLUORESCENT LAMP	3-5

table of contents

4 details of electronic operation

A.	GAME PCB POWER DISTRIBUTION	4-3
B.	SYNC CIRCUITRY	4-4
C.	MICROPROCESSOR CIRCUITRY	4-6
	MPU (Microprocessor)	4-6
	Address Decoder	4-7
	Program Memory	4-9
	RAM	4-10
D.	SWITCH AND STEERING INPUT CIRCUITRY	4-10
E.	VIDEO CIRCUITRY	4-13
	Playfield Circuit	4-13
	Motion Circuitry	4-14
	Video Summing Circuit	4-16
F.	AUDIO CIRCUITRY	4-16
	Noise Circuit	4-16
	Sonar Circuit	4-18
	Launch/Crash/Explosion Circuit	4-18

5 illustrated parts catalog

list of tables

Table 1-1	Installation Requirements	1-4
Table 1-2	Self-Test Procedure	1-6
Table 1-3	Identification of Faulty RAM Chips	1-7
Table 1-4	Identification of Faulty ROM Chips	1-8
Table 1-5	Operator Option Settings	1-9
Table 4-1	Memory Map	4-8



list of illustrations

Figure 1-1	Control Panel and Display (Left Player Position)	1-2
Figure 1-2	Game PCB and Power Supply Location	1-3
Figure 1-3	Voltage Selection Plugs	1-4
Figure 1-4	Volume Control, Self-Test Switch and Coin Door Interlock Locations	1-5
Figure 2-1	Attract and Ready-To-Play Modes	2-2
Figure 3-1	Fuse Locations	3-2
Figure 3-2	Monitor Removal	3-3
Figure 3-3	Inside of Player Control Panel	3-4
Figure 3-4	Fluorescent Tube Replacement	3-5
Figure 4-1	Game Power Distribution and Wiring Diagram	4-2
Figure 4-2	Game PCB Power Distribution	4-4
Figure 4-3	Sync Circuitry	4-5
Figure 4-4	Microprocessor	4-6
Figure 4-5	Address Decoder	4-7
Figure 4-6	Program Memory	4-9
Figure 4-7	RAM	4-11
Figure 4-8	Switch and Steering Input	4-12
Figure 4-9	Playfield Circuit	4-13
Figure 4-10	Motion Circuit	4-15
Figure 4-11	Video Summing Circuit	4-16
Figure 4-12	Audio Circuitry	4-17
Figure 5-1	Final Assembly	5-2
Figure 5-2	Control Panel Assembly	5-8
Figure 5-3	Housing Assembly	5-10
Figure 5-4	Fluorescent Light Assembly	5-11
Figure 5-5	Subs PCB Assembly	5-12
Figure 5-6	Type B Power Supply Assembly	5-18
Figure 5-7	Dual Audio Amplifier PCB Assembly	5-20
Figure 5-8	Coin Door Assembly	5-22
Figure 5-9	Steering Wheel Assembly	5-24
Figure 5-10	Fire Button Assembly	5-26
Figure 5-11	Zenith Monitor Assembly	5-27

location setup

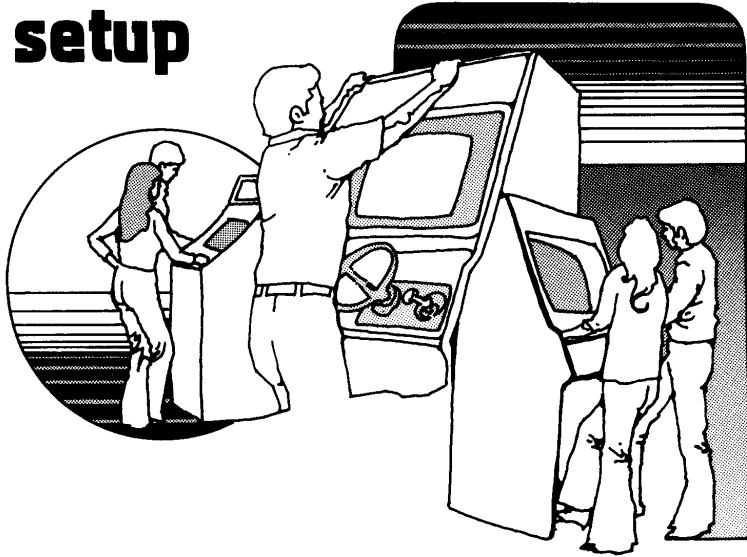

a. introduction

Subs is a one- or two- player, coin-operated electronic game that simulates undersea warfare between two submarines armed with torpedos. It is packaged in a distinctively styled upright cabinet that stands directly on the floor. Two 12-inch video monitors (one for each player) are mounted in the top portion of the cabinet so that neither player can see the other's screen. If only one player is participating, the game computer provides the opposition.

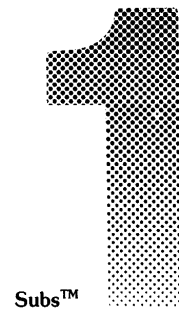

A graphic overlay placed over each screen includes a sonar window. In this window the monitor displays the enemy submarine. A realistic sonar ping sound accompanies each sweep of the sonar display.

A two-coin-mechanism coin door is located on the front panel of the game between the two player stations. The coin box is directly beneath and behind the coin door. Figure 1-1 shows the left player position controls and video display.

b. game inspection

This new game is ready to play upon removal from the shipping carton. However, your careful inspection is needed to supply the final touch of quality control. Please follow these steps to help us insure that your new game was delivered to you in good condition.

NOTE

Do not plug the game in yet!

1. Examine the exterior of the game cabinet for dents, chips, or broken parts.
2. Unlock and open the rear access panel of the cabinet and inspect the interior of the game as follows:
 - a. Check that all plug-in connectors (on the game harness) are firmly seated.
 - b. Remove the game Printed Circuit Board (PCB) as follows:
 - Remove the screw on the top of the PCB (see Figure 1-2).
 - Unplug the edge connector carefully. DO NOT APPLY BENDING FORCE ON THE PCB.
 - Slide the PCB out of its slots.

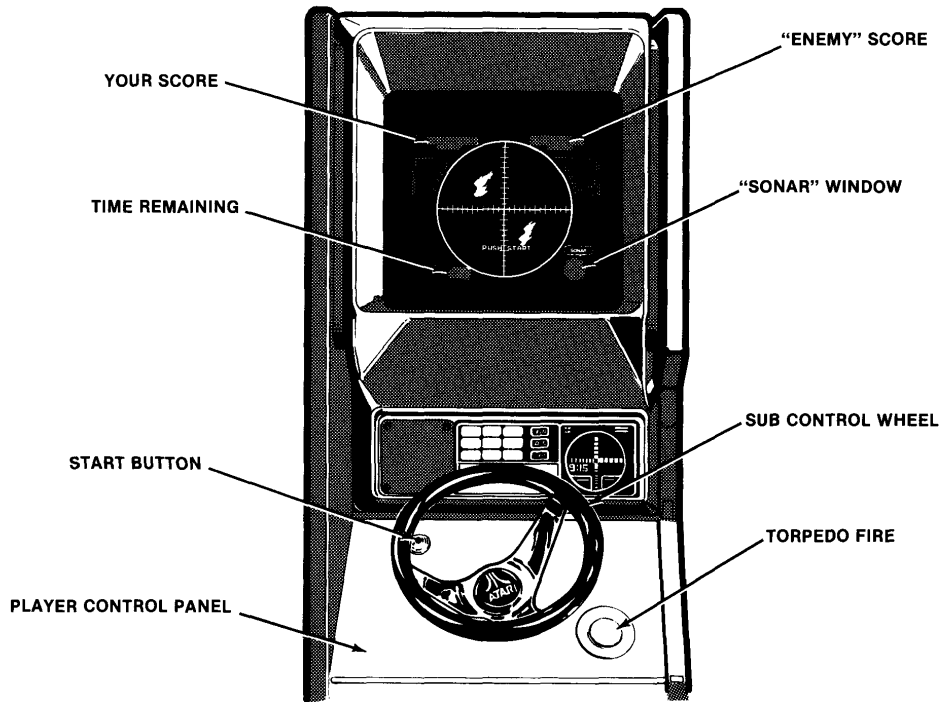

Figure 1-1 Control Panel and Display
Left Player Position

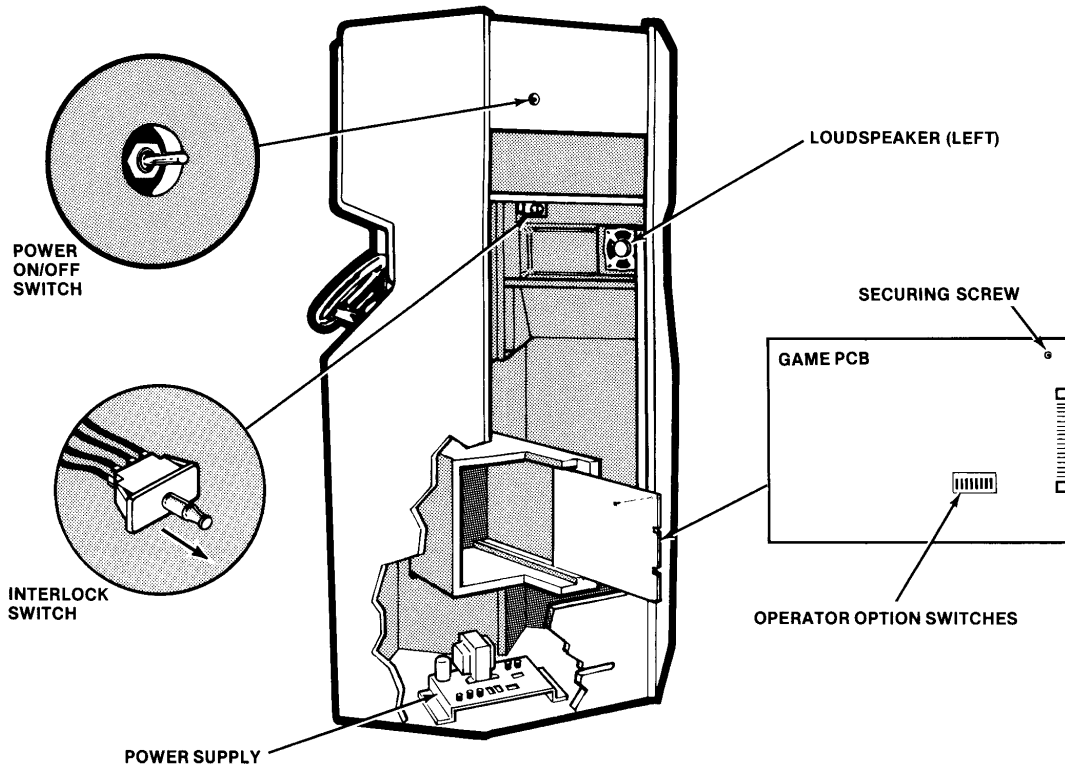

Figure 1-2 Game PCB and Power Supply Location

- c. Verify that all integrated circuits (ICs) are firmly seated in their sockets or soldered in place. You should eliminate any foreign material such as loose bits of wire or solder splashes that could cause unwanted conductive paths.
 - d. Note the location of the game's serial number—it is on the metallic label in the upper left corner of the cabinet. A serial number (not necessarily the same one) appears in the corner of the game PCB that is between the two edge connectors. A drawing of this is on the inside front cover page. Please mention this number whenever you call your distributor for service.
 - e. Carefully slide the PCB back into its slot in the game cabinet and secure with the screw at its top corner.
 - f. Plug the edge connector back onto the PCB. DON'T FORCE IT. The connector is keyed so it will only go on in the proper orientation. A reversed edge connector will damage the PCB.
3. Check all major subassemblies such as the power supply, loudspeakers (which contain powerful magnets that will attract small metal items ... remove these items), and all player-operated controls and switches. Check that the video monitors are securely mounted; tighten the hex-nuts below the video shelf as necessary.

WARNING

To avoid possible unpleasant electrical shock, do not contact internal parts of the video monitors with the hands or metal objects held in the hands. Check the monitor external mounting hardware only.

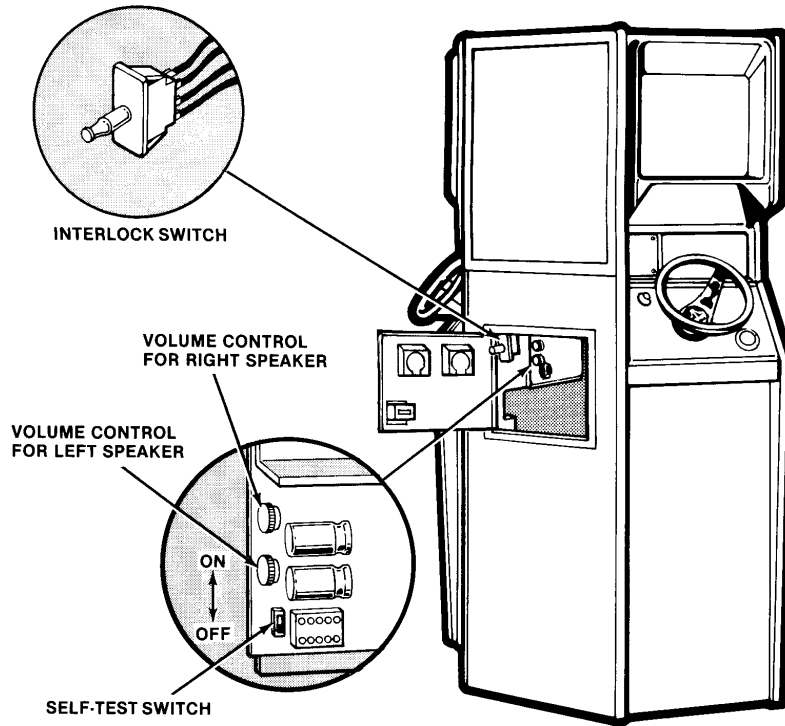

Figure 1-4 Volume Control, Self-Test Switch and Coin Door Interlock Locations

d. interlock and power on/off switch

To minimize the hazard of electrical shock while you are working on the inside of the game cabinet, two interlock switches have been installed (see Figure 1-2 and 1-4). One is located behind the rear access door and one is behind the coin door. These switches remove all the AC line power from the game circuitry when a door is opened.

Check for proper operation of the interlock switches by performing the following steps:

1. Unlock and open the rear access door and the coin door.
2. Plug the AC line power cord into an AC outlet.
3. Set the power On/Off switch to *on* position (see Figure 1-2).
4. Close the rear access and coin doors. Within approximately 30 seconds after closing the last door, the TV monitor should display a picture (the game lighting should light immediately).
5. Slowly open either door. The TV monitor picture should disappear and the game lighting should go off when either door is opened to approximately 2.5 cm. (1 inch). Repeat this step with the other door.
6. If the results of step 5 are satisfactory, the interlock switches are operating properly. If the TV monitor and game lighting don't go off as described, check to see if the corresponding interlock switch is broken from its mounting or stuck in the *on* position.
7. Close and lock the rear access door.

Table 1-2 Self-Test Procedure

INSTRUCTIONS	RESULT IF TEST PASSED	RESULT IF TEST FAILED
<p>RAM TEST: Unlock and open coin door. Interlock switch will turn power off. Throw self-test switch on Audio PCB to UP position. Pull interlock switch plunger <i>out</i>.</p>	<p>Both monitors read "RAM OK".</p> <p>Self-Test automatically advances to next test.</p>	<p>See Note Below This Table</p>
<p>ROM TEST: Automatically entered when RAM test is completed.</p>	<p>Both monitors read "ROM OK". In the case of games intended for English or German language use ONLY, the display may read "ROM A" or "ROM B". Ignore this message.</p> <p>Self-Test advances automatically to next test.</p>	<p>Both screens display "ROM" followed by one or more letters that identify faulty ROM chips or circuitry. See Table 1-4 for bad ROM (or circuitry) isolation.</p>
<p>OPTION SWITCH SETTINGS: Option switch settings are displayed at the conclusion of the ROM test.</p> <p>(See Table 1-5 for description of option switch functions, positions, etc.)</p>	<p>A row of 8 digits displays the positions of operator option switches, with switch 1 on left, 8 on the right. The digit "1" means <i>on</i>, while "0" means <i>off</i>.</p>	
<p>PLAYER CONTROLS CHECK: Each control will be identified by a word on the monitor. Move or operate each control in turn, watching the display <i>above that control</i>.</p>	<p>As the control is moved or pressed, a white square will flash just under the word that identifies that control. A "crashing" sound should also be heard from that side's speaker.</p>	<p>No flashing square or "crashing" sound.</p>

NOTES ON THE RAM TEST

Failure of a RAM chip or associated circuitry may cause erroneous monitor displays. Therefore, "pinging" sound effects and the flashing of the start LED at the *LEFT* player position are used to allow you to isolate the failed RAM circuit(s). If, during the RAM portion of self-test, you observe anything other than the RAM OK message, listen carefully and watch the *LEFT* player position start LED. The pinging sound indicates a good bit, and an LED flash indicates a bad one, so by counting the number of pings *and* flashes, the faulty RAM circuit(s) can be identified (see example below). Consult Table 1-3 for faulty RAM isolation.

In the case of more than one failed RAM circuit, the test may continue after the first flash. In this event, count the flash as if it were a ping, remembering its position in the count. (If necessary, repeat the test until you have verified the pattern of pings and flashes). Then look up the position(s) of the flash(es) in Table 1-3. Here's an example:

PING, FLASH, PING, PING, FLASH, PING, PING, FLASH
 1 2 3 4 5 6 7 8

Looking up the positions of the flashes (2, 5, and 8) in the Table tells us that we should look for trouble in or around RAM chips J3, M3, and F3. Since the test stops after the last bad bit causes a flash, there may not always be a total of eight pings/flashes.

If you lose count of the pings and flashes, restart the test. Remember to *always* begin the test by setting one of the interlock switches to its OFF position and then switching it ON to begin the test.

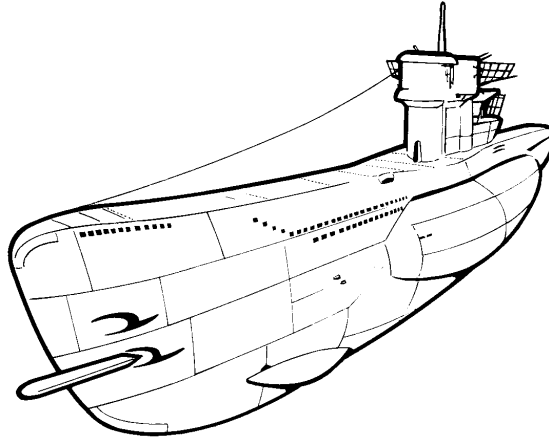

e. self-test procedure

This game will test itself and provide data to demonstrate that the game's circuitry and controls are operating properly. The data is provided on the TV monitor and the game speakers: no additional equipment is required. To start the test, unlock and open the coin door, pull out the plunger on the interlock switch (defeats the interlock switch), and slide the self-test switch to the *on* position as indicated in Figure 1-4. See Table 1-2 for instructions on operating the game's Self-Test. We suggest that you run the Self-Test each time the coin box is emptied.

f. volume adjustment

If the volume is incorrect for your location, open the coin door, pull out the interlock switch, and adjust the volume

control as indicated in Figure 1-4. Please be aware that the sonar ping sound during the attract mode may be eliminated by setting one of the option switches (see Table 1-3 of this chapter).

g. operator options

The operator options offer maximum player appeal for your game location(s). These options are listed in Table 1-5. They are preset for a certain game set-up during production of the game. To determine how the switches have been set for your game, compare the information from the self-test mode with the information in table 1-5.

To change the toggle positions of the switch assembly, you need not remove the PCB. The switch is easily accessible when the PCB is left mounted in place.

Table 1-3 Identification of Faulty RAM Chips

Count from Table 1-2	Troubleshoot this RAM:	Count from Table 1-2	Troubleshoot this RAM:
1	E3	5	M3
2	J3	6	L3
3	K3	7	H3
4	D3	8	F3

Table 1-4 Identification of Faulty ROM Chips

LETTER ON SCREEN	PROM -01 VERSION OF GAME	PROM -01 ALTERNATE VERSION	ROM -02 VERSION OF GAME
	Faulty ROM Chip		
A ¹	E1	E1	E1
B ¹	E2	E2	E2
E	H1	H1	P1
F	H2	H2	P1
G	H1	F1	P1
H	H2	F2	P1
I	K1	K1	P2
J	K2	K2	P2
K	K1	J1	P2
L	K2	J2	P2
M	M1	M1	N2
N	M2	M2	N2
O	M1 ²	L1 ²	N2
P	M2 ²	L2 ²	N2 ²

²ROM or PROM *must* be in place for self-test to run properly.

¹These chips contain ONLY French and Spanish messages. If the game is to be operated in the English or German language, there is no need to replace them. In fact, they may not even be supplied on a printed circuit board intended for use only in English- or German-speaking areas.

Table 1-5 Operator Option Settings

Option	Toggle no. of DIP Switch On Game PCB								Result
	8	7	6	5	4	3	2	1	
Game Length	On On On On Off Off Off Off	On On Off Off On On Off Off	On Off On Off On Off On Off						0:30 Minutes 1:00 Minutes * 1:30 Minutes 2:00 Minutes 2:30 Minutes 3:00 Minutes 3:30 Minutes 4:00 Minutes
Coinage/ Free Play				Off On					Free Play Coinage as determined by toggle 2.
Game Instruction Language					On On Off Off	On Off On Off			* English French Spanish German
Credit/Time							Off On		1 coin/player, fixed time. * Each coin buys time for 1 or 2 players (as set by toggles 6, 7, and 8).
Sound During Attract Mode								Off On	No sonar "ping" sound during attract mode. * "Ping" sound activated during attract mode.

* Denotes Atari factory switch settings

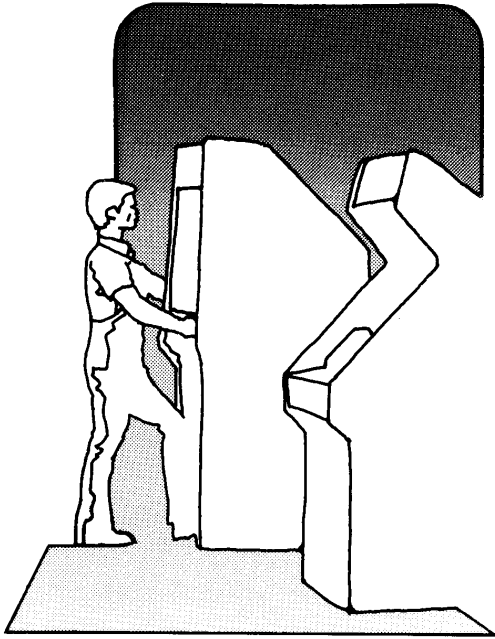

game play

a. introduction

Subs™ is a one- or two-player game that provides a realistic simulation of submarine-vs.-submarine torpedo warfare. Like most Atari video games, it uses different modes of operation, and these modes are described in this chapter. Typical attract and ready-to-play mode screen displays are shown in Figure 2-1.

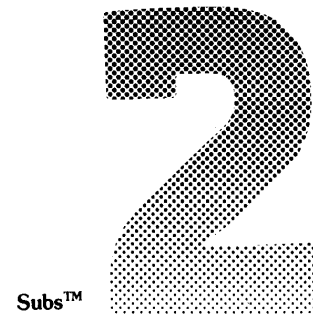

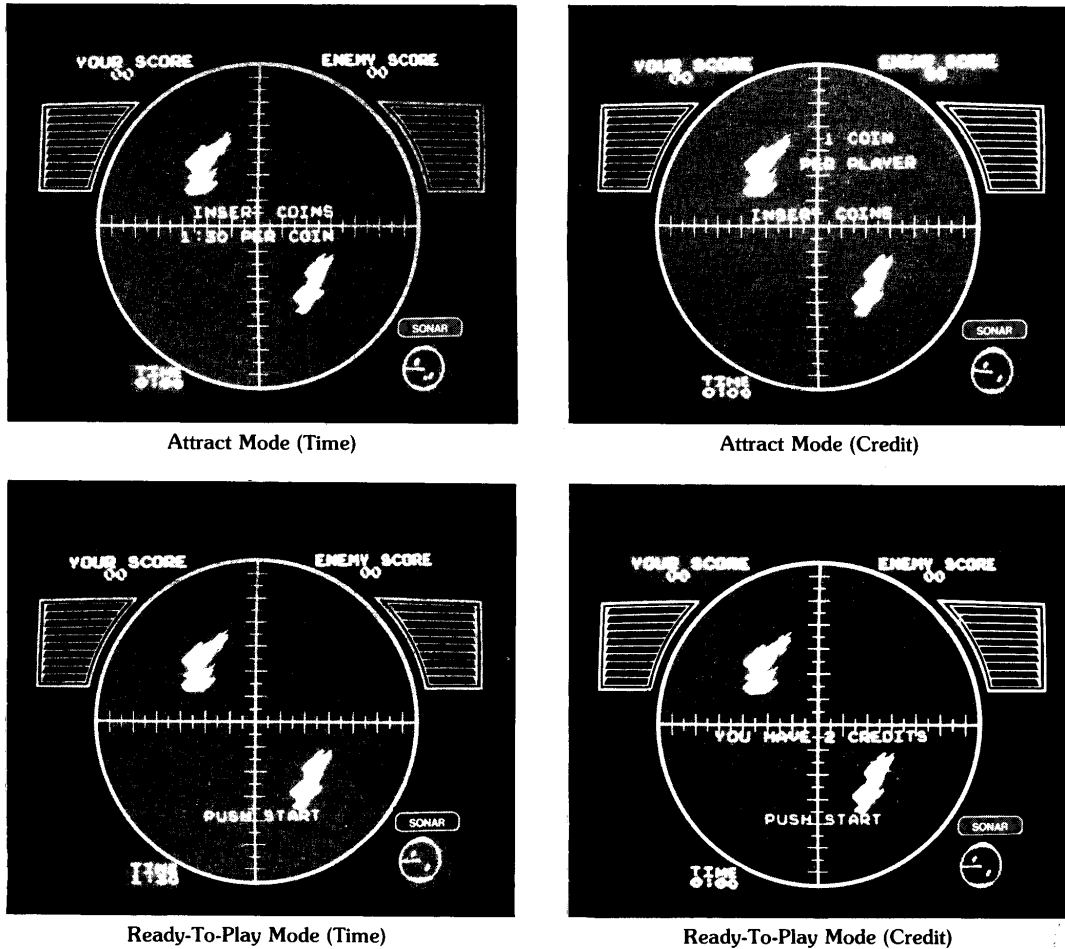

Figure 2-1 Attract and Ready-To-Play Modes

b. attract mode

When power is applied by plugging in the game and turning on the main power switch, when ending a game, or when switching out of self-test mode, Subs automatically enters the attract mode. In this mode, the game simulates a submarine battle in progress. The sonar “pinging” sound may be switched on or off by the operator, to create a silent attract mode; there are no other sound effects in this mode. Messages are displayed on the screen inviting prospective players to insert coins and play the game. Player controls are freely movable, but have no effect on the display.

c. ready-to-play mode

Subs enters this mode whenever coins are deposited. Only one coinage setting exists—one game costs one coin. The attract mode messages remain on the screens, but “PUSH START” is added, telling the player(s) that the game is ready to play. See Figure 2-1.

d. play mode

When the start button is depressed by either player, the entire display is placed in a “freeze” (no motion) for approx-

imately five seconds (or until the second start button has been pressed), and then the game begins. Since the players cannot see the position of the enemy submarine on their monitors, "clues" are provided to tell them where the enemy is. There is a "sonar" display, which gives an approximate location of the enemy. If one player runs his submarine into an island, or hits the edge of the screen, his position is displayed to the enemy. All torpedos are displayed on both screens. Using these clues, the object of the game is to maneuver one's submarine into position to launch torpedos in the direction of the enemy. Launching is accomplished by pressing the large TORPEDO FIRE button. A maximum of two torpedos per submarine may be in the "water" at any given time, and the computer prevents any more from being fired until one of the previously launched torpedos explodes. The TORPEDO FIRE button must be pressed for each torpedo, and cannot merely be held down for continuous firing.

In the credit mode (see Table 1-5), any player can deposit additional coins during the current game for future credits. This mode will then start each game fresh by resetting the

game timer at however many minutes you have set Subs for, such as 1½ minutes. The player simply has to press the start button to begin a new game.

In the time mode, either player can deposit additional coins any time during a game. This immediately adds time to the timer displays in the amount preset by the operator using the game length switches. When only 15 seconds are left in a game, the displayed timers begin flashing to warn the player(s) that the end of the game is approaching. At time zero, the game ends.

When any game ends, the screen again "freezes" for a few seconds; then the game re-enters the attract mode. The score of the last game completed remains on both monitors.

When only one player is participating, the computer-controlled submarine becomes "tougher" as the player runs up his/her score against it. This makes the game more challenging. Subs does not award free play or any other award for achieving a particular score or performance.

maintenance and adjustments

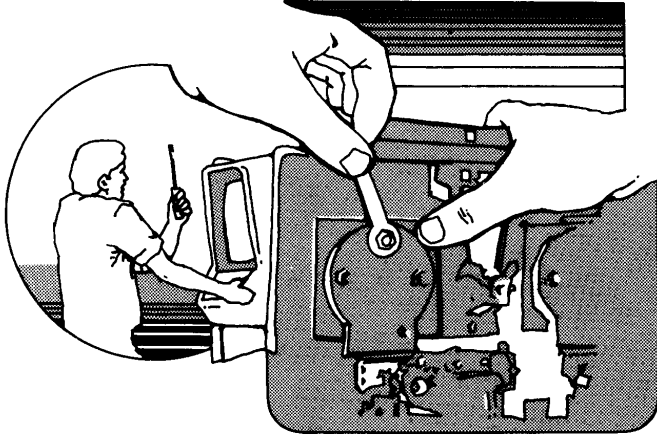

Due to its solid-state electronic circuitry, this Atari unit should require very little maintenance and only occasional adjustment. Information given in this chapter and elsewhere in this manual is intended to cover most servicing situations that may be encountered at the game site.

a. cleaning

The exteriors of game cabinets and plastic panels may be cleaned with any non-abrasive household cleaner. If desired, special coin-machine cleaners that leave no residue can be obtained from your distributor. Do *NOT* dry-wipe the acrylic plastic display cover panels because any dust can scratch the surface and result in a "foggy" appearance that will severely detract from the appeal of the game.

b. fuse replacement

Fuse location and value are shown in Figure 3-1. For continued protection of your game, as well as for the safety of the player, fuses must be replaced *only* with identically rated ones. Ratings of each fuse are shown in Figure 3-1.

c. video display monitors

1. Adjustment

The two display monitors supplied in your Subs game, like a home TV set, occasionally require adjustment of the brightness, contrast, horizontal hold, and vertical hold con-

trols. These are located at the back of the monitor chassis. Proceed with these adjustments just as you would with any TV set, but check carefully as you go to ensure that both sets display pictures that are as nearly identical as possible. For further information, see the monitor manufacturer's manual on the particular units (either TEC Videoelectronics or Zenith) that were supplied in your game.

2. Removal

The method of removal of one of the monitors is shown in Figure 3-2. Note that you first remove the screen cover/front bezel assembly. Then you can remove the TV chassis with its molded graphics overlay through the front of the game. Although shown as a separate part in the figure, the screen cover may be left attached and removed with the bezel.

WARNING

Hazard of painful and startling electric shock. Always disconnect TV monitors from electrical circuits before touching them. Avoid contact with any parts except the metal chassis. Especially avoid contacting the picture tube or any transformer.

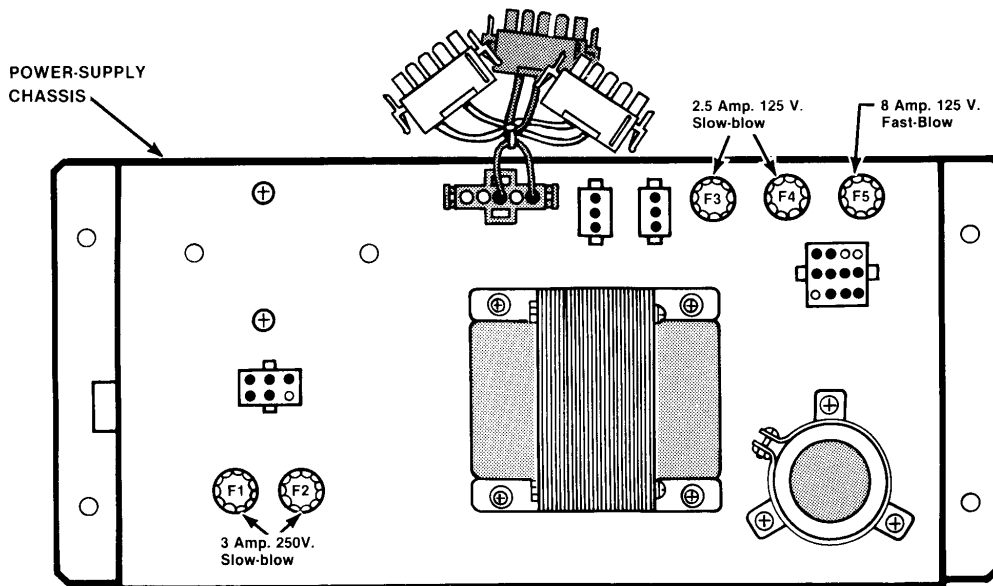

Figure 3-1 Fuse Locations

d. player control panel

See Figure 3-3 and follow these instructions to gain access to the inside of the player control panel. The LED start switch, the electronic and mechanical parts of the steering mechanism, and the TORPEDO FIRE button may all be accessed by first hinging the control panel forward and down as follows:

- Remove the four hex nuts from the bolts that secure the player control panel in place.
- Hinge the top of the panel forward and down, away from the cabinet.

e. player control removal

1. Start Button

As shown in Figure 3-3, the player start button may be removed by unscrewing its securing nut from the front of the panel and pulling out the switch. Be sure that the wires are reconnected to the correct terminals when a switch is reinstalled.

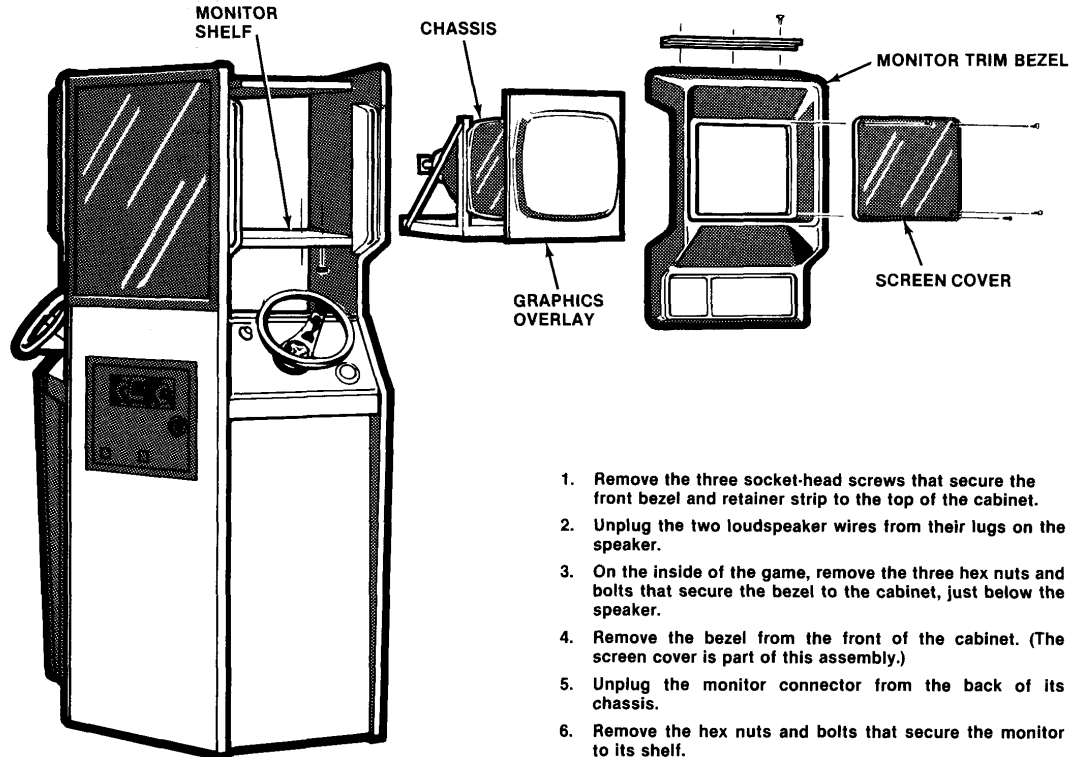

1. Remove the three socket-head screws that secure the front bezel and retainer strip to the top of the cabinet.
2. Unplug the two loudspeaker wires from their lugs on the speaker.
3. On the inside of the game, remove the three hex nuts and bolts that secure the bezel to the cabinet, just below the speaker.
4. Remove the bezel from the front of the cabinet. (The screen cover is part of this assembly.)
5. Unplug the monitor connector from the back of its chassis.
6. Remove the hex nuts and bolts that secure the monitor to its shelf.
7. Pull the monitor out through the front of the game cabinet.
8. Reverse the procedure to reinstall the monitor.

Figure 3-2 Monitor Removal

2. Steering Assembly

As shown in Figure 3-3, the steering wheel and shaft can be removed as a unit by holding the wheel securely and removing the 7/16" locking-type nut from the end of the steering shaft. Remove the black plastic light-interrupter gear from the shaft, and pull the wheel and shaft out from the front of the game. Reverse the process to reinstall. The PCB assembly that signals steering wheel motion to the game's electronics can be removed by first unplugging the white plastic connector from the board, and then removing the

cross-recessed screws that secure the board in place. Be careful not to bend the small printed circuit board!

3. TORPEDO FIRE Switch

Remove the wires by unplugging them from the switch lugs. Refer to Figure 3-3, and unscrew the four cross-recessed screws that secure the switch mounting plate to the rear of the control panel. Now squeeze the switch's retainer clips and push the switch through the mounting plate. Reverse the procedure to mount the switch.

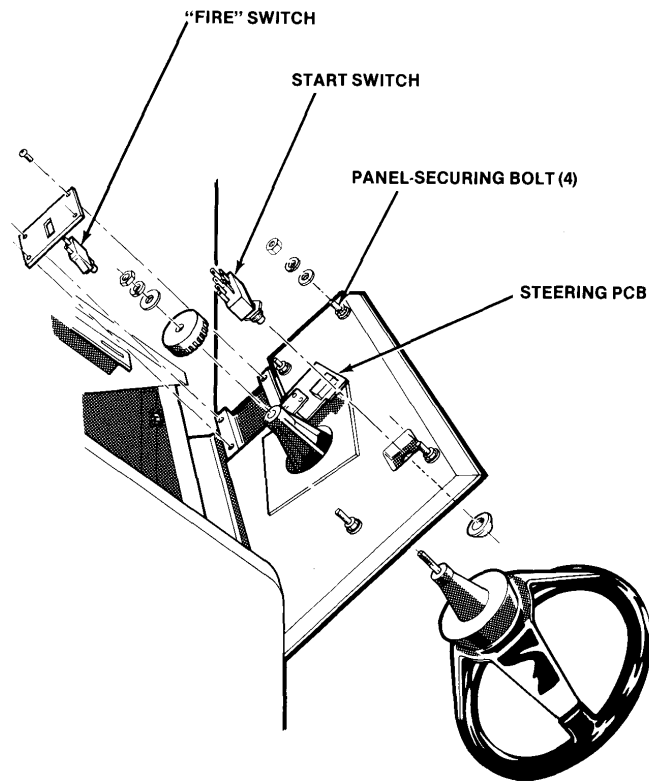

Figure 3-3 Inside of Player Control Panel

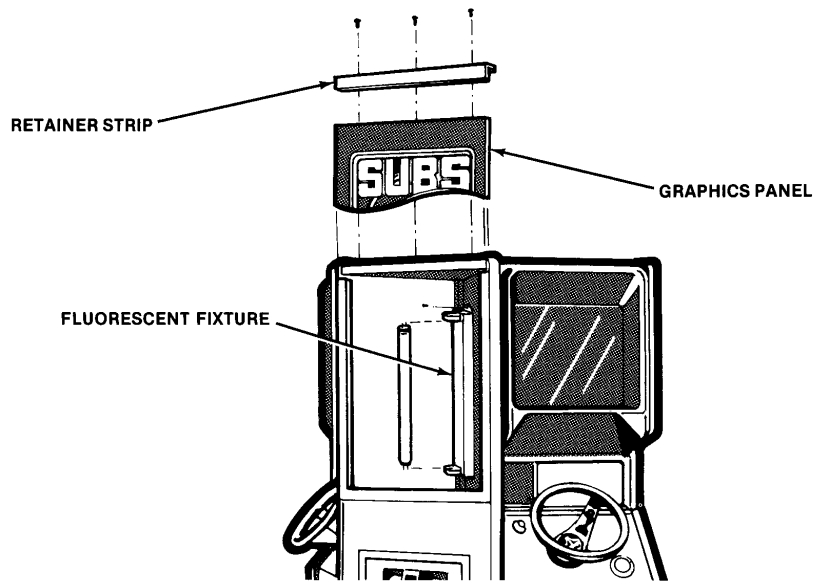

Figure 3-4 Fluorescent Tube Replacement

f. loudspeakers

One loudspeaker is supplied at each player position. If replacement is ever needed, remove the two wires attached to the lugs. Then remove the screws that secure the speaker to the inside of the bezel. Speaker location is shown in Figure 1-2. Remove the old speaker and screw a new one in place. Reconnect the two wires to the speaker lugs.

g. front panel fluorescent lamp

See Figure 3-4. To change a fluorescent tube, unscrew the top retainer screws, and remove the retainer strip from its location above the graphics panel. Slide the graphics panel directly upward and out of its grooves, exposing the fluorescent tube and its fixture. Now replace the tube as you would any household-type fluorescent lamp.

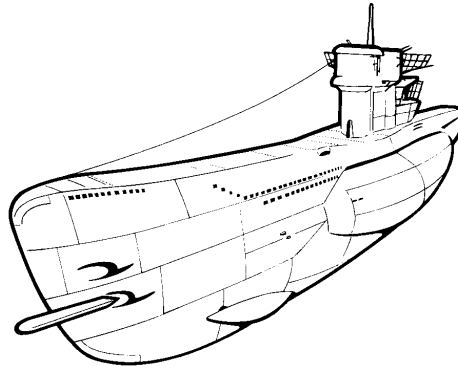

details of electronic operation

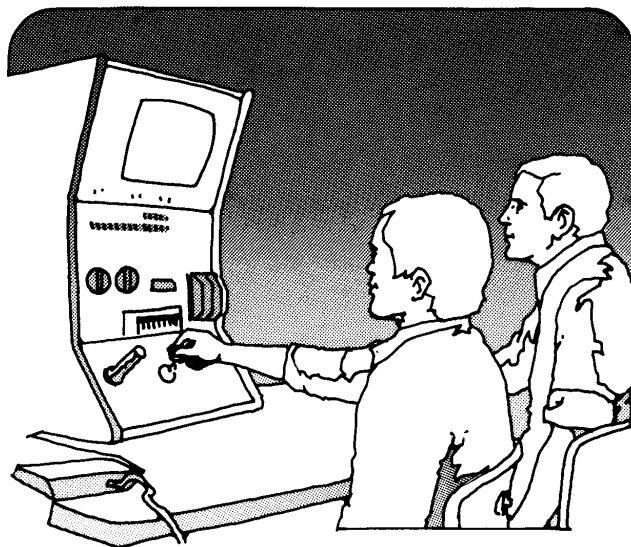

The following information provides a detailed description of the game PCB. With this information we provide block diagrams of many of the circuits. In the block diagrams we have, for the most part, used the same blocks in which we divided the schematic diagrams. We hope that this will aid you in identifying the actual functions of the circuitry.

4
Subs™

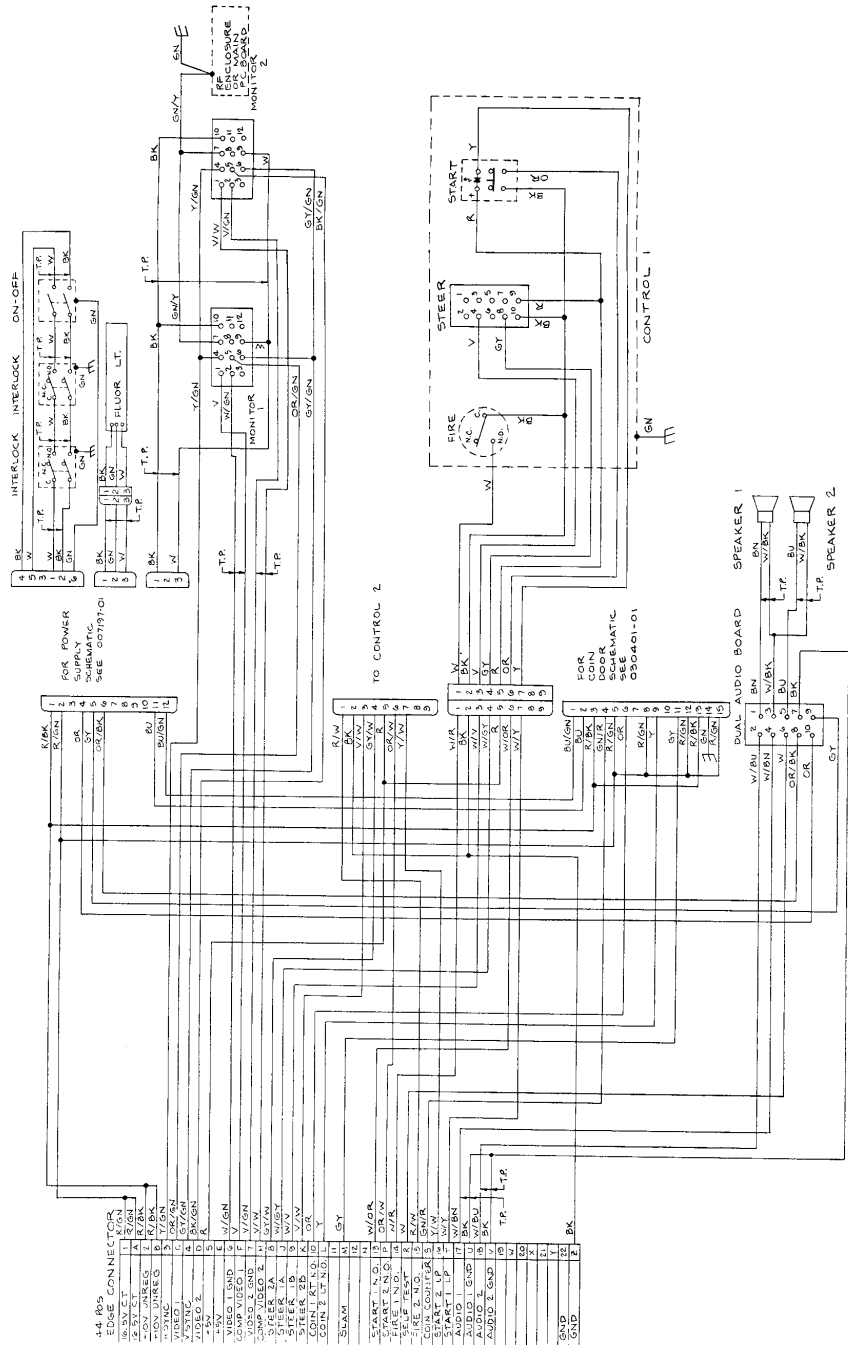

Figure 4-1 Game Power Distribution and Wiring Diagram
034233-01 A

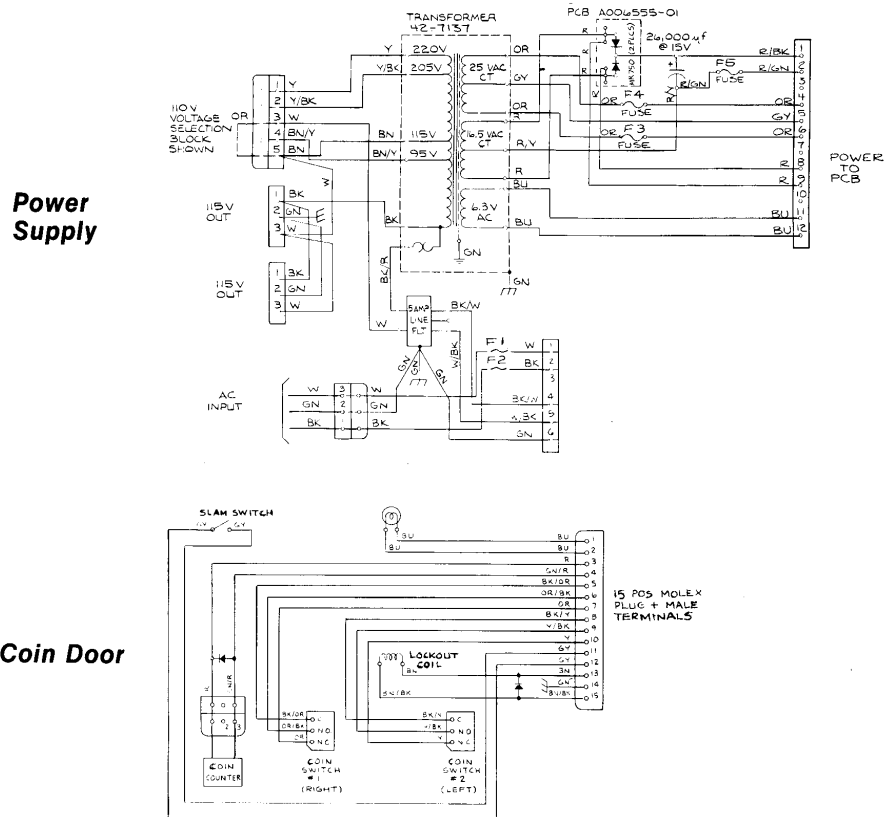

Figure 4-1 (Continued) Game Power Distribution and Wiring Diagram
007197-01 C / 030401-01 B

a. game pcb power distribution

See Figure 4-1 for information dealing with the wiring of the game, the power supply schematic and coin door schematic. See Figure 4-2 for power distribution information on the game PCB.

The game PCB receives unregulated +10 VDC from the game power supply and develops a +5 VDC regulated voltage at the output of voltage regulator LM323. The regulated voltage is used for all logic V_{cc} on the game PCB and optical sensing on the steering PCB, excluding the game PCB's audio amplifier. The audio amplifier's $V+$ is derived from the game power supply's filtered +18 VDC.

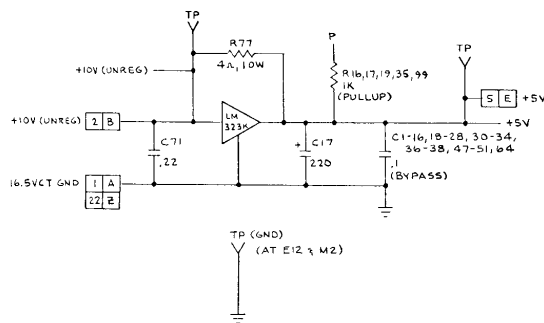

Figure 4-2 Game PCB Power Distribution

b. sync circuitry

(See Figure 4-3)

6 MHz and horizontal synchronization signals are the direct output of counters P6, P7 and P8. These signals are the result of counting the pulses from crystal Y1. Further shaping of horizontal sync pulses through flip-flop M9 develops HSYNC.

Vertical synchronization signals are the direct output of counters N6 and N7. These signals are the result of counting

HSYNC pulses. Vertical synchronization components are developed by sync PROM N8 and clocked through latch N9 by HSYNC.

Both horizontal and vertical sync signals are gated, then clocked, through flip-flops M6 thru M8 to produce space on each monitor for the sonar display. Signal $\overline{\text{SNRWND0}}$ signals the playfield ROMs that it is time to output sonar display information. Signal $\overline{\text{SNRWND01}}$ inhibits the playfield ROM output data from the left TV monitor. Signal $\overline{\text{SNRWND02}}$ inhibits the playfield ROM output data from the right TV monitor.

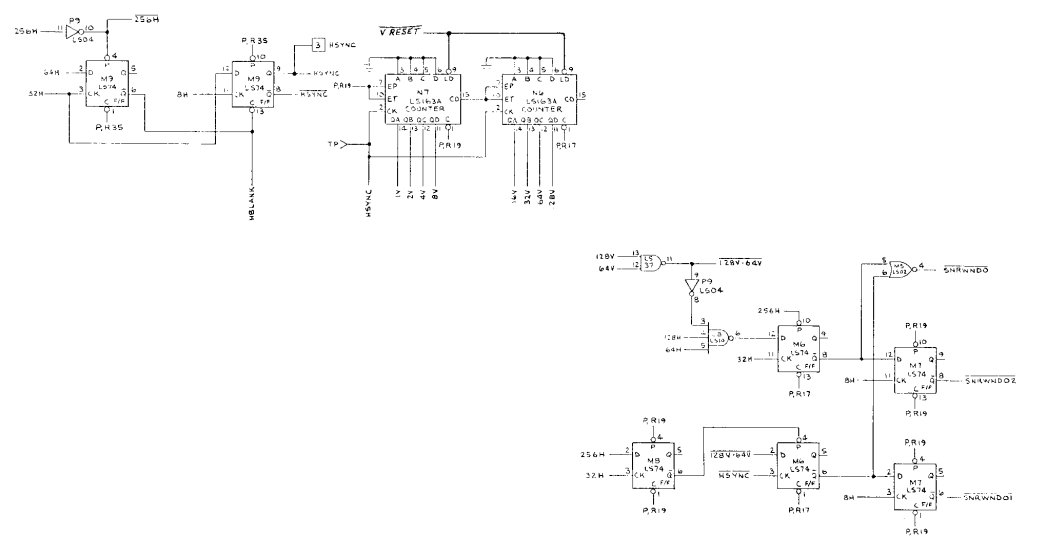
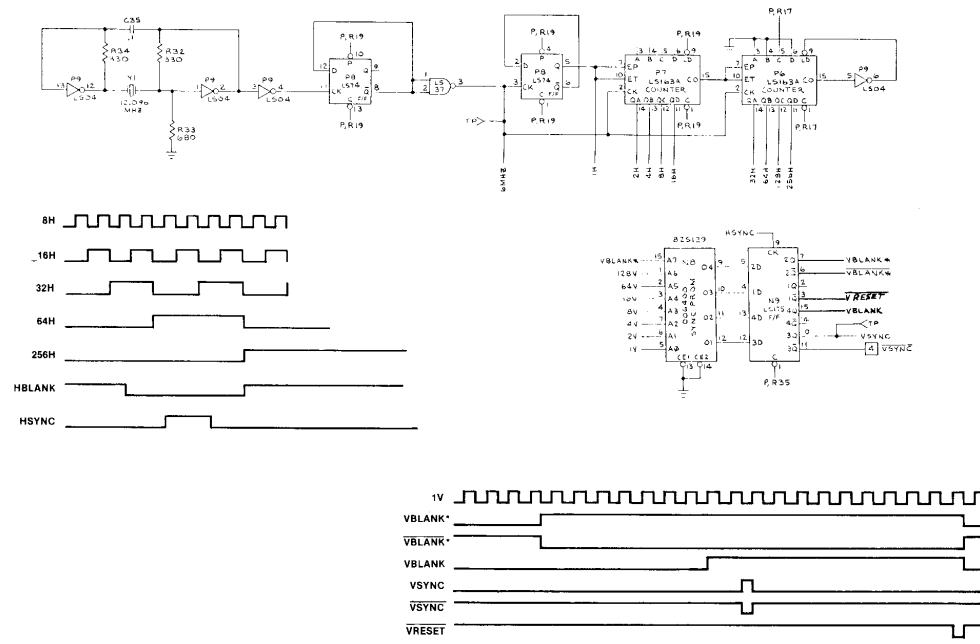

Figure 4-3 Sync Circuitry

C. microprocessor circuitry

MPU (Microprocessor) (See Figure 4-4)

The MPU, at location C2/3, controls the game play. This device outputs address, reads data instructions, stores data in the RAM (random-access memory), reads previously stored data from the RAM, reads switches and steering information, and writes to playfield video circuitry.

$\Phi 0$ (phase 0), NMI, and $\overline{\text{RESET}}$ are the controlling inputs to the MPU which determine its timing, "interrupt", and initialization status.

The MPU receives 4H from the sync circuitry, conditions the signal and outputs two non-overlapping clock signals; $\Phi 1$ and $\Phi 2$. These signals are critical to the synchronization of the MPU support circuitry.

The NMI (non-maskable interrupt) pulse input occurs four times during each frame of video (32V). When the NMI pulse is received, the MPU completes its present transaction, then outputs addresses for reading coin switch and steering input information.

During the Self-Test mode, signal $\overline{\text{TEST}}$ goes low, inhibiting the NMI input.

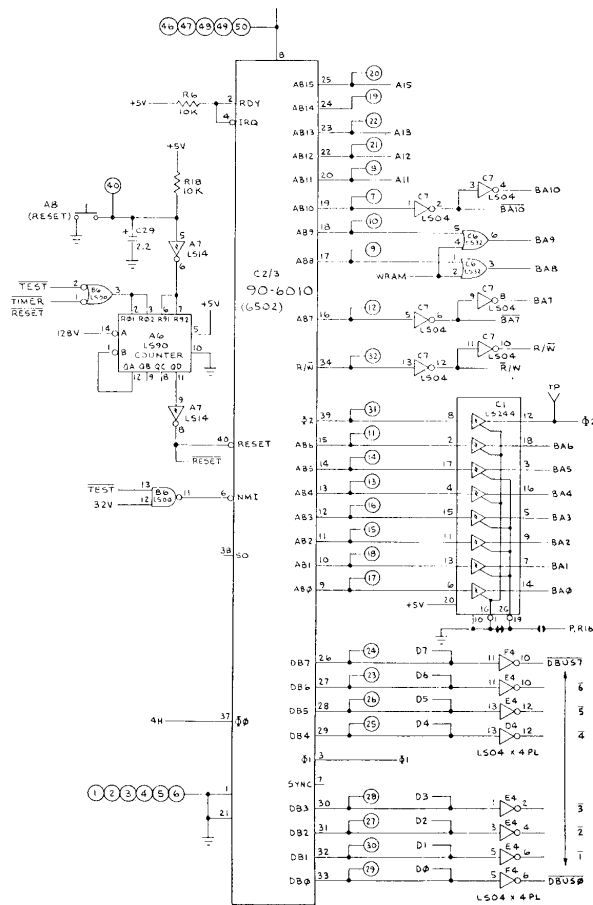

Figure 4-4 Microprocessor

The $\overline{\text{RESET}}$ signal forces the MPU to initialize the system when power is initially applied to the game, if switch A8 (RESET) is pressed, or if a program malfunction occurs (when the MPU fails to output a $\overline{\text{TIMER RESET}}$ address before counter A6 reaches the count of eight.)

During the Self-Test mode, signal $\overline{\text{TEST}}$ goes low, disabling counter A6.

Address Decoder (See Figure 4-5)

The Address Decoder enables certain sections of game circuitry (i.e., RAM, program memory, audio, etc.) when addressed by the MPU. When enabled, data is transferred between game circuitry and the MPU.

Table 4-1 is the memory map for this game. The memory map shows which section of the game circuitry is enabled by a particular address. Note that the address is given in both hexadecimal and binary numbers. In the binary column, an X indicates that it makes no difference whether that address line is high or low. The address lines necessary to select a given output of the address decoder are indicated with ones and zeros. The actual address lines that are used to address the selected game circuitry are indicated by As (plural of A). The R/W column shows that when $\overline{\text{WRITE}}$ (designated by W) is low, the MPU is writing to the selected circuitry. When $\overline{\text{READ}}$ is low, the MPU is reading the selected circuitry. If the column indicates a R/W, the MPU both reads and writes to the selected circuitry. The data column shows the data lines (each used data line is indicated by a D) used in the read or write operation. The function column defines the purpose of the read or write operation.

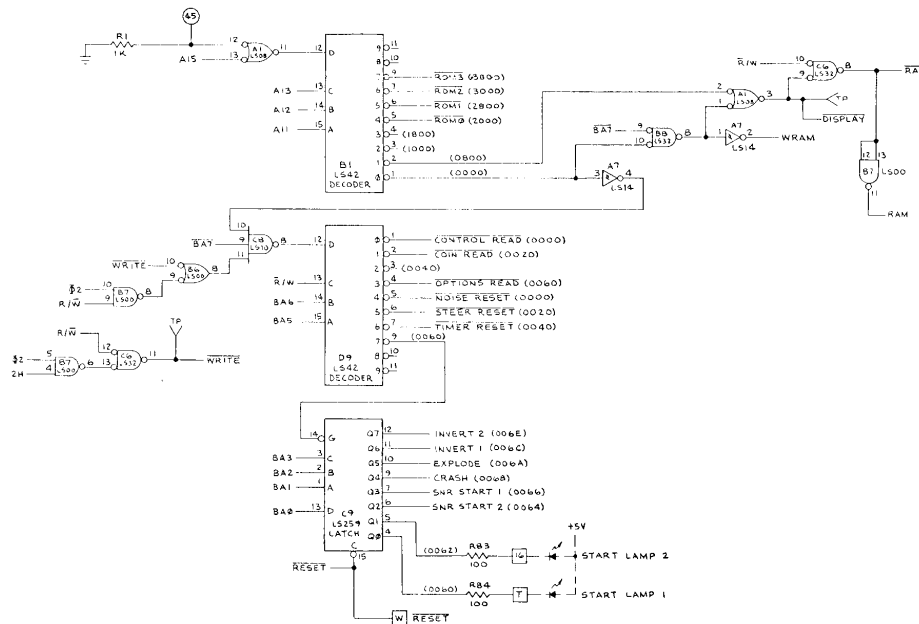

Figure 4-5 Address Decoder

Table 4-1 Memory Map

HEXADECIIMAL	ADDRESS																R/W	DATA								FUNCTION
	A15	A14	A13	A12	A11	A10	A9	A8	A7	A6	A5	A4	A3	A2	A1	A0		D7	D6	D5	D4	D3	D2	D1	D0	
0000	0	X	0	0	0	X	X	X	0	0	0	X	X	0	0	0	R	D	X	X	X	X	X	X	X	DIAG STEP *
0001	0	X	0	0	0	X	X	X	0	0	0	X	X	0	0	1	R	D	X	X	X	X	X	X	X	DIAG HOLD *
0002	0	X	0	0	0	X	X	X	0	0	0	X	X	0	1	0	R	D	X	X	X	X	X	X	X	SLAM *
0003	0	X	0	0	0	X	X	X	0	0	0	X	X	0	1	1	R	D	X	X	X	X	X	X	X	SPARE *
0004	0	X	0	0	0	X	X	X	0	0	0	X	X	1	0	0	R	D	X	X	X	X	X	X	X	STEER DIR 1
0005	0	X	0	0	0	X	X	X	0	0	0	X	X	1	0	1	R	D	X	X	X	X	X	X	X	STEER FLAG 1
0006	0	X	0	0	0	X	X	X	0	0	0	X	X	1	1	0	R	D	X	X	X	X	X	X	X	STEER DIR 2
0007	0	X	0	0	0	X	X	X	0	0	0	X	X	1	1	1	R	D	X	X	X	X	X	X	X	STEER FLAG 2
0020	0	X	0	0	0	X	X	X	0	0	1	X	X	0	0	0	R	D	X	X	X	X	X	X	X	COIN 2
0021	0	X	0	0	0	X	X	X	0	0	1	X	X	0	0	1	R	D	X	X	X	X	X	X	X	START 1 *
0022	0	X	0	0	0	X	X	X	0	0	1	X	X	0	1	0	R	D	X	X	X	X	X	X	X	COIN 1
0023	0	X	0	0	0	X	X	X	0	0	1	X	X	0	1	1	R	D	X	X	X	X	X	X	X	START 2 *
0024	0	X	0	0	0	X	X	X	0	0	1	X	X	1	0	0	R	D	X	X	X	X	X	X	X	VBLANK *
0025	0	X	0	0	0	X	X	X	0	0	1	X	X	1	0	1	R	D	X	X	X	X	X	X	X	FIRE 1 *
0026	0	X	0	0	0	X	X	X	0	0	1	X	X	1	1	0	R	D	X	X	X	X	X	X	X	TEST *
0027	0	X	0	0	0	X	X	X	0	0	1	X	X	1	1	1	R	D	X	X	X	X	X	X	X	FIRE 2 *
0060	0	X	0	0	0	X	X	X	0	1	1	X	X	X	0	0	R	X	X	X	X	X	X	D	D	OPTION SWITCH
0061	0	X	0	0	0	X	X	X	0	1	1	X	X	X	0	1	R	X	X	X	X	X	X	D	D	OPTION SWITCH
0062	0	X	0	0	0	X	X	X	0	1	1	X	X	X	1	0	R	X	X	X	X	X	X	D	D	OPTION SWITCH
0063	0	X	0	0	0	X	X	X	0	1	1	X	X	X	1	1	R	X	X	X	X	X	X	D	D	OPTION SWITCH
0000	0	X	0	0	0	X	X	X	0	0	0	X	X	X	X	X	W	X	X	X	X	X	X	X	X	NOISE RESET
0020	0	X	0	0	0	X	X	X	0	0	1	X	X	X	X	X	W	X	X	X	X	X	X	X	X	STEER RESET
0040	0	X	0	0	0	X	X	X	0	1	0	X	X	X	X	X	W	X	X	X	X	X	X	X	X	TIMER RESET
0060-0061	0	X	0	0	0	X	X	X	0	1	1	X	0	0	0	D	W	X	X	X	X	X	X	X	X	START LAMP 1 ON/OFF
0062-0063	0	X	0	0	0	X	X	X	0	1	1	X	0	0	1	D	W	X	X	X	X	X	X	X	X	START LAMP 2
0064-0065	0	X	0	0	0	X	X	X	0	1	1	X	0	1	0	D	W	X	X	X	X	X	X	X	X	SONAR START 2 OFF/ON
0066-0067	0	X	0	0	0	X	X	X	0	1	1	X	0	1	1	D	W	X	X	X	X	X	X	X	X	SONAR START 1
0068-0069	0	X	0	0	0	X	X	X	0	1	1	X	1	0	0	D	W	X	X	X	X	X	X	X	X	CRASH OFF/ON
006A-006B	0	X	0	0	0	X	X	X	0	1	1	X	1	0	1	D	W	X	X	X	X	X	X	X	X	EXPLODE
006C-006D	0	X	0	0	0	X	X	X	0	1	1	X	1	1	0	D	W	X	X	X	X	X	X	X	X	VIDEO INVERT 1 ON/OFF
006E-006F	0	X	0	0	0	X	X	X	0	1	1	X	1	1	1	D	W	X	X	X	X	X	X	X	X	VIDEO INVERT 2
0080-00FF	0	X	0	0	0	X	X	X	1	A	A	A	A	A	A	A	R/W	D	D	D	D	D	D	D	D	RAM
0090	0	X	0	0	0	X	X	X	1	0	0	1	0	0	0	0	R/W	D	D	D	D	D	D	D	D	HPOS-SUB 1
0091	0	X	0	0	0	X	X	X	1	0	0	1	0	0	0	1	R/W	D	X	X	X	X	X	X	X	SUB 1 ENABLE
0092	0	X	0	0	0	X	X	X	1	0	0	1	0	0	1	0	R/W	D	D	D	D	D	D	D	D	HPOS-SUB 2
0093	0	X	0	0	0	X	X	X	1	0	0	1	0	0	1	1	R/W	D	X	X	X	X	X	X	X	SUB 2 ENABLE
0094	0	X	0	0	0	X	X	X	1	0	0	1	0	1	0	0	R/W	D	D	D	D	D	D	D	D	HPOS-TORPEDO 1
0095	0	X	0	0	0	X	X	X	1	0	0	1	0	1	0	1	R/W	X	X	X	X	D	D	D	D	LAUNCH SOUND
0095	0	X	0	0	0	X	X	X	1	0	0	1	0	1	0	1	R/W	D	D	D	D	X	X	X	X	EXPLOSION SOUND
0096	0	X	0	0	0	X	X	X	1	0	0	1	0	1	1	0	R/W	D	D	D	D	D	D	D	D	HPOS-TORPEDO 2
0098	0	X	0	0	0	X	X	X	1	0	0	1	1	0	0	0	R/W	D	D	D	D	D	D	D	D	VPOS-SUB 1
0099	0	X	0	0	0	X	X	X	1	0	0	1	1	0	0	1	R/W	D	D	D	D	D	X	X	D	ROTATION-SUB 1
009A	0	X	0	0	0	X	X	X	1	0	0	1	1	0	1	0	R/W	D	D	D	D	D	D	D	D	VPOS-SUB 2
009B	0	X	0	0	0	X	X	X	1	0	0	1	1	0	1	1	R/W	D	D	D	D	D	D	X	D	ROTATION-SUB 2
009C	0	X	0	0	0	X	X	X	1	0	0	1	1	1	0	0	R/W	D	D	D	D	D	D	D	D	VPOS-TORPEDO 1
009D	0	X	0	0	0	X	X	X	1	0	0	1	1	1	0	1	R/W	D	D	D	D	D	X	X	D	ROTATION-TORPEDO 1
009E	0	X	0	0	0	X	X	X	1	0	0	1	1	1	1	0	R/W	D	D	D	D	D	D	D	D	VPOS-TORPEDO 2
009F	0	X	0	0	0	X	X	X	1	0	0	1	1	1	1	1	R/W	D	D	D	D	D	X	X	D	ROTATION-TORPEDO 2
0800-0B7F	0	X	0	0	1	X	A	A	A	A	A	A	A	A	A	A	R/W	D	D	D	D	D	D	D	D	SCREEN RAM
2000-27FF	0	X	1	0	0	A	A	A	A	A	A	A	A	A	A	A	R	D	D	D	D	D	D	D	D	ROM 0
2800-2FFF	0	X	1	0	1	A	A	A	A	A	A	A	A	A	A	A	R	D	D	D	D	D	D	D	D	ROM 1
3000-37FF	0	X	1	1	0	A	A	A	A	A	A	A	A	A	A	A	R	D	D	D	D	D	D	D	D	ROM 2
3800-3FFF	0	X	1	1	1	A	A	A	A	A	A	A	A	A	A	A	R	D	D	D	D	D	D	D	D	ROM 3

*LOW TRUE

The Address Decoder consists of two decoders, B1 and D9, and latch C9. Decoder B1, driven by address lines A11 thru A13, enables any one of four sections of program memory. At address location 0080 (RAM Page 0), WRAM forces address lines BA8 and BA9 high, resulting in address location 0380. The RAM is enabled with a low $\overline{\text{DISPLAY}}$ signal and data is read from the RAM when RAM goes low.

The inputs of decoder D9 are arranged so that one output is selected during a read cycle and another output is selected during a write cycle. At address location 0060, the

options switches are read during the read cycle ($\overline{\text{OPTIONS READ}}$). During the write cycle, the MPU may latch enables to the sound circuits, video inverter, or to the START LEDs, through latch C9.

Program Memory (See Figure 4-6)

Program Memory consists of ROMs (read-only memory) N2, P1 and P2 and ROMs on the -02 PCB. On the -01 PCB, program memory consists of 12 PROMs: F1, F2, H1,

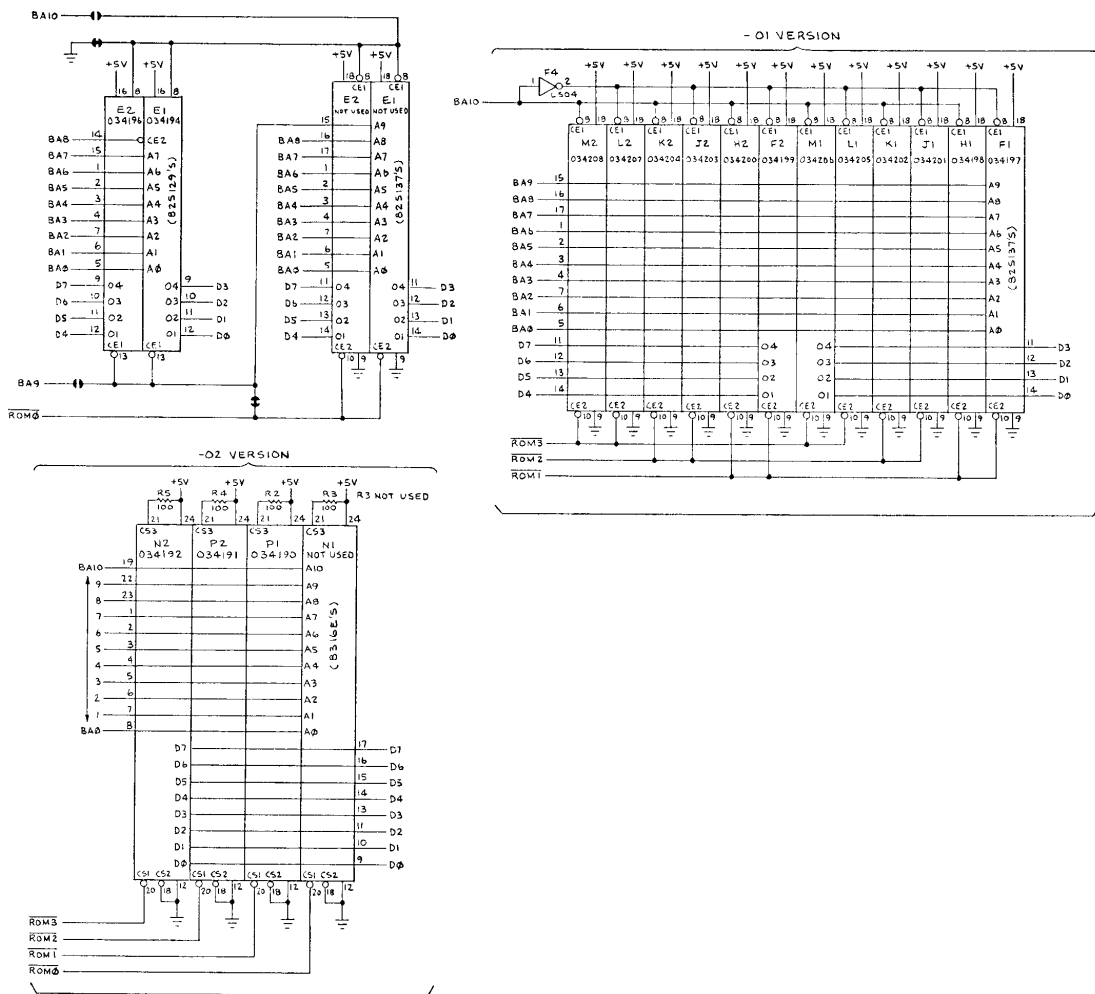

Figure 4-6 Program Memory

H2, J1, J2, K1, K2, L1, L2, M1, and M2. On both the -01 and -02 PCBs additional program space is included in PROMs E1 and E2.

When we begin the production of a new video game, we generally program our own memory (PROMs). After the first few weeks of production, we begin installing ROM memory in our games. Therefore, when you received this game you may have either twelve PROMs or four ROMs, plus PROMs E1 and E2 for program memory. In fact, it is even possible to have a combination of both ROMs and PROMs in your game. See Figure 5-5 in the Illustrated Parts Catalog of this manual for ROM/PROM equivalent and part number information.

If a PROM fails, don't order a replacement PROM before checking with our customer service people. It might be cheaper to replace that PROM with a ROM.

The program memory is a sequence of instructions which tell the MPU how to run the game play, video display and associated hardware. Each ROM or equivalent set of PROMs are individually enabled by the address decoder.

In addition to address decoder enabling, the PROM set is also enabled by BA10 from the microprocessor.

RAM (See Figure 4-7)

The function of the RAM is to act as a storage medium for the information that the MPU decides it wants to save, and then later recall, or for the playfield information to address the playfield memory. The MPU reads data from the RAM through tri-state buffer C4. The motion circuit reads stored

video information from the RAM both directly from the PRAMx data signals and the latched DMAx and DMAx signals at the outputs of latches D5 and D6.

d. switch and steering input circuitry

(See Figure 4-8)

The option switch toggles are read by the MPU on data lines D0 and D1 through data selector/multiplexer E9. When a switch toggle is open, that input is pulled up to +5 VDC; when closed that input is grounded.

The player switches and $\overline{\text{VBLANK}}$ pulse are read by the MPU on data line D7 through data selector/multiplexer E10. Excluding the coin switch inputs, an E10 input is pulled to ground when a switch is closed or when $\overline{\text{TEST}}$ (active when low) input is present. Due to inverters H11, a coin switch input to E10 is high when that switch is tripped. If either switch is tripped, the coin counter is tripped through OR gate L11 and driver transistor Q1.

The SLAM switch and steering inputs are read by the MPU on data line D7 through data selector/multiplexer F10. When the SLAM switch is closed, its F10 input is pulled from +5 VDC to ground.

Steering information is received by F10 from flip-flops H10 and J10. The relationship of the game PCB steering inputs are shown in Figure 4-8.

Signals DIAG STEP and DIAG HOLD are used only for manufacturing purposes.

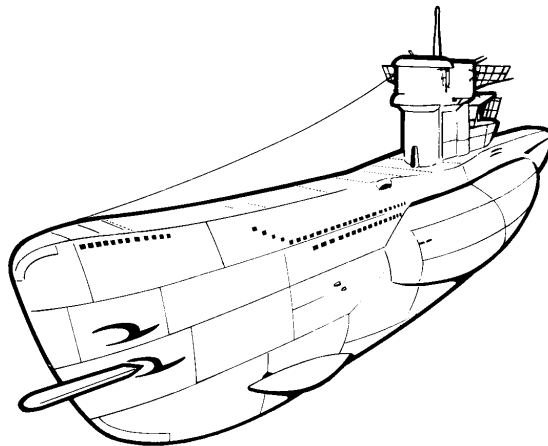

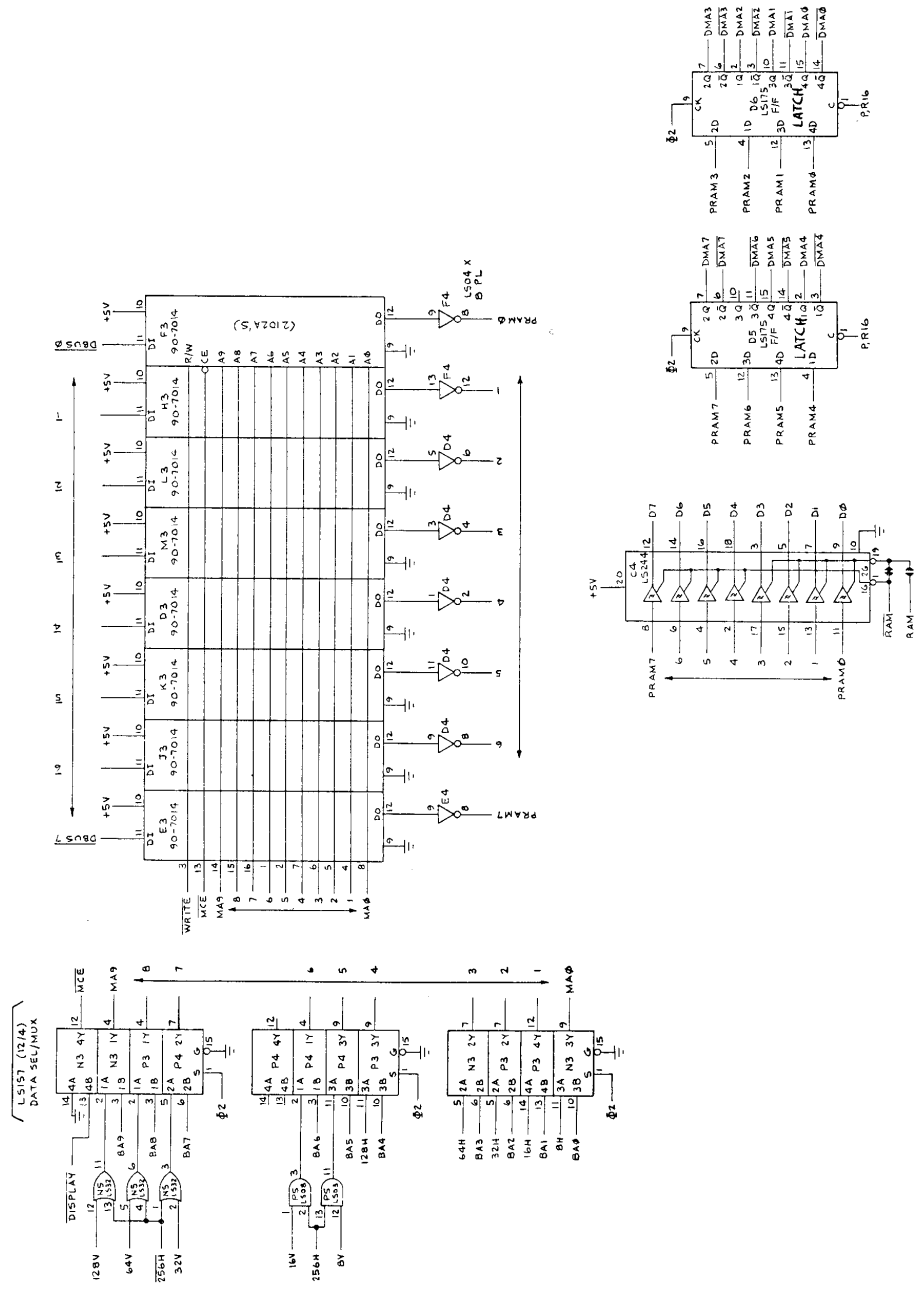

Figure 4-7 RAM

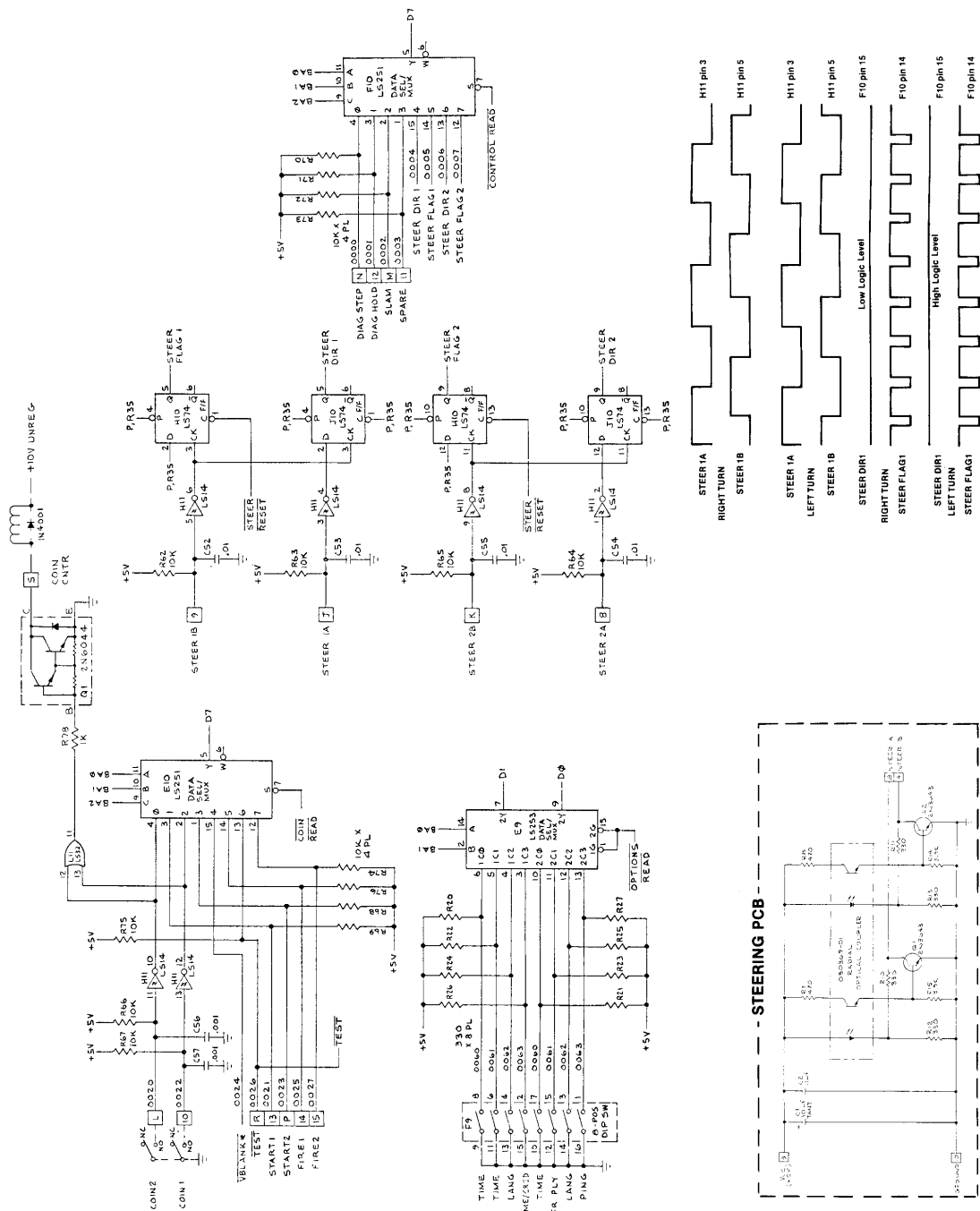

Figure 4-8 Switch and Steering Input

e. video circuitry

(See Figures 4-9 thru 4-11)

The video circuitry consists of the Playfield Circuit, Motion Circuit and Video Summing Circuit.

Playfield Circuit (See Figure 4-9)

The Playfield Circuit generates the islands and all alpha- numerics. All generated playfield signals are from playfield

memory ROM (-02 game PCB). If you have a -01 game PCB, the information is generated from playfield memory PROMs H4, J4, K4, and L4. The playfield memory receives its address from three sources: from the MPU circuitry's RAM (DMA0 thru DMA5), from vertical sync 1V thru 4V, and from gates M5.

The address input from the MPU circuitry's RAM defines the playfield picture. As discussed in the MPU circuitry's RAM section of this manual, the MPU writes data into the RAM at certain RAM address locations. During the read cycle, the RAM is addressed by horizontal and vertical sync.

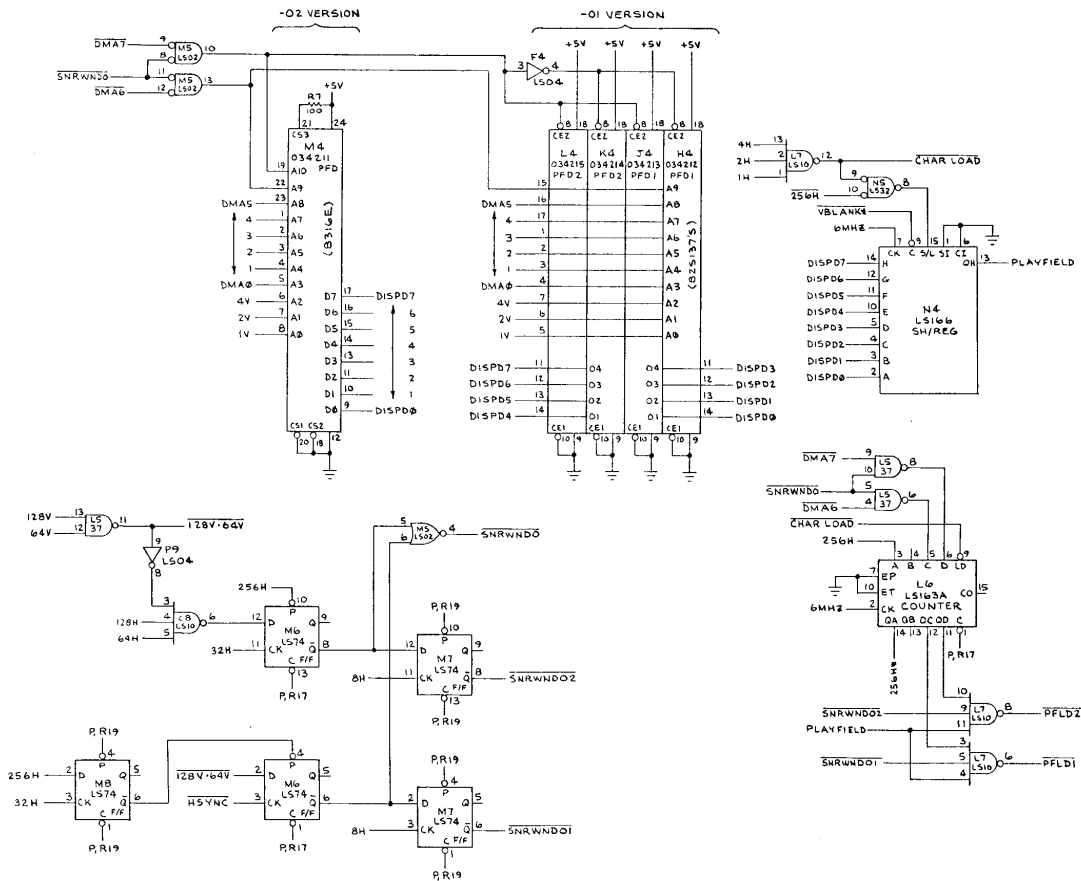

Figure 4-9 Playfield Circuit

As sync addresses the RAM, the RAM outputs data that addresses the playfield memory. This address defines a certain picture to be displayed.

Sync signals 1V, 2V, and 4V address the playfield memory to tell it which of the eight vertical lines of the picture to output.

If the playfield picture is a sonar display, sync outputs a sonar window pulse SNRWND0 that permits signals DMA6 and DMA7 to address the playfield memory through gates M5.

Display data (DISPD0 thru DISPD7) input to shift register N4 is loaded when 1H, 2H and 4H are all high, 256H is low (during scan time), and VBLANK* is high (not during vertical retrace time). When 1H, 2H, and 4H go low, N4 shifts the playfield picture data out at a 6 MHz rate.

When DMA6 is low at the input of AND gate L5, playfield picture information is enabled to output through the PFLD1 (right monitor) output of AND gate L7. Playfield information is output through PFLD2 output of AND gate L7 if DMA7 input to NAND gate L5 is low.

At the bottom of each picture frame, sync outputs a SNRWND01 signal that inhibits the PFLD1 when the sonar display is for the left TV monitor. SNRWND02 inhibits the PFLD2 output when the sonar display is for the right TV monitor.

Motion Circuitry (See Figure 4-10)

The Motion circuitry generates two submarines and their explosion pictures, and two torpedos and their explosion pictures. The right half of a submarine and its explosion pictures are from motion PROM D7. The left half is from PROM D8. The right half of a torpedo and its explosion picture is from motion PROM E7. The left half is from ROM E8.

The combination of PROM D7 and D8 contains several different pictures of a submarine and two explosion pictures. Each submarine picture is sixteen vertical lines high by fifteen horizontal bits wide and has a different rotation to provide

different directions of travel on the TV monitor. The combination of PROMs E7 and E8 contains several different pictures of a torpedo and two explosion pictures. Each torpedo is sixteen vertical lines high by fifteen horizontal bits wide and has a different rotation to provide different directions of travel on the TV monitor.

The motion PROMs receive their address from the MPU circuitry's RAM and from the outputs of comparator E6. If high, PRAM0 selects ROM set E7/E8; the torpedos. If low, PRAM0 selects PROM set D7/D8 is selected; the submarines. PRAM3 thru PRAM7 address inputs define the rotational picture to be output by the motion PROM.

Comparators E5 and E6 receive an address from the MPU circuitry's RAM that defines the line on which the picture, from the motion PROM, is to begin being displayed. When the vertical sync count is equal to the DMAx inputs to comparator E5 and E6, all outputs of E5 go high for sixteen counts of 1V. If 256H is high (during horizontal retrace), decoder K9 begins outputting load signals when further conditions are met as illustrated in Figure 4-10. The load signals permit the motion ROM data to be loaded into the video shift registers.

The output of comparator E6 tells the motion PROM which of the sixteen vertical lines of the picture is to be output by the PROM. The PROM output, VID1 thru VID15, is the actual fifteen-bit video picture for one horizontal scan line.

In review, the MPU circuitry's RAM provides data that addresses the motion ROM. This information defines the picture of the motion object and the vertical location on the TV monitor. Vertical sync tells the motion ROM and load circuit when the vertical location has been reached by the raster scan and which line of the motion object picture should be output by the motion ROM.

NOTE

Since all four motion object output circuits are identical, the following discussion relates only to SUB1.

Additional information is required to tell the motion circuitry where to place the motion object horizontally on the



4-14 Subs™

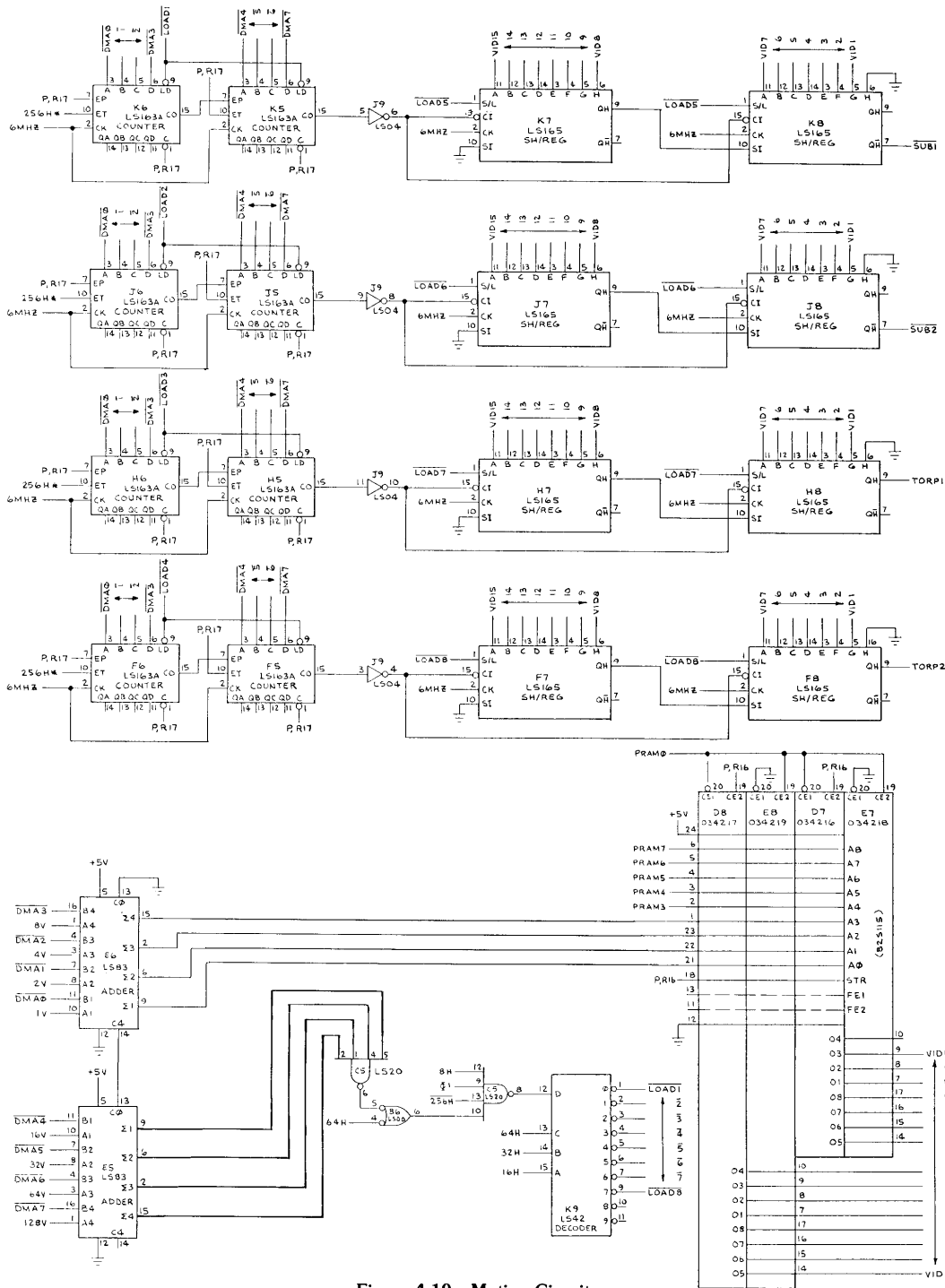
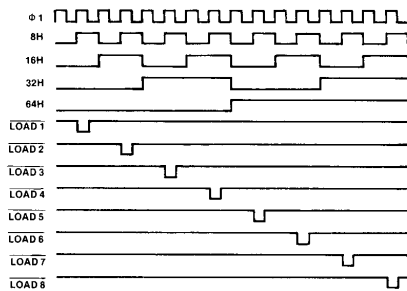

Figure 4-10 Motion Circuit

TV monitor. This is done by loading a number (from 0 to 255) into the motion counters. When $\overline{LOAD1}$ occurs, horizontal placement signals $\overline{DMA0}$ thru $\overline{DMA7}$ are loaded into counters K5 and K6. When $\overline{LOAD5}$ occurs, VID1 thru VID15 is loaded into shift registers K7 and K8. When $256H^*$ (the beginning of the horizontal scan line) goes high, the counters count at a 6 MHz rate until the count of 240 is reached. At count 240, the carry output enables the shift registers to shift the motion object video bits out, one at a time, at a 6 MHz rate. After count 256, the carry output disables the shift registers.



Video Summing Circuit (See Figure 4-11)

The video summing circuit receives the six separate video picture signals and outputs two separate TV monitor signals.

If the game contains a TEC monitor, the video input to the monitor is a composite video signal. The signal contains HSYNC, VSYNC, HBLANK, and VBLANK and the video display signal.

If the game contains a Zenith monitor, there are three separate inputs to the monitor. One is HSYNC and the other is VSYNC, from the sync circuit. The third signal is the video display signal.

The video display for each monitor contains picture information for one playfield (PFLD1 for the left monitor; PFLD2 for the right monitor), both torpedos, and one submarine (SUB1 for the left monitor; SUB2 for the right monitor.) However, if PRAM7, from the MPU circuitry's RAM, is high during the motion circuit's $\overline{LOAD1}$ signal, the SUB1 video picture is enabled for display (SUBEN1) on the right monitor. If PRAM7 is high during the $\overline{LOAD2}$ pulse, the SUB2 video picture is enabled for display (SUBEN2) on the left monitor.

If the MPU circuitry's address decoder outputs a high INVERT (1 for right monitor; 2 for left monitor) signal, the video output signal is negated. This results in a negative display on the monitor when that sub is hit by a torpedo.

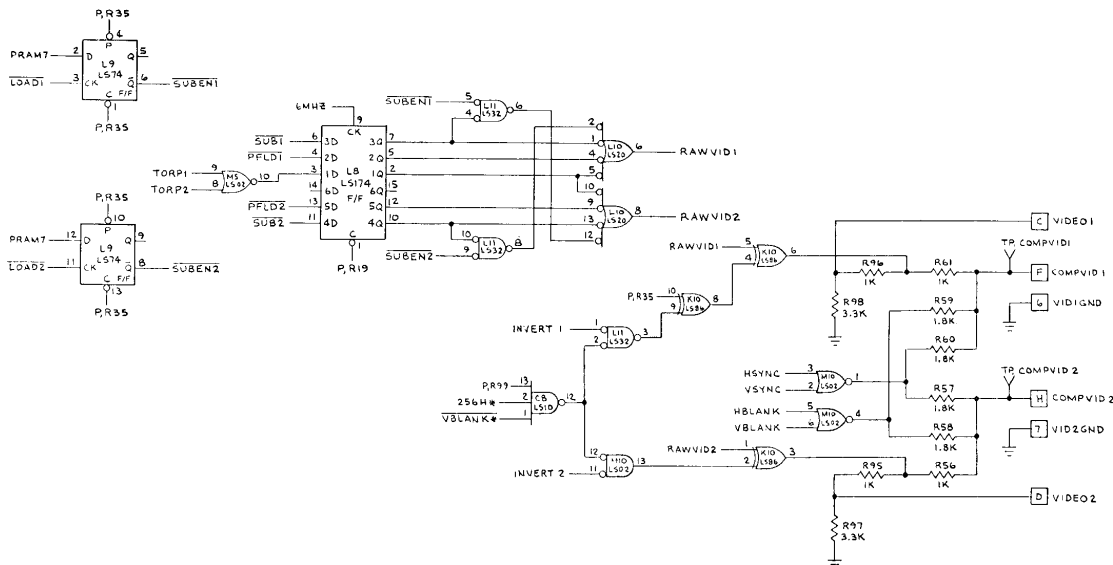

Figure 4-11 Video Summing Circuit

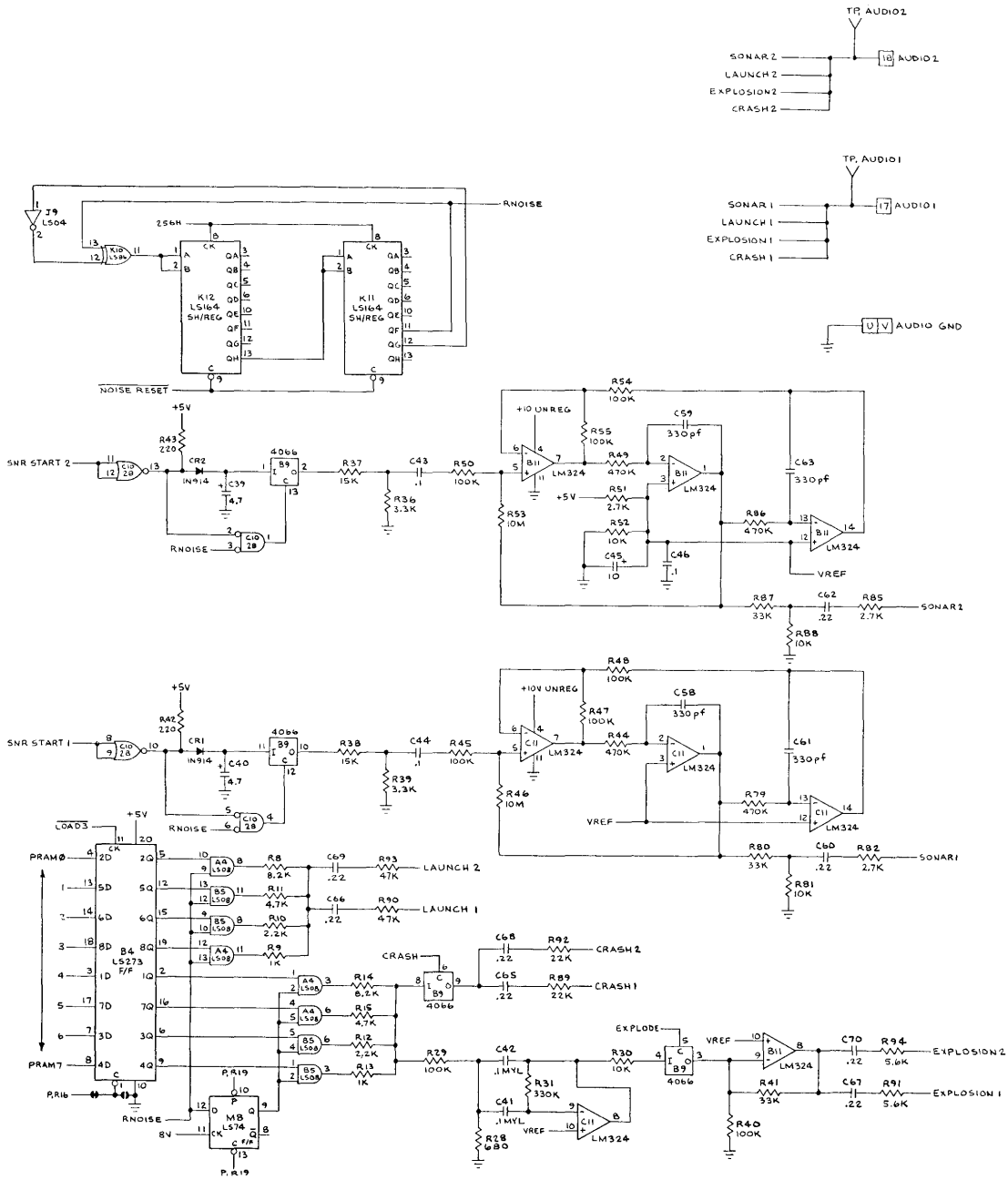

Figure 4-12 Audio Circuitry

f. audio circuitry

(See Figure 4-12)

The Audio circuitry consists of the noise circuit, two sonar sound circuits, and a launch/crash/explosion circuit.

Noise Circuit

The Noise circuit generates pseudo-random noise that is clocked by 256Hz. To prevent a lockup state, the MPU circuitry outputs NOISE RESET signal during initial power-up.

Sonar Circuit

The two sonar signals, SONAR1 and SONAR2, are from two separate and identical circuits. The SONAR1 signal is enabled by a high SNR START1 signal from the MPU circuitry. The enable signal grounds the anode of diode CR1, causing capacitor C40 to discharge through resistors R38 and R39. The result is a decaying voltage at pin 11 of analog switch B9. Analog switch B9 is turned on and off at a rate of RNOISE. Therefore, the output of B9 is RNOISE, which has an envelope that decays at the rate that capacitor C40 discharges. The signal is filtered by Op Amp C11.

Launch/Crash/Explosion Circuit

This circuit receives data from the MPU circuitry's RAM that defines the sound volume. PRAM0 thru PRAM7 is

latched at the output of latch B4 each time $\overline{\text{LOAD3}}$ pulse from the motion circuit occurs.

The latched output of B4 selects the volume output of the binary weighted summing circuits.

The launch sound is the RNOISE sound amplified to the level selected by latched PRAM0 thru PRAM3 data.

The crash sound is RNOISE clocked by 8V through flip-flop M8. The volume is selected by latched PRAM4 thru PRAM7 data and enabled by CRASH from the MPU circuitry's RAM address decoder.

The explosion sound circuit receives 8V clocked RNOISE from the crash sound circuit, filters the signal with Op Amp C11, and, if enabled by EXPLODE from the MPU circuitry's address decoder, is amplified by Op Amp B11.

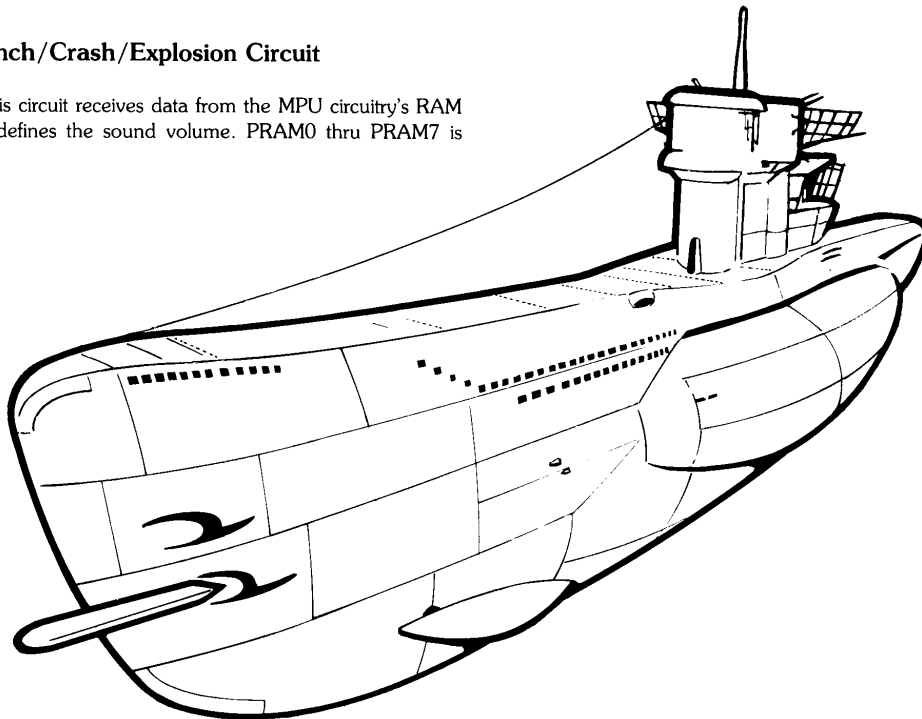

illustrated parts catalog

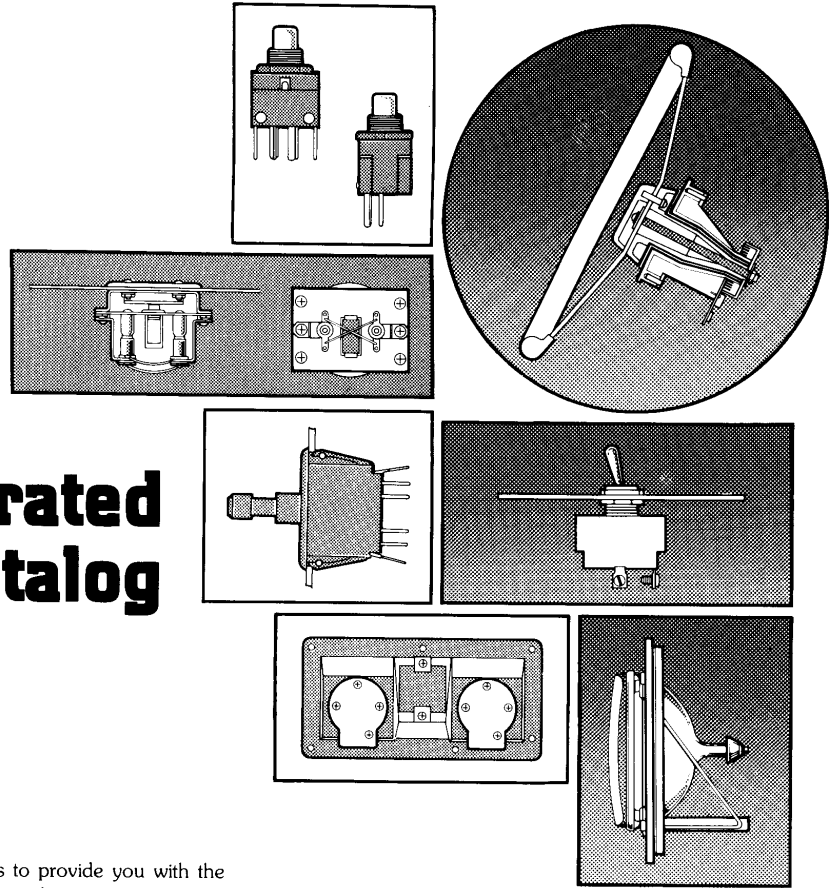

The purpose of this chapter is to provide you with the necessary information for ordering replacement parts for the Subs™ game.

When ordering parts from your distributor, give the part number, part name, applicable figure number of this catalog, and serial number of your game. This will help to avoid confusion and mistakes in your order. We hope the results will be less downtime and more profit from your game.

Subs™

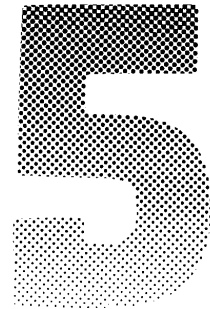

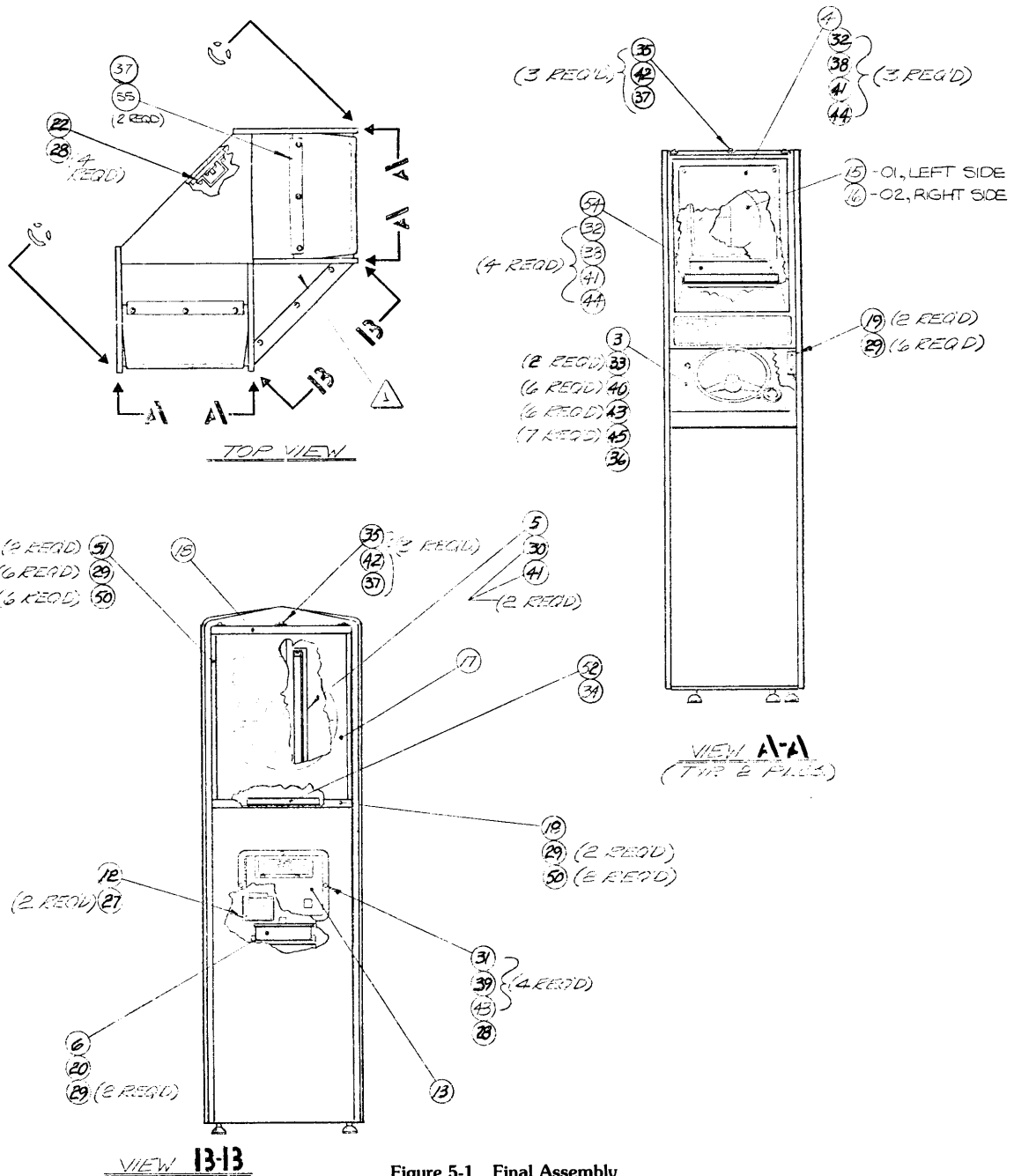

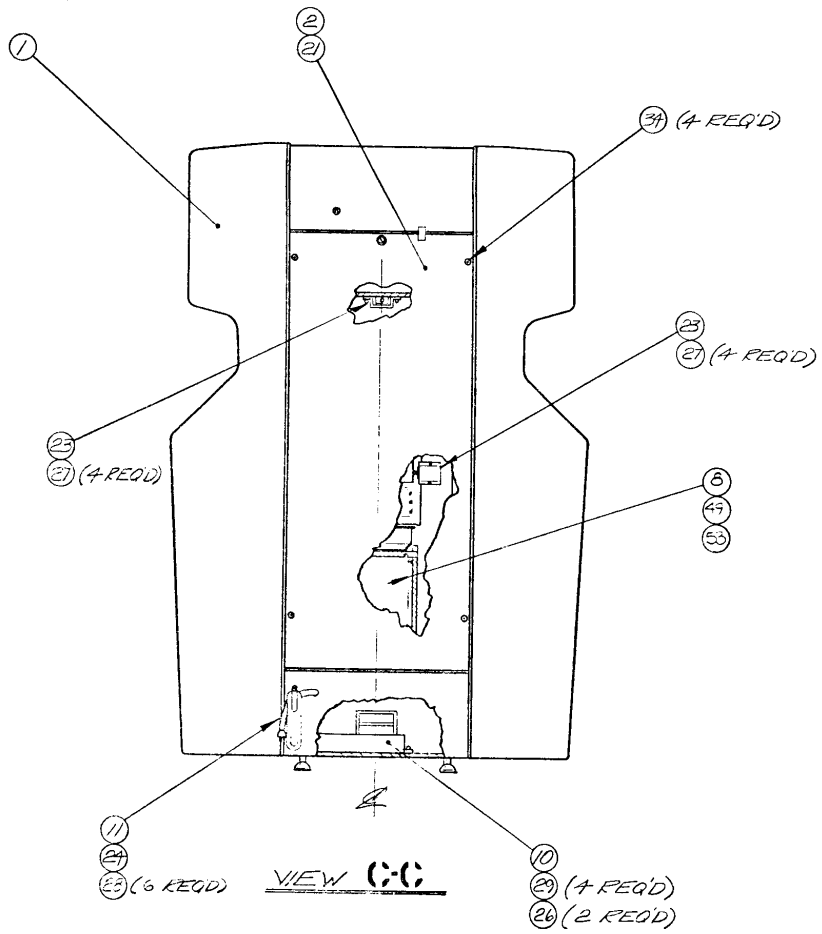

Figure 5-1 Final Assembly, continued

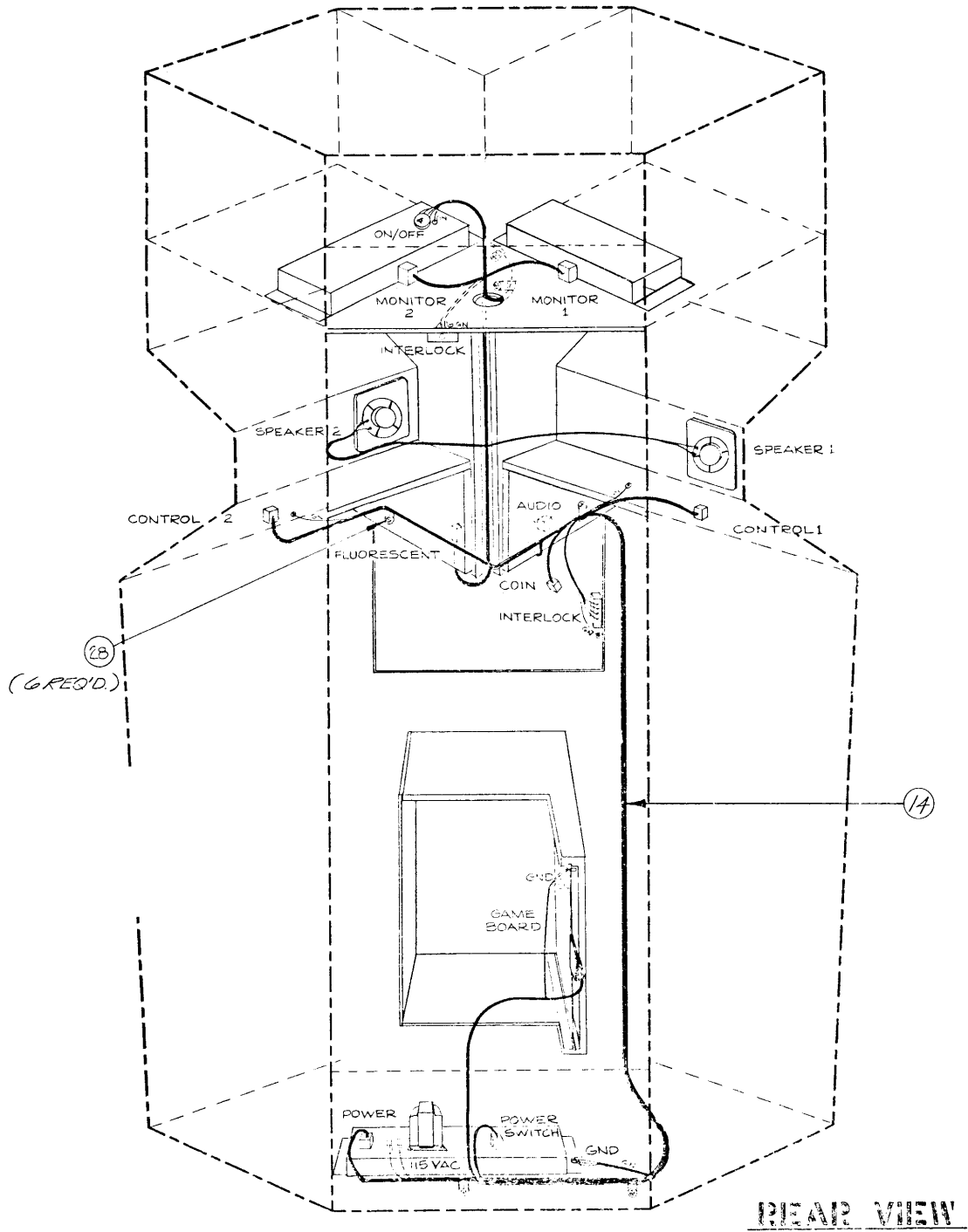

Figure 5-1 Final Assembly, continued

**Figure 5-1 Final Assembly
Parts List**

ITEM	PART NUMBER	QTY.	DESCRIPTION
2	A033992-01	1	Rear Door Assembly
3	A034132-01	2	Control Panel Assembly — see Figure 5-2
4	A034095-01	2	Monitor Trim Bezel — see Figure 5-3
5	A005495-01	1	Fluorescent Light Assembly for Attraction Shield — see Figure 5-4
6	A007902-01	1	Cash Box Assembly, consisting of the following three items:
6a	030244-01	1	Cash Drawer
6b	006317-01	1	Cash Box Lid
6c	006445-01	1	Handle
7	030868-01	2	Connector Mount
8	A0033714-XX	1	Subs PCB Assembly — see Figure 5-5
9	72-1406S	2	#4-40 × 3/8" Pan-Head Cross-Recessed Cadmium-Plated Steel Machine Screw
10	A007197-01	1	Type B Power Supply Assembly — see Figure 5-6
11	A033016-01	1	Power Cord Assembly
12	A009574-02	1	Dual Audio Amplifier Board — see Figure 5-7
13	A009083-01	1	Coin Door Assembly — see Figure 5-8
14	A034235-01	1	Main Harness Assembly
15	A034139-01	1	Vacuum-Formed Overlay (left side) — used with TEC Monitor
16	A034139-02	1	Vacuum-Formed Overlay (right side) — used with TEC Monitor
15	A034611-01	1	Vacuum-Formed Overlay (left side) — used with Zenith Monitor
16	A034611-02	1	Vacuum-Formed Overlay (right side) — used with Zenith Monitor
17	034023-01	1	Attraction Shield
18	033981-01	2	Top/Bottom Attraction Shield Retainer
19	001638-01	4	Control Panel Mounting Bracket
20	006870-01	1	Cash Box Bracket
21	005233-01	1	Rear Door Seal
22	007103-01	1	On/Off Switch Cover
23	007882-02	2	Interlock Switch Cover
24	78-25002	1	Screw-Down Tie Wrap
25	-----	1	Technical Manual for TEC or Zenith 12" Monitor
26	46-2013002	2	3AG 3-Amp. 250V Slow-Blow Fuse
27	72-6608S	10	#6 × 1/2" Cross-Recessed Thread-Forming Pan-Head Type AB Zinc-Plated Steel Screw
28	72-6610S	17	#6 × 5/8" Cross-Recessed Thread-Forming Pan-Head Type AB Zinc-Plated Steel Screw
29	72-6812S	26	#8 × 3/4" Cross-Recessed Thread-Forming Pan-Head Type AB Zinc-Plated Steel Screw
30	72-6810	2	#8 × 5/8" Cross-Recessed Thread-Forming Pan-Head Type AB Screw
31	75-5516B	4	#1/4-20 × 1" Round-Head Square-Neck Black Oxide Steel Carriage Bolt
32	75-5120N	14	#10-24 × 1 1/4" Round-Head Square-Neck Nickel-Plated Steel Carriage Bolt
33	75-5532B	4	#1/4-20 × 2" Round-Head Square-Neck Black Oxide Steel Carriage Bolt
34	82-1824S	5	#8 × 1 1/2" Phillips Flat-Head Countersunk Wood Screw
35	82-8016	9	#10-32 × 1" Button-Head Allen-Socket Hardened-Steel Machine Screw

Figure 5-1 Final Assembly, continued
Parts List

ITEM	PART NUMBER	QTY.	DESCRIPTION
36	75-935S	2	#1/4-20 Steel Wing Nut
37	78-6900402	A/R	1/4" Wide x 1/8" Thick Black Single-Sided Adhesive Foam Tape
38	75-911S	14	#10-24 Standard Hex-Pattern Cadmium-Plated Steel Machine Nut
39	75-990505S	4	#1/4-20 Self-Locking Prevailing-Torque Shallow-Pattern Steel Hex Nut
40	75-915S	12	#1/4-20 Standard Hex-Pattern Cadmium-Plated Steel Machine Nut
41	75-010S	16	#10 Flat Plain Regular-Pattern SAE-Standard Steel Washer
42	75-07021	9	#10 Black Nylon Type 6/6 Washer
43	75-015S	16	#1/4 Flat Plain Regular-Pattern SAE-Standard Steel Washer
44	75-040	14	#10 Corrosion-Resistant Steel Split Lock Washer
45	75-054S	14	#1/2 Internal-Tooth Steel Lock Washer
48	TM-132	1	Subs Technical Manual with Illustrated Parts Catalog
49	74-3606A	1	#6 x 3/8" Aluminum Round Spacer
50	75-048	8	#8 Corrosion-Resistant Steel Split Lock Washer
51	034137-01	2	Side Attraction Shield Retainer
52	034135-01	1	Stop Cleat
53	72-6612S	1	#6 x 3/4" Cross-Recessed Thread-Forming Pan-Head Type AB Zinc-Plated Steel Screw
54	034138-01	2	TEC 12" Monitor
54	A034608-01	2	Zenith 12" Monitor Assembly—see Figure 5-11
			<p>Note: The TEC monitor and Zenith monitor assembly are directly interchangeable with each other. However, if you are replacing a Zenith monitor with a new Zenith monitor, then you do <i>not</i> need to order the entire Zenith assembly. Refer to Figure 5-11 for individual part numbers in the Zenith monitor assembly.</p>
55	034140-01	2	Housing Hold-Down Strip

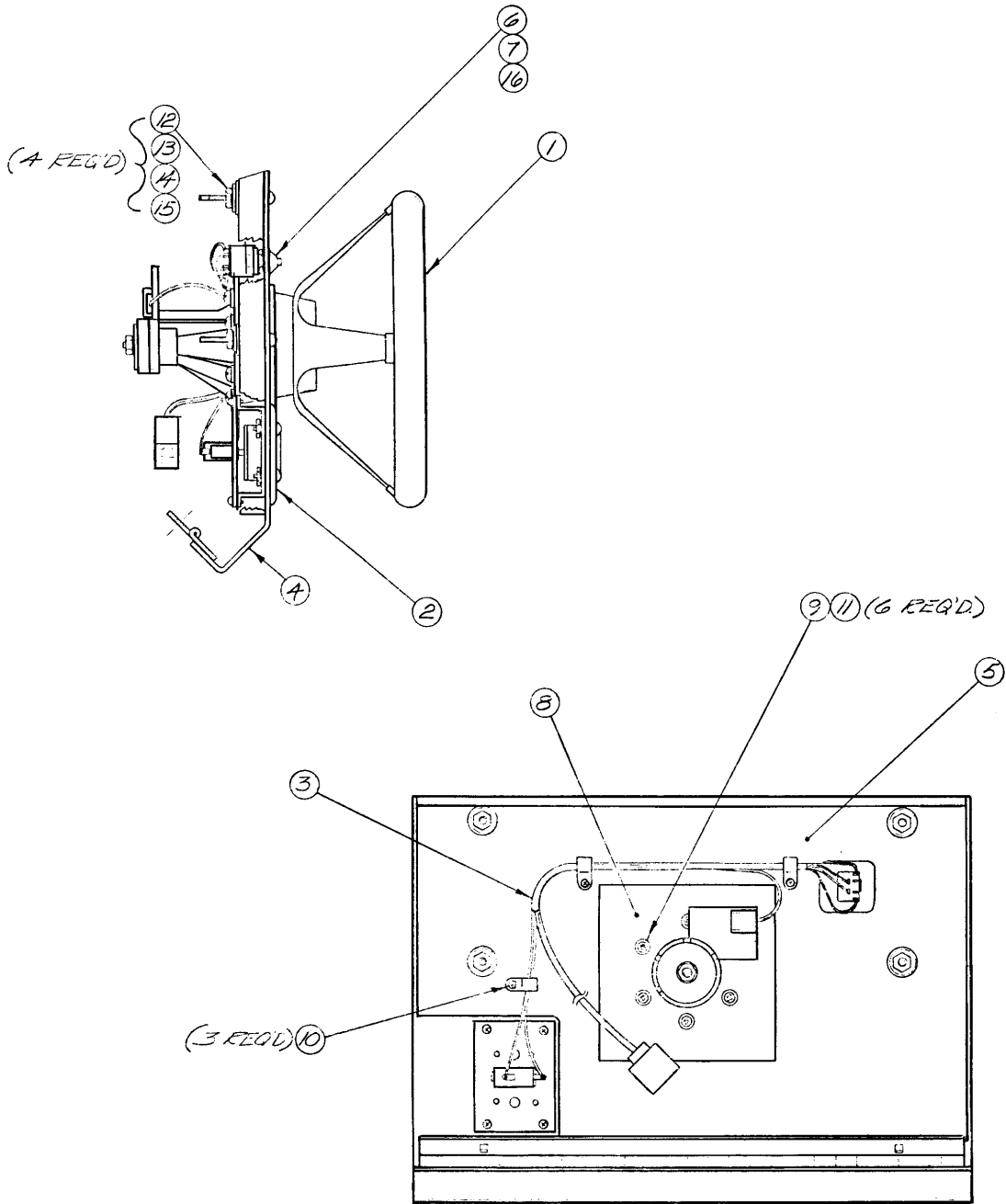

Figure 5-2 Control Panel Assembly
A034132-01 A

**Figure 5-2 Control Panel Assembly
Parts List**

ITEM	PART NUMBER	QTY.	DESCRIPTION
1	A000598-08	1	Steering Wheel Assembly -- see Figure 5-9
2	A009338-01	1	Fire Button Assembly -- see Figure 5-10
3	A034236-01	1	Control Panel Harness Assembly
4	034033-01	1	Silk-Screened Control Panel
5	033989-01	1	Plywood Control Panel Board
6	62-002	1	SPDT Light-Emitting Diode Switch
7	033127-01	1	Black Molded Switch Bushing
8	000567-01	1	Bow Washer
9	85-22F112	6	#10-24 x 3/4" Phillips Pan-Head Type F Self-Tapping Machine Thread Screw
10	72-6610S	3	#6 x 5/8" Cross-Recessed Thread-Forming Pan-Head Type AB Zinc-Plated Steel Screw
11	75-040	6	#10 Corrosion-Resistant Steel Split Lock Washer
12	75-5532B	4	#1/4-20 x 2" Round-Head Square-Neck Black Oxide Steel Carriage Bolt
13	75-915S	4	#1/4-20 Standard Hex-Pattern Cadmium-Plated Steel Machine Nut
14	75-015S	4	#1/4 Flat Plain Regular-Pattern SAE-Standard Steel Washer
15	75-045	4	#1/4 Corrosion-Resistant Steel Split Lock Washer
16	75-07054	1	Flat Nylon Washer, .470" Inside Diameter x .968" Outside Diameter x .75" Thick

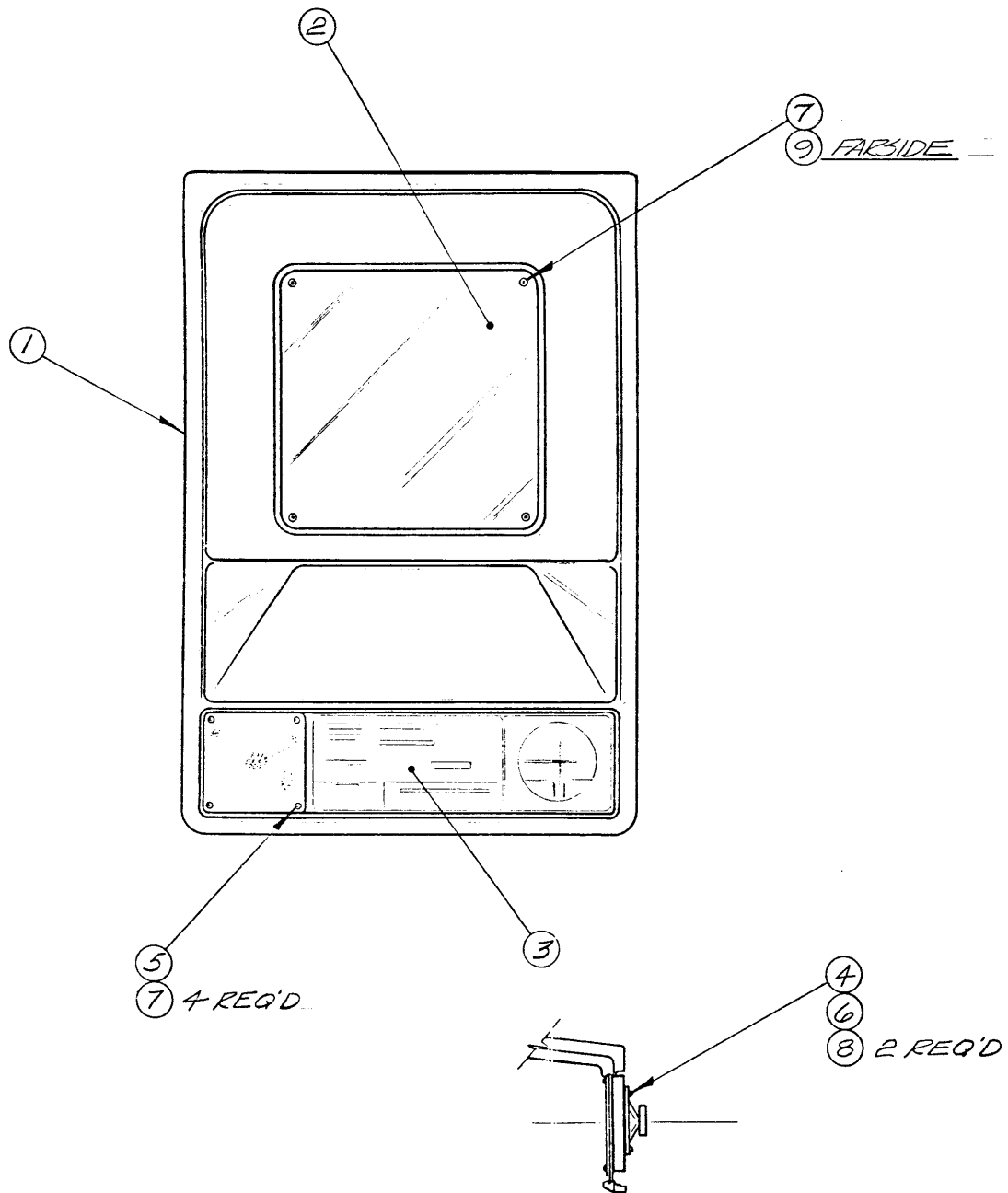
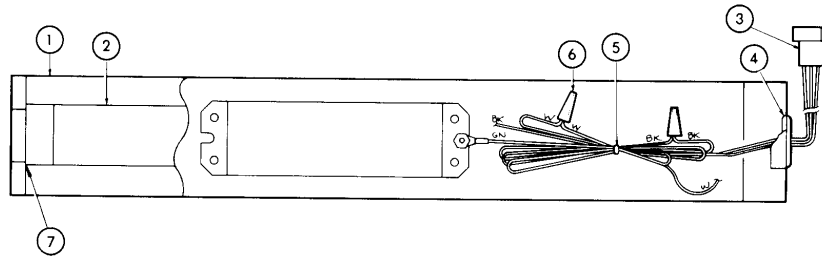

Figure 5-3 Housing Assembly
A034095-01 A

**Figure 5-3 Housing Assembly
Parts List**

ITEM	PART NUMBER	QTY.	DESCRIPTION
1	033857-01	1	Formed Plastic Housing
2	034018-01	1	Monitor Shield
3	034000-01	1	Instrument Panel Decal
4	034016-01	1	Speaker Mounting Block
5	000869-01	1	5" Speaker Grill
6	48-004	1	5" 8-Ohm Loudspeaker
7	73-77015	8	3/16 x .68" Black-Anodized Aluminum Pull-Mandrel Blind Rivet
8	72-6608S	2	#6 x 1/2" Cross-Recessed Thread-Forming Pan-Head Type AB Zinc-Plated Steel Screw
9	75-010S	4	#10 Flat Plain Regular-Pattern SAE-Standard Steel Washer



**Figure 5-4 Fluorescent Light Assembly
A005495-01 D**

ITEM	PART NUMBER	QTY.	DESCRIPTION
1	93-104	1	18" Fluorescent Fixture, 110V
2	70-303	1	#F15T8 18-Inch 15-Watt Cool White Fluorescent Tube
3	A005493-01	1	Fluorescent Light Harness
4	78-2652	1	1 1/8" Outside Diameter x 5/8" Inside Diameter Rubber Grommet
5	78-24001	A/R	Free-Hanging Tie Wrap
6	79-561816	2	16- to 18-Guage Spring Connector Wire Nut
7	99-11006	2	Lamp Retaining Clip and Ring

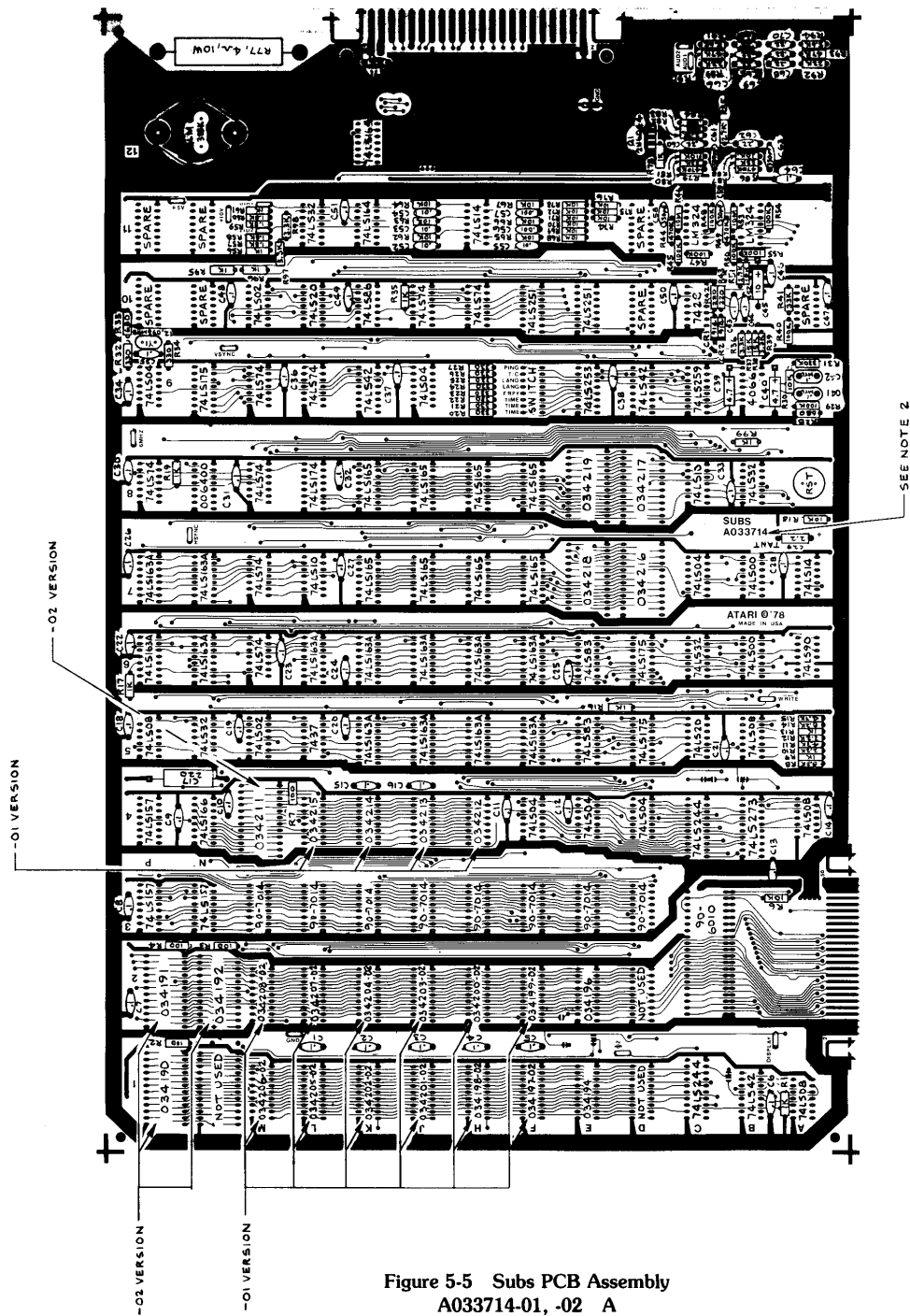

Figure 5-5 Subs PCB Assembly
A033714-01, -02 A

**Figure 5-5 Subs PCB Assembly
Parts List**

ITEM	PART NUMBER	QTY.	DESCRIPTION	REFERENCE DESIGNATION/ LOCATION
1	033715-01	1	Printed-Circuit Board	
2	10-5101	6	100 Ohm, $\pm 5\%$, $\frac{1}{4}W$ Carbon Composition Resistor	R2, 4, 5, 7, 83, 84
3	10-5221	2	220 Ohm, $\pm 5\%$, $\frac{1}{4}W$ Carbon Composition Resistor	R42, 43
4	10-5331	10	330 Ohm, $\pm 5\%$, $\frac{1}{4}W$ Carbon Composition Resistor	R20-27, 32, 34
5	10-5681	2	680 Ohm, $\pm 5\%$, $\frac{1}{4}W$ Carbon Composition Resistor	R28, 33
6	10-5102	13	1K Ohm, $\pm 5\%$, $\frac{1}{4}W$ Carbon Composition Resistor	R1, 9, 13, 16, 17, 19, 35, 56, 61, 78, 95, 96, 99
7	10-5182	4	1.8K Ohm, $\pm 5\%$, $\frac{1}{4}W$ Carbon Composition Resistor	R57-60
8	10-5222	2	2.2K Ohm, $\pm 5\%$, $\frac{1}{4}W$ Carbon Composition Resistor	R10, 12
9	10-5272	3	2.7K Ohm, $\pm 5\%$, $\frac{1}{4}W$ Carbon Composition Resistor	R51, 82, 85
10	10-5332	4	3.3K Ohm, $\pm 5\%$, $\frac{1}{4}W$ Carbon Composition Resistor	R36, 39, 97, 98
11	10-5472	2	4.7K Ohm, $\pm 5\%$, $\frac{1}{4}W$ Carbon Composition Resistor	R11, 15
12	10-5562	2	5.6K Ohm, $\pm 5\%$, $\frac{1}{4}W$ Carbon Composition Resistor	R91, 94
13	10-5822	2	8.2K Ohm, $\pm 5\%$, $\frac{1}{4}W$ Carbon Composition Resistor	R8, 14
14	10-5103	21	10K Ohm, $\pm 5\%$, $\frac{1}{4}W$ Carbon Composition Resistor	R6, 18, 30, 52, 62-76, 81, 88
15	10-5153	2	15K Ohm, $\pm 5\%$, $\frac{1}{4}W$ Carbon Composition Resistor	R37, 38
16	10-5223	2	22K Ohm, $\pm 5\%$, $\frac{1}{4}W$ Carbon Composition Resistor	R89, 92
17	10-5333	3	33K Ohm, $\pm 5\%$, $\frac{1}{4}W$ Carbon Composition Resistor	R41, 80, 87
18	10-5473	2	47K Ohm, $\pm 5\%$, $\frac{1}{4}W$ Carbon Composition Resistor	R90, 93
19	10-5104	8	100K Ohm, $\pm 5\%$, $\frac{1}{4}W$ Carbon Composition Resistor	R29, 40, 45, 47, 48, 50, 54, 55
20	10-5334	1	330K Ohm, $\pm 5\%$, $\frac{1}{4}W$ Carbon Composition Resistor	R31
21	10-5474	4	470K Ohm, $\pm 5\%$, $\frac{1}{4}W$ Carbon Composition Resistor	R44, 49, 75, 86
22	10-5106	2	10M Ohm, $\pm 5\%$, $\frac{1}{4}W$ Carbon Composition Resistor	R46, 53
24	19-805W4P0	1	4 Ohm 10W Wirewound Resistor	R77
27	21-101104	2	Radial-Lead Epoxy-Dipped 100V .1 μ f Mylar Fixed Capacitor	C41, 42
29	24-250475	2	Electrolytic 25V 4.7 μ f Radial-Lead Capacitor	C39, 40
30	24-250106	1	Electrolytic 25V 10 μ f Radial-Lead Capacitor	C45
31	24-250227	1	Electrolytic 25V 220 μ f Radial-Lead Capacitor	C17
33	27-250102	2	Ceramic-Disc 25V .001 μ f Radial-Lead Capacitor	C56, 57
34	27-250103	4	Ceramic-Disc 25V .01 μ f Radial-Lead Capacitor	C52-55
35	27-250104	45	Ceramic-Disc 25V .1 μ f Radial-Lead Capacitor	C1-16, 18-28, 30-38, 43, 44, 46-51, 64
36	27-250224	9	Ceramic-Disc 25V .22 μ f Radial-Lead Capacitor	C60, 62, 65-71
38	28-101331	4	Radial-Lead Epoxy-Dipped 100V 330pf Mica Capacitor	C58, 59, 61, 63
39	29-010	1	Axial-Lead 10V 2.2 μ f Tantalum Capacitor	C29
41	31-1N914	2	75V 1N914 Switching Diode	CR1, 2
43	34-2N6040	1	2N6044 Transistor	Q1
46	37-74LS00	2	Type 74LS00 TTL Quad 2-In NAND Gate Integrated Circuit	B6, 7
47	37-74LS02	2	Type 74LS02 TTL Quad 2-In NOR Gate Integrated Circuit	M5, 10

**Figure 5-5 Subs PCB Assembly, continued
Parts List**

ITEM	PART NUMBER	QTY.	DESCRIPTION	REFERENCE DESIGNATION/ LOCATION
48	37-74LS04	6	Type 74LS04 TTL Hexadecimal Inverter Integrated Circuit	D4, E4, F4, C7, J9, P9
49	37-74LS08	4	Type 74LS08 TTL Quad 2-In AND Gate Integrated Circuit	A1, A4, B5, P5
50	37-74LS10	2	Type 74LS10 TTL Triple 3-In NAND Gate Integrated Circuit	L7, C8
51	37-74LS14	2	Type 74LS14 TTL Hexadecimal Schmitt Trigger Inverter Integrated Circuit	A7, H11
52	37-74LS20	2	Type 74LS20 TTL Dual 4-In NAND Gate Integrated Circuit	C5, L10
53	37-7428	1	Type 7428 TTL Quad 2-In NOR Buffer Integrated Circuit	C10
54	37-74LS32	4	Type 74LS32 TTL Quad 2-In OR Gate Integrated Circuit	N5, C6, B8, L11
55	37-7437	1	Type 7437 TTL Quad 2-In NAND Buffer Integrated Circuit	L5
56	37-74LS42	3	Type 74LS42 TTL 1-of-10 BCD to Decimal Integrated Circuit	B1, D9, K9
57	37-74LS74	8	Type 74LS74 TTL Dual-D Edge Trigger Flip-Flop Integrated Circuit	M6-8, P8, L9, M9, H10, J10
58	37-74LS83	2	Type 74LS83 TTL 4-Bit Binary Full Adder Integrated Circuit	E5, 6
59	37-74LS86	1	Type 74LS86 TTL Quad 2-In Exclusive OR Gate Integrated Circuit	K10
60	37-74LS90	1	Type 74LS90 TTL Decade Counter Integrated Circuit	A6
62	37-74LS157	3	Type 74LS157 TTL Quad 2-to-1 Data Selector/Multiplexer Integrated Circuit	N3, P3, P4
63	37-74LS163A	13	Type 74LS163A TTL Sync. 4-Bit Counter Sync Clear Integrated Circuit	F5, H5, J5, K5, F6, H6, J6, K6, L6, N6, P6, N7, P7
64	37-74LS164	2	Type 74LS164 TTL 8-Bit Serial-In/Parallel-Out Shift Register Integrated Circuit	K11, 12
65	37-74LS165	8	Type 74LS165 TTL Parallel-Load 8-Bit Shift Register Integrated Circuit	F7, H7, J7, K7, F8, H8, J8, K8
66	37-74LS166	1	Type 74LS166 TTL 8-Bit Shift Register Integrated Circuit	N4
67	37-74LS174	1	Type 74LS174 TTL Hexadecimal D-Type Flip-Flop Integrated Circuit	L8
68	37-74LS175	3	Type 74LS175 TTL Quad-D Flip-Flop Integrated Circuit	D5, D6, N9
69	37-74LS244	2	Type 74LS244 TTL Octal Buffers and Line Drivers Integrated Circuit	C1, 4
70	37-74LS251	2	Type 74LS251 TTL Tri-State Data Selector/Multiplexer Integrated Circuit	E10, F10

**Figure 5-5 Subs PCB Assembly, continued
Parts List**

ITEM	PART NUMBER	QTY.	DESCRIPTION	REFERENCE DESIGNATION/ LOCATION
71	37-74LS253	1	Type 74LS253 TTL Tri-State Dual Data Selector/ Multiplexer Integrated Circuit	E9
72	37-74LS259	1	Type 74LS259 TTL 8-Bit Addressable Latch Integrated Circuit	C9
73	37-74LS273	1	Type 74LS273 TTL Octal D Flip-Flop Integrated Circuit	B4
75	37-4066	1	Type 4066 CMOS Quad Analog Switch Integrated Circuit	B9
76	37-LM323K	1	3-Amp. 5V Positive Voltage Regulator	
77	37-LM324	2	Type LM324 Linear Quad Operational Amplifier Integrated Circuit	B11, C11
81	62-001	1	SPST Push-Button Switch	A8
82	66-118PIT	1	8-Station Single-Throw Dual-Inline-Package Bit Switch	F9
85	72-1608C	2	#6-32 x 1/2" Pan-Head Cross-Recessed Corrosion- Resistant Steel Machine Screw	
86	75-016C	2	#6 Flat Plain SAE-Standard Regular-Pattern Corrosion-Resistant Steel Washer	
87	75-056	2	#6 Internal-Tooth Steel Lock Washer	
88	75-916C	2	#6-32 Standard Hex Pattern Corrosion-Resistant Steel Nut	
90	78-06001	1	Flat Black Anodized Aluminum Heat Sink	
91	78-16005	1	Thermal Conductive Compound, Berquist #7403- 10-04	
93	79-42040	1	40-Position Medium-Insertion-Force IC Socket	C2/3
94	020670-01	14	Test Points	
96	90-102	1	12.096 MHz, ± .005%, Crystal	Y1
98	90-6010	1	Microprocessor	C2/3
99	90-7014	8	Random-Access Memory	D3, E3, F3, H3, J3, K3, L3, M3
101	006400-01	1	Sync PROM	N8
103	034216-01	1	Motion Object PROM	D7
104	034217-01	1	Motion Object PROM	D8
105	034218-01	1	Motion Object PROM	E7
106	034219-01	1	Motion Object PROM	E8
<i>For remaining memory components and their part numbers, see next page.</i>				

Figure 5-5 Subs PCB Assembly, continued

Parts List

Memory Equivalency Table and Part Numbers

If circuitry is faulty, self-test will display the following message during ROM test:	-01 P.C. Boards (PROMs)	Alternate -01 P.C. Boards (PROMs)	-02 P.C. Boards (ROMs)
A	2000-20FF (LSB) 034194-01 E1	2000-20FF (LSB) 034194-01 E1	2000-20FF (LSB) 034194-01 E1
B	2000-20FF (MSB) 034196-01 E2	2000-20FF (MSB) 034196-01 E2	2000-20FF (MSB) 034196-01 E2
E	2800-2BFF (LSB) 034198-01 H1	2800-2FFF (LSB) 034183-01 H1	2800-2FFF P1 034190-01
G	2C00-2FFF (LSB) 034197-01 F1		
F	2800-2BFF (MSB) 034200-01 H2		
H	2C00-2FFF (MSB) 034199-01 F2	2800-2FFF (MSB) 034184-01 H2	
I	3000-33FF (LSB) 034202-01 K1	3000-37FF (LSB) 034185-01 K1	3000-37FF P2 034191-01
K	3400-37FF (LSB) 034201-01 J1		
J	3000-33FF (MSB) 034204-01 K2	3000-37FF (MSB) 034186-01 K2	
L	3400-37FF (MSB) 034203-01 J2		
M	3800-3BFF (LSB) 034206-01 M1	3800-3FFF (LSB) 034187-01 M1	3800-3FFF N2 034192-01
O	3C00-3FFF (LSB) 034205-01 L1		
N	3800-3BFF (MSB) 034208-01 M2	3800-3FFF (MSB) 034188-01 M2	
P	3C00-3FFF (MSB) 034207-01 L2		
Not checked by the self-test	034212-02 H4	034209-01 J4	034211-01 M4
	034213-02 J4		
	034214-02 K4 034215-02 L4	034210-01 L4	

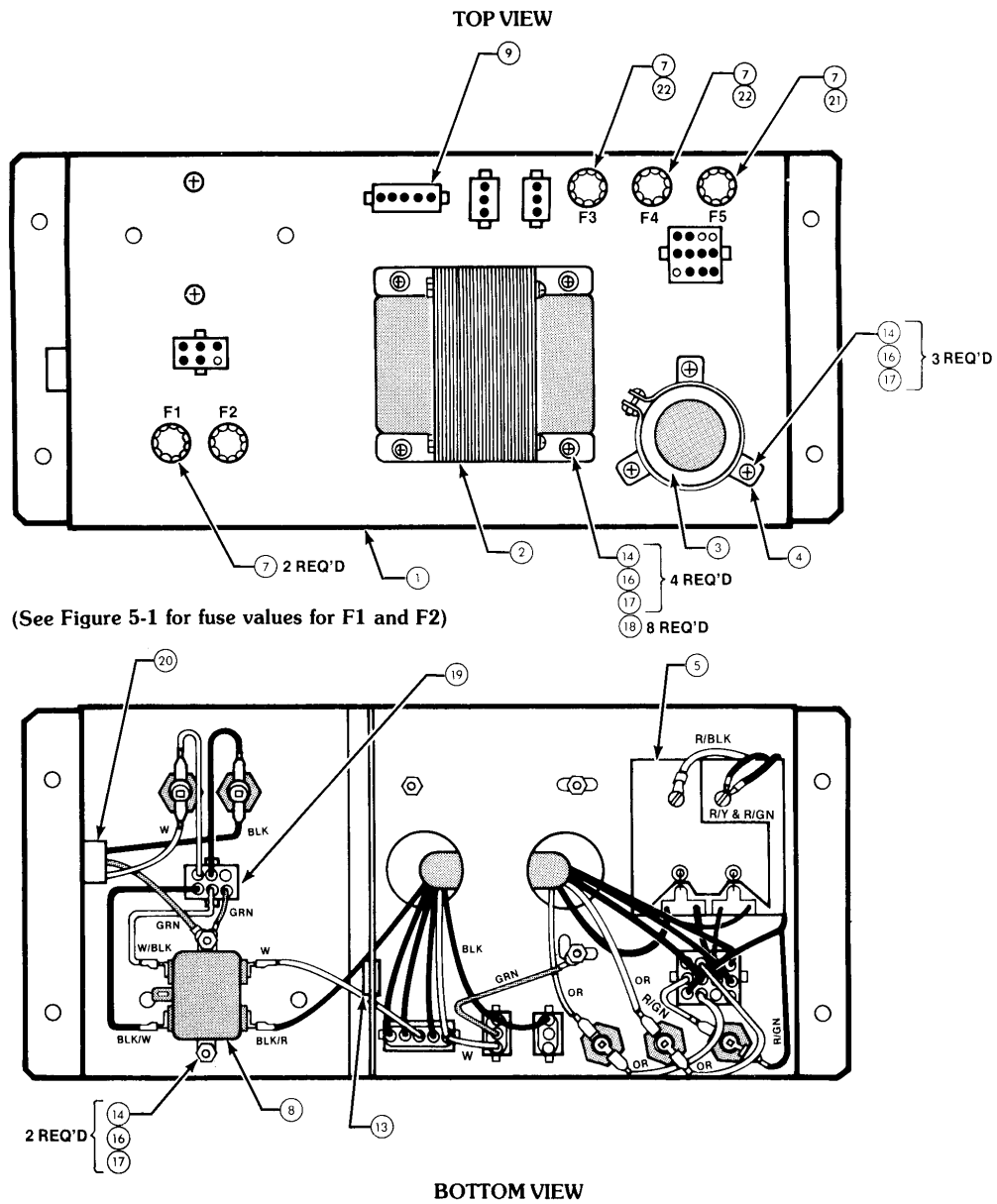

**Figure 5-6 Type B Power Supply Assembly
A007197-01 J**

**Figure 5-6 Type B Power Supply Assembly
Parts List**

ITEM	PART NUMBER	QTY.	DESCRIPTION
1	A009266-01	1	Power Supply Base Weldment Assembly
2	A006886-01	1	Type B Transformer Termination Assembly
3	29-053	1	26,000 μ f 15V Electrolytic Capacitor
4	78-70501SC	1	2" Diameter Cadmium-Plated Steel Component Mounting Bracket
5	A006555-01	1	P.C. Board Rectifier
7	79-4411004	5	Panel-Mounting Non-Indicating 3AG Fuse Post
8	41-2003	1	115/250 VAC 5-amp 5-400 Hz AC Line Filter
9	A006958-01	1	95V Voltage Selection Block (Black Wires)
10	A006958-02	1	110V Voltage Selection Block (Orange Wires)
11	A006958-03	1	205V Voltage Selection Block (Green Wires)
12	A006958-04	1	220V Voltage Selection Block (Red Wires)
13	78-2708	1	Nylon Tape 6/6 Hole Bushing, 5/8" Inside Diameter \times 55/64" Outside Diameter \times 1/4" Thick
14	72-1810S	9	#8-32 \times 5/8" Pan-Head Cross-Recessed Cadmium-Plated Steel Machine Screw
16	75-048	9	#8 Corrosion-Resistant Steel Split Lock Washer
17	75-918S	9	#8-32 Standard Hex-Pattern Cadmium-Plated Steel Nut
18	75-018S	8	#8 Flat Plain SAE-Standard Regular-Pattern Steel Washer
19	A007192-01	1	Power Switch Termination
20	A007444-01	1	Power In Harness
21	46-2038001	1	8-amp 125V 3AG Normal-Acting Fuse
22	46-2012501	2	2 1/2-amp 125V 3AG Slow-Acting Fuse

**Figure 5-7 Dual Audio Amplifier PCB Assembly
Parts List**

ITEM	PART NUMBER	QTY.	DESCRIPTION	REFERENCE DESIGNATION/ LOCATION
1	009575-01	1	Printed Circuit Board	
2	10-51P0	2	1 Ohm, $\pm 5\%$, $\frac{1}{4}W$ Carbon Composition Resistor	R3, 10
3	10-5101	2	100 Ohm, $\pm 5\%$, $\frac{1}{4}W$ Carbon Composition Resistor	R6, 9
4	10-5100	2	10 Ohm, $\pm 5\%$, $\frac{1}{4}W$ Carbon Composition Resistor	R4, 7
5	11-5221	2	220 Ohm, $\pm 5\%$, $\frac{1}{4}W$ Carbon Composition Resistor	R5, 8
6	19-316103	2	10K Ohm Trimpot	R1, 2
7	24-250106	2	10 μ f @ 25V Radial-Lead Electrolytic Capacitor	C12, 13
8	24-250107	2	100 μ f @ 25V Radial-Lead Electrolytic Capacitor	C2, 7
9	24-250108	2	100 μ f @ 25V Radial-Lead Electrolytic Capacitor	C1, 6
10	24-250228	2	2200 μ f @ 25V Radial-Lead Electrolytic Capacitor	C5, 10
11	27-101103	2	.01 μ f @ 100V Radial-Lead Ceramic-Disc Capacitor	C3, 8
12	27-250104	4	.1 μ f @ 25V Radial-Lead Ceramic-Disc Capacitor	C4, 9, 11, 14
13	31-A14F	2	50V 2.5 Amp Miniature Axial-Lead High-Current Rectifier Diode	CR1, 2
14	31-1N4001	10	Medium-Current 50V Silicon Rectifier Diode	CR3-12
15	37-TDA2002V	2	Type TDA2002V Audio Amplifier	U1, 2
16	69-004	1	SPDT P.C. Board-Mounting Miniature Slide Switch	SW1
17	78-58005	1	10-Position Connector	
18	030184-01	1	Heat Sink	
19	72-1604C	4	#6-32 \times $\frac{1}{4}$ " Cross-Recessed Pan-Head Corrosion-Resistant Steel Machine Screw	
20	75-056	4	#6 Internal-Tooth Steel Lock Washer	
21	78-16009	2	Thermal Conductive Compound, Berquist #7403-09FR-50	
22	10-5103	2	10K Ohm, $\pm 5\%$, $\frac{1}{4}W$ Carbon Composition Resistor	R11, 12
23	52-003	1	18-Gauge Teflon-Insulated Solder-Plated Solid Copper PC-Mounting Jumper Wire, with .6" Center-to-Center Length	

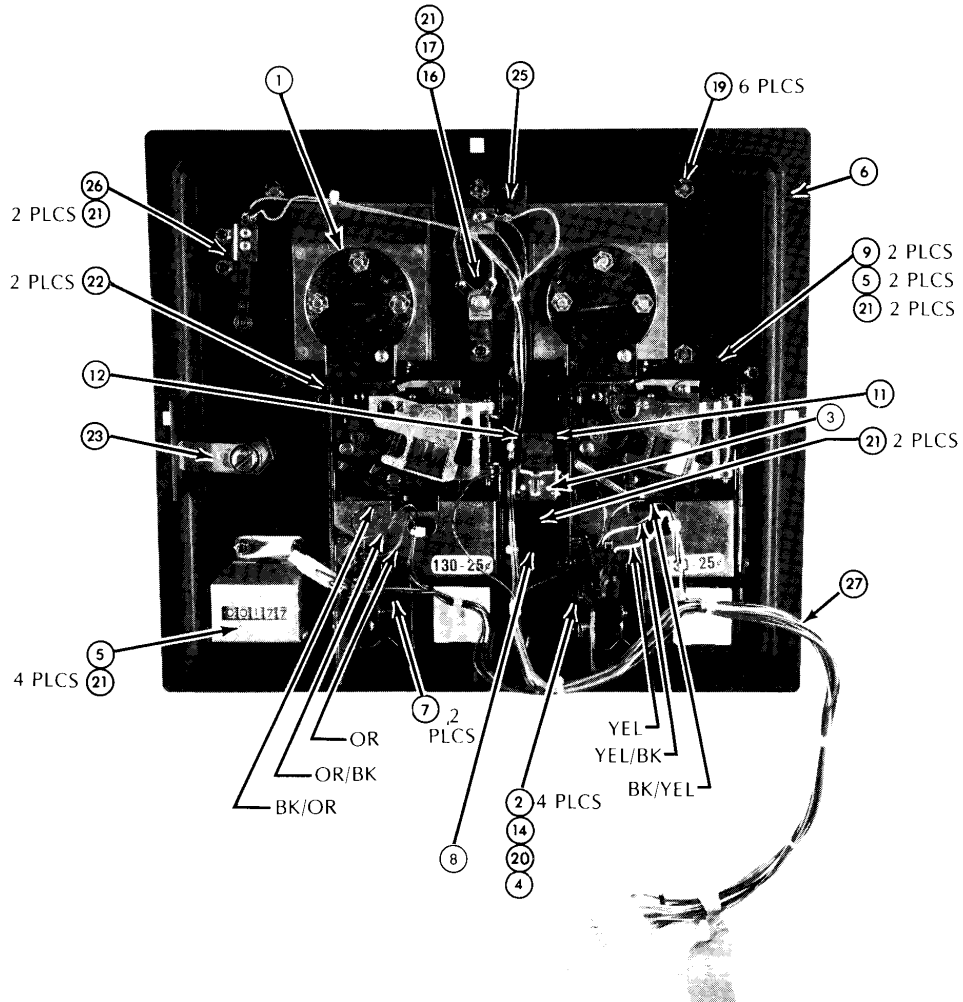

Figure 5-8 Coin Door Assembly
A009083-01 thru -07 F

**Figure 5-8 Coin Door Assembly
Parts List**

ITEM	PART NUMBER	QTY.	DESCRIPTION
1	A007637-01	1	Front Bezel Assy.—Used only on -01 Coin Door Assy. (25¢)
	A007637-02	Ref.	Front Bezel Assy.—Used only on -02 Coin Door Assy. (5 Fr)
	A007637-03	Ref.	Front Bezel Assy.—Used only on -03 Coin Door Assy. (1 DM)
	A007637-04	Ref.	Front Bezel Assy.—Used only on -04 Coin Door Assy. (1 Kr)
	A007637-05	Ref.	Front Bezel Assy.—Used only on -05 Coin Door Assy. (100 Y)
	A007637-06	Ref.	Front Bezel Assy.—Used only on -06 Coin Door Assy. (10 pence)
	A007637-07	Ref.	Front Bezel Assy.—Used only on -07 Coin Door Assy. (20¢ Australian)
2	75-916S	4	#6-32 Standard Hex Pattern Cadmium-Plated Steel Machine Nut
3	A030362-01	1	Coin Lock-Out Assembly
4	A007640-01	2	Coin Switch Assembly
5	A002465-01	1	Coin Counter Assembly
6	004320-01	1	Coin Door Weldment
7	004341-01	2	Secondary Coin Chute
8	004344-01	1	Key Loop
9	004340-01	2	Spring Return
10	004337-01	2	Bracket, Wire Form
11	004338-01	1	Lock-Out Wire Form, R.H.
12	004336-01	1	Lock-Out Wire Form, L.H.
13	004326-01	2	Button, Scavenger
14	75-046	4	#6 Corrosion-Resistant Steel Split Lock Washer
15	006904-01	2	Spacer
16	007359-01	1	Lamp Socket
17	70-11-47	1	NEMA #47 Incandescent Minature Bayonet-Base Lamp
18	73-3008	2	Carbon Spring Steel External Retaining Ring, for 1/4" Diameter Shaft
19	75-9914001	6	Stamped Steel Self-Threading Nut
20	75-026S	4	#6 Flat Plain Narrow-Pattern SAE-Standard Steel Washer
21	75-99516	13	#6-32 Steel Nut and Spring Washer Assembly
22	008629-01	2	Spring
23	71-2118	1	Single-Bit Panel Cartridge Lock, Hudson #CR73A045S
24	71-1225CU	2	Coin Mechanism for American Quarter Only
	71-125FB	Ref.	Coin Mechanism for Belgian 5 Francs Only
	71-1205MG	Ref.	Coin Mechanism for German Mark Only
	71-1201KS	Ref.	Coin Mechanism for Swedish Krona Only
	71-1201YJ	Ref.	Coin Mechanism for Japanese 100 Yen Only
	71-1210PE	Ref.	Coin Mechanism for English 10 Pence Only
	71-1220CA	Ref.	Coin Mechanism for Australian 20-Cent Piece Only
25	007753-01	1	Plate, Anti-Probe
26	A007638-01	1	Switch Assembly, Slam
27	A006921-01	1	Harness Assembly

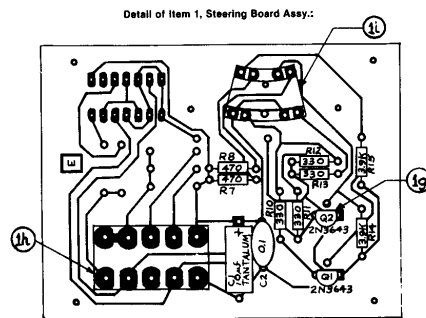
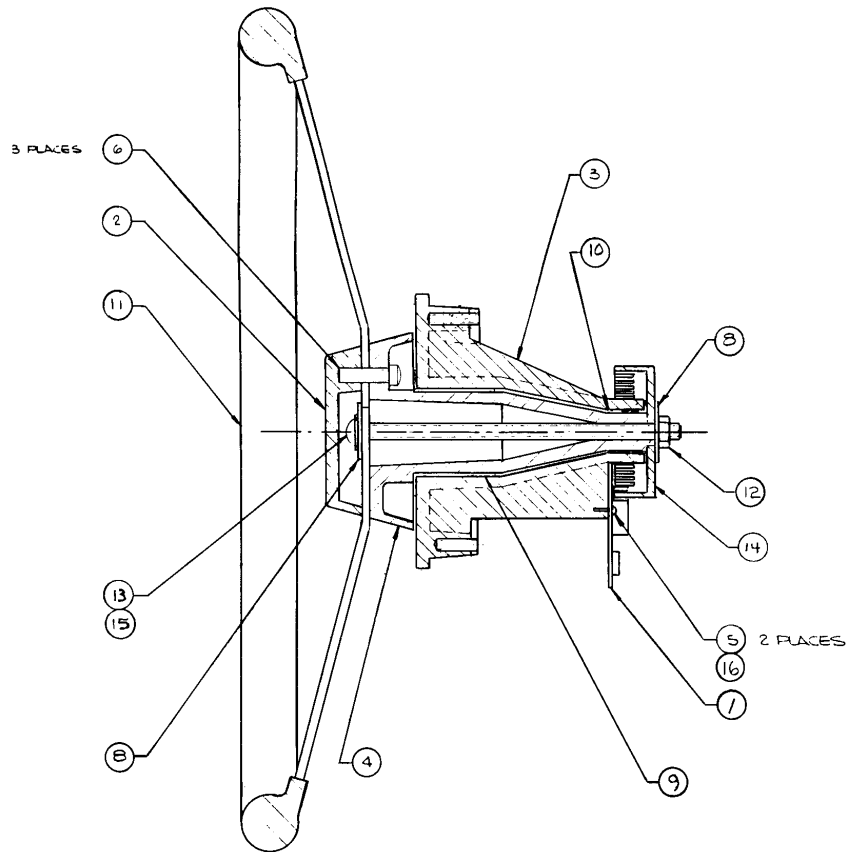

Figure 5-9 Steering Wheel Assembly
A000598-08 T

**Figure 5-9 Steering Wheel Assembly
Parts List**

ITEM	PART NUMBER	QTY.	DESCRIPTION	REFERENCE DESIGNATION
1	A009060-02	1	Steering Printed-Circuit Board Assembly, consisting of the following items:	
1b	10-5392	2	3.9K Ohm, $\pm 5\%$, $\frac{1}{4}W$ Carbon Composition Resistor	R14, 15
1c	10-5331	4	330 Ohm, $\pm 5\%$, $\frac{1}{4}W$ Carbon Composition Resistor	R10-13
1d	10-5471	2	470 Ohm, $\pm 5\%$, $\frac{1}{4}W$ Carbon Composition Resistor	R7, 8
1e	27-250104	1	.1 μ f 25V Radial-Lead Ceramic-Disc Capacitor	C2
1f	29-046	1	10 μ f 20V Axial-Lead Tantalum Capacitor	C1
1g	34-2N3643	2	NPN Silicon Type-2N3643 Transistor	Q1, 2
1h	79-58005	1	10-Position Header Connector	
1i	030369-01	1	Radial Optical Coupler	
2	000599-02	1	Atari-Logo Cover	
3	000605	1	Housing	
4	000606	1	Shaft	
5	85-22F206	2	#2-56 \times 3/8" Pan-Head Phillips Type F Self-Tapping Machine Thread Screw	
6	72-7512	3	#1/4-20 \times 3/4" Fillister-Head Slotted Machine Screw	
8	75-035S	2	#1/4 Flat Wide Zinc-Plated Steel Washer	
9	76-092020	1	1 1/4" Inside Diameter Dual-Shouldered Keyed Nylon Journal Bearing	
10	76-091010	1	5/8" Inside Diameter Dual-Shouldered Keyed Nylon Journal Bearing	
11	78-40104	1	10" Steering Wheel	
12	75-990505S	1	#1/4-20 Self-Locking Prevailing-Torque Shallow-Pattern Steel Hex Nut	
13	72-9580	1	#1/4-20 \times 5" Truss-Head Slotted Machine Screw	
14	000616	1	Hub Light	
15	75-055	1	#1/4 Internal-Tooth Steel Lock Washer	
16	75-042	2	#2 Corrosion-Resistant Steel Split Lock Washer	

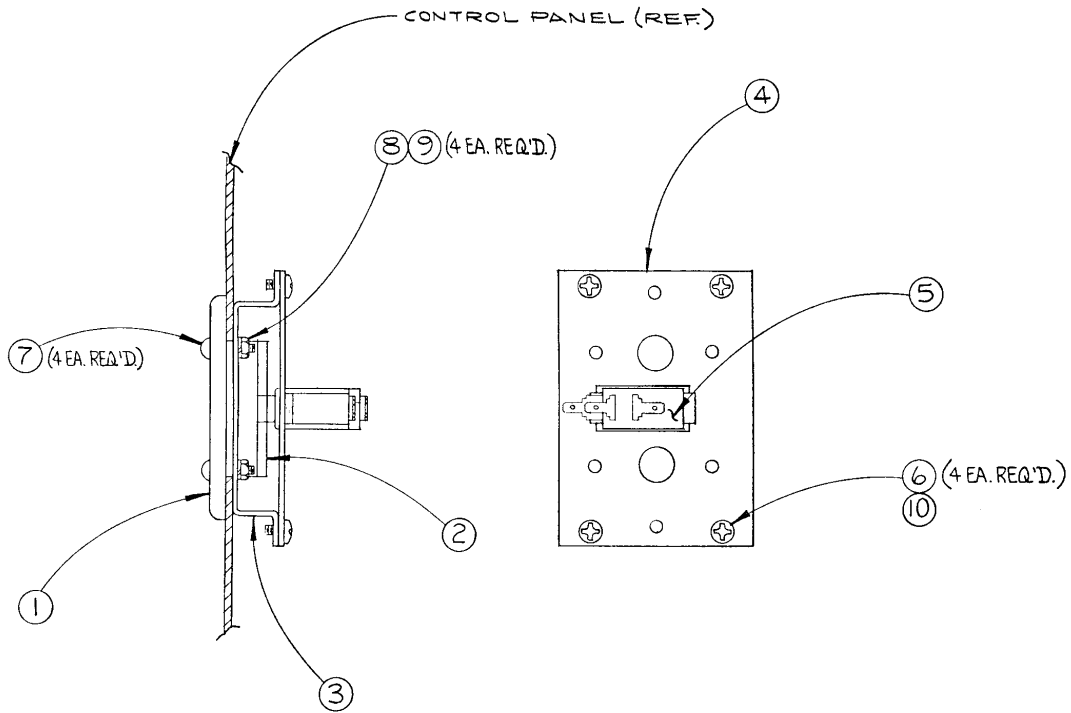

Figure 5-10 Fire Button Assembly
A009338-01 A

Figure 5-10 Fire Button Assembly
Parts List

ITEM	PART NUMBER	QTY.	DESCRIPTION
1	006530-01	1	Bezel
2	006535-01	1	Button
3	006532-01	1	Chassis
4	006533-02	1	Switch Mounting Plate
5	62-020	1	Push-Button Switch, Cherry #E68-50A
6	72-1603	4	#6-32 x 3/16" Pan-Head Cross-Recessed Machine Screw
7	82-8808B	4	#8-32 x 1/2" Allen-Socket Button-Head Hardened-Steel Machine-Thread Screw
8	75-918S	4	#8-32 Standard Hex-Pattern Cadmium-Plated Steel Machine Nut
9	75-048	4	#8 Corrosion-Resistant Steel Split Lock Washer
10	75-046	4	#6 Corrosion-Resistant Steel Split Lock Washer

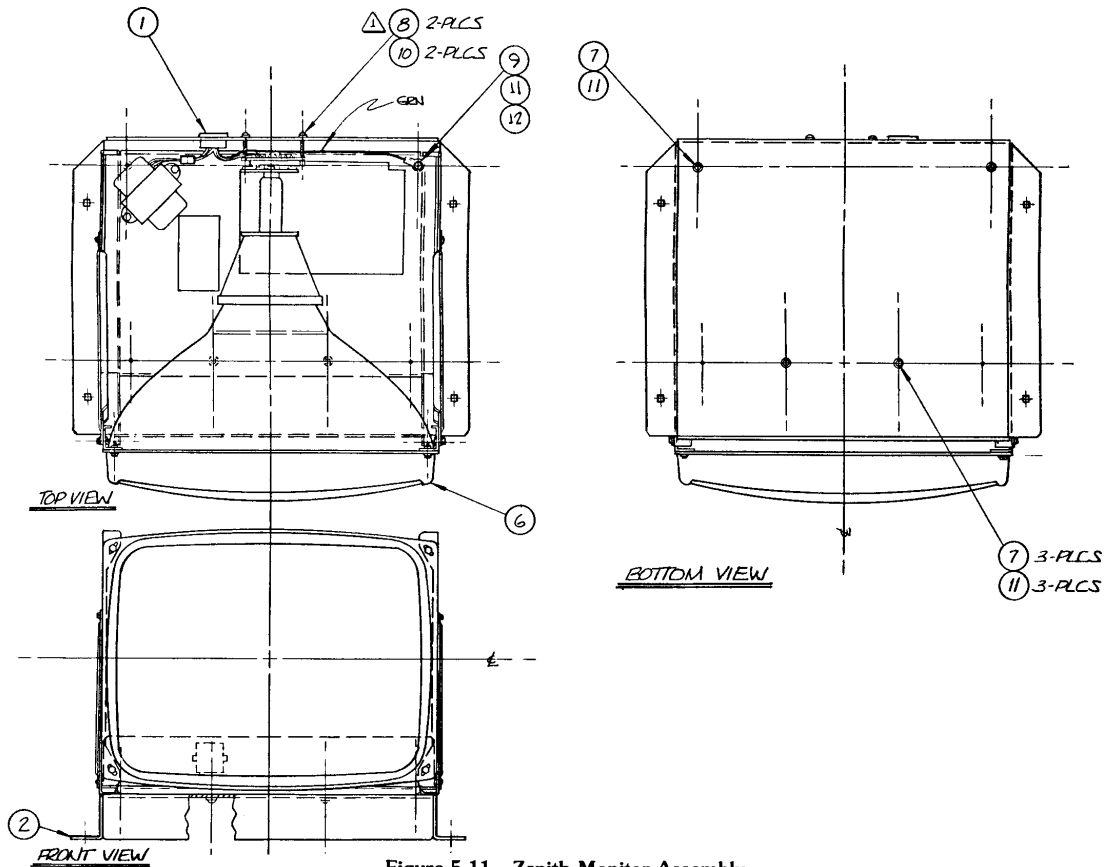

Figure 5-11 Zenith Monitor Assembly
A034608-01 A B C

Figure 5-11 Zenith Monitor Assembly
Parts List

ITEM	PART NUMBER	QTY.	DESCRIPTION
1	A034632-01	1	Zenith Monitor Adapter Harness Assembly
2	034612-01	1	Zenith Monitor Bracket
6	92-041	1	12" Zenith Black-and-White Monitor, Model D12-PF-1
7	72-1612F	4	#6-32 x 3/4" Cross-Recessed Pan-Head Zinc-Plated Steel Machine Screw
8	72-1010F	2	#10-32 x 5/8" Cross-Recessed Pan-Head Zinc-Plated Steel Machine Screw
9	75-016S	1	#6 Flat Plain SAE-Standard Regular-Pattern Steel Washer
	75-050	2	#10 Corrosion-Resistant Steel Split Lock Washer
	75-046	5	#6 Corrosion-Resistant Steel Split Lock Washer
	75-916C	1	#6-32 Standard-Pattern Corrosion-Resistant Steel Hex Machine Nut