

2ND PRINTING—AG

SEGA[®]

SUBROC-3D[™]

OWNER'S MANUAL

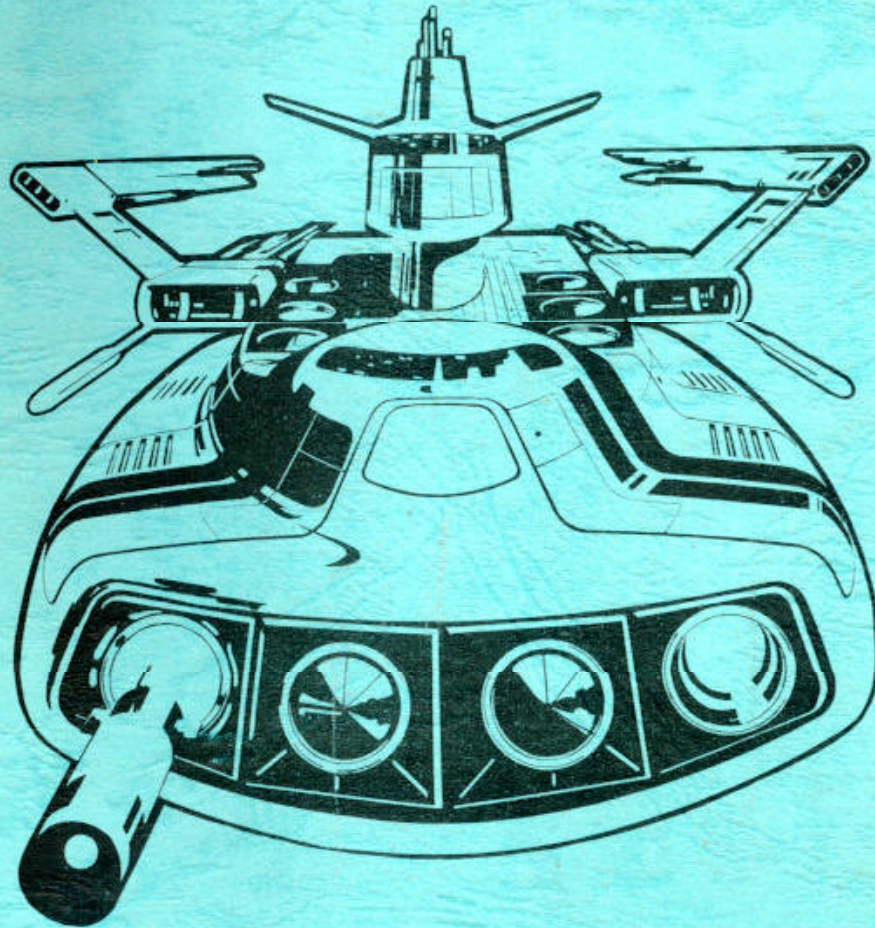

SEGA ENTERPRISES, LTD.

MANUAL NO. 420-5069

SEGA®

SUBROC-3D™

UPRIGHT TYPE

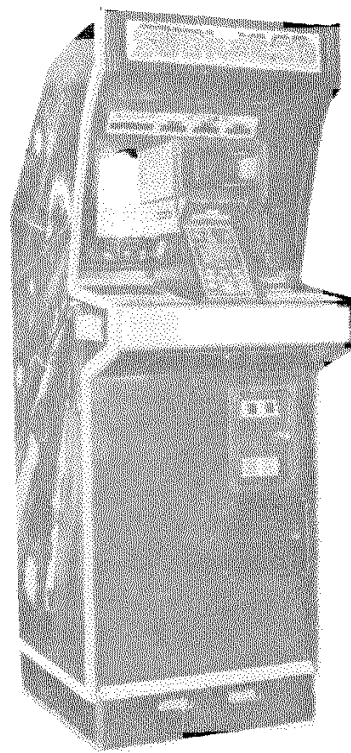

COCKPIT TYPE



Copyright © 1982 by Sega Enterprises, Ltd. All rights reserved.

On Prevention of Illegal Production•Conversion of Games

- For prevention of illegal production and conversion of our machines, a seal showing "ORIGINAL SEAL" is pasted on each of the machines produced by SEGA, or a "LICENCE SEAL" is attached to each IC Board and other kits to be issued by SEGA for production of SEGA machines.
- This is to prevent illegal acts to produce copies of machines and IC Boards without our consent or to produce, convert, or sell machines or IC Boards, and to operate such copies or similar machines or IC Boards.
- You are advised to confirm that SEGA products you operate have the "ORIGINAL SEAL" or "LICENCE SEAL" pasted on or attached to them.

ORIGINAL SEAL
(SAMPLE)



LICENCE SEAL
(SAMPLE)



Explanation of symbols of SEGA products

- The symbol "© SEGA 1982" means that the copyright of the machine is owned by SEGA and was issued in 1982.

C O N T E N T S

SPECIFICATIONS	1
1 INSTALLATION	2
2 CARE IN OPERATION	2
3 OVERVIEW	3
4 GAME CONCEPT	4 . 5
5 GAME THEORY OF OPERATION	6 ~ 8
6 LOGIC BOARD DIAGRAM	9
7 SELF TEST	10~16
8 DIP SWITCH SETTINGS	17
9 ASSY IC BOARD SUBROC-3D	18
10 TROUBLESHOOTING	19
11 SHUTTER SERVICE (BUTTON TYPE)	20 . 21
12 HOW TO EXCHANGE UP/DOWN & FIRE BUTTON	22
13 PARTS CATALOG	23~58
14 SCHEMATIC DIAGRAM	59 . 60
15 LOGIC DIAGRAM (CPU . ROM . SOUND)	61~79

SPECIFICATIONS

UPRIGHT TYPE

Dimensions : 67 cm (W) × 86 cm (d) × 195 cm (h)
Weight : 141 kg
Power Source : AC 100-240V
Power Consumption : 160W
Price per Game : Freely Adjustable
CRT : 20" Color Monitor 100V

COCKPIT TYPE

Dimensions : 67cm(w)×156cm(d)×172cm(h)
Weight : 172kg
Power Source : AC 100-240V
Power Consumption : 160W
Price per Game : Freely Adjustable
CRT : 20" Color Monitor 100V

- Note :
1. Details contained herein may be changed without notice, to effect improvements.
 2. Supplies of spare parts will be maintained at SEGA Enterprises, Ltd., for a period of five (5) years after the date of manufacture of the game concerned.
 3. To enable us to serve our customers more efficiently, we must ask that small orders for spare parts be combined. Minimum orders must be \$50.00 per order.
 4. The following note is included in compliance with FCC rules:
WARNING: This equipment generates, uses and can radiate radio frequency energy and if not installed and used in accordance with the instruction manual, may cause interference to radio communications. As temporarily permitted by regulation, it has not been tested for compliance with the limits for Class A computing devices pursuant to Subpart J of Part 15 FCC Rules, which are designed to provide reasonable protection against interference in which case the user at his own expense will be required to take whatever measures may be required to correct the interference.

1 INSTALLATION

1. As the SEGA SUBROC-3D™ is for "INDOOR USE", do not install it outdoors.
2. When installing it, avoid the following places:
 - Near indoor pools or showers
 - Where leaks exist
 - Under direct sunlight
 - Near heaters or other heat emitting devices
 - Near hazardous items (volatile fluids, gas cylinders etc.)
 - Where vibrations are severe (near construction sites where jack hammers etc. are used)
 - Inclined places
 - Near fire extinguishing equipment
 - Near emergency exits

2 CARE IN OPERATION

1. Inspection
 - Are the IC boards and other connectors firmly connected?
 - Connect ground wire as prescribed. (Never connect to gas pipes, water pipes or electrical conduits)
 - Arrange line cords and ground wires in the aisle so they will not be tripped over.
2. Care in Handling
 - Always turn off the power supply switch before handling.
 - Avoid inserting and pulling the plug in rapid succession.
 - Do not check the IC board circuit with a tester.
3. Care in Usage
 - Care should be taken to avoid dragging or dropping the machine when transporting it, to prevent damage to the CRT.
 - Use fuses of stipulated rating.
 - SUBROC-3D™ is a microprocessor based coin-operated electronic game, that makes extensive use of digital integrated circuitry and television monitor concepts. This manual is designed for the use of maintenance technicians who possess a general working knowledge of solid-state circuitry, and video monitor theory. Any individual NOT knowledgeable in these areas SHOULD NOT attempt repair of the electronic portions of the game.

In addition to this manual and training in electronics, troubleshooting and repair will be facilitated by access to general electronic-type handtools, a multimeter, a 50 or 100 Mhz oscilloscope and a logic probe would be helpful.

3 OVERVIEW

UPRIGHT TYPE

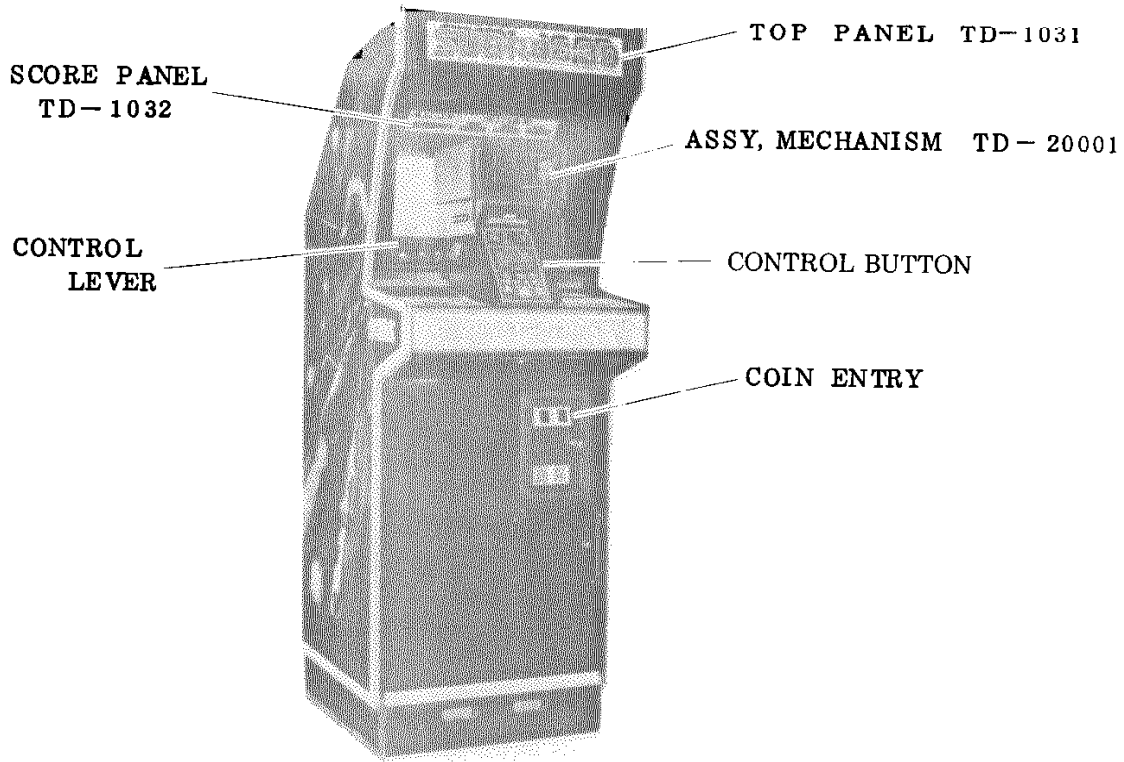

COCKPIT TYPE

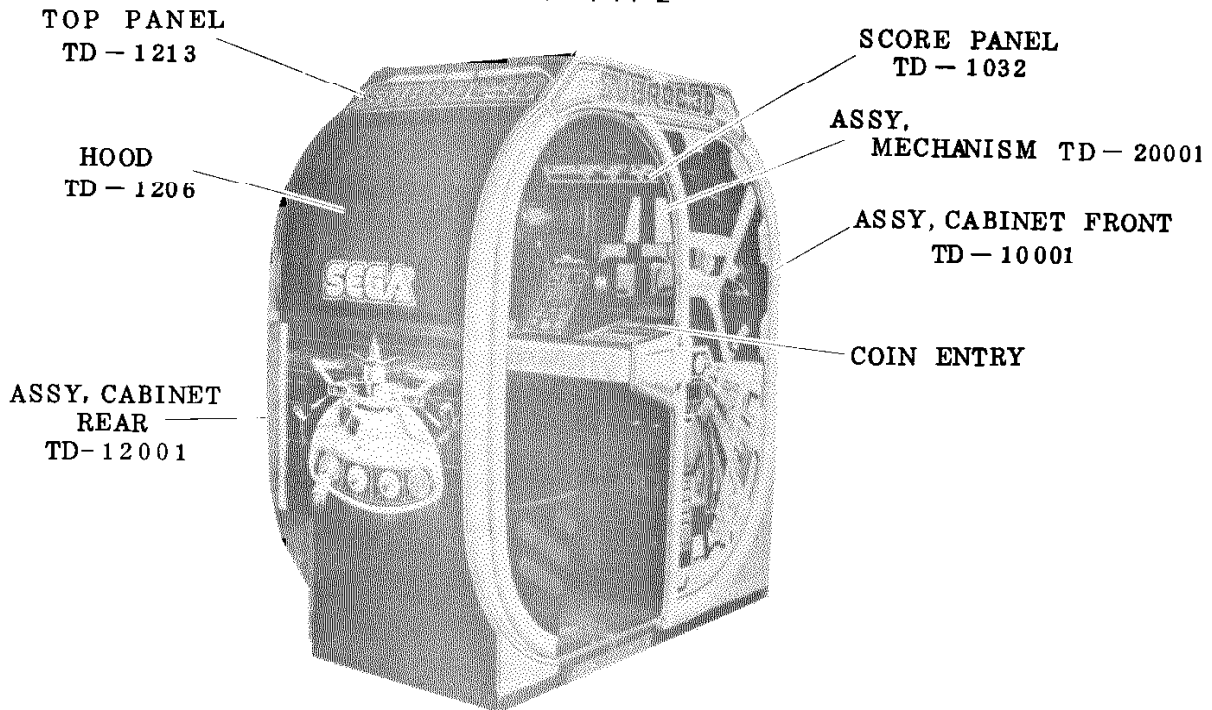

4 GAME CONCEPT

SUBROC-3D is an overwhelming 3-dimensional game, with a dual scene system for battles in the ocean or in space.

The graphics and sound effects are very exciting!

You command a sophisticated craft and by using the elevation controls you can move it up or down so it can be operated under water or in space.

The periscope-type viewer can be moved from side to side, enabling you to attack more enemies.

Press the fire button to shoot down the enemy.

The dynamic stereo sound system creates an amazingly realistic "surround" effect.

Many strangely-shaped crafts, missiles and UFOs suddenly zoom in to attack you; once they are in your sights they can attack you, so shoot first and survive!

The 3-dimensional effect of fast-moving crafts and missiles, combined with the terrifying explosions seemingly right up close to you are truly bewildering.

To destroy the BARRIER guarding the enemy COMMAND SHIP, you must hit it in the very center.

After blowing up the COMMAND SHIP, you proceed to another round. The bonus points remaining will be added to your score.

When you reach "HIGH SCORE" you will get another ship.

In each successive round the score increases by 100 points over the previous round.

Your score and the round are displayed at the top of the screen. Your score and the previous best three scores are displayed over the periscope.

Play ends with the loss of your last ship.

This first-of-its-kind 3-D game, with its speed, excitement and special effects promises to be a really profitable winner from SEGA.

Scoring

Each round 100 points more than in previous round.



300 Points



500 Points



500 Points



1,000 Points



500 Points



250 Points



Mystery NO. of Points
(1,500~ 2,000 Points)



500 Points

Mystery NO. of Points
When you explode all
three (1,500~2,000 Points)



500 Points

COMMAND SHIP

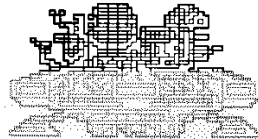

3,000 Points

Each round 1,000 points more than previous round.

5 GAME THEORY OF OPERATION

SUBROC-3D™ is a completely new game concept, combining the best of video-game and electro-mechanical principles. It includes all the basic parts of a video game, such as:

1. Power circuits
2. Input ports
3. Memory circuits
4. Output ports
5. A microprocessor
6. A clock and Video timing circuitry
7. Video and Character-generation circuitry

Next is an explanation of where the items listed above are located in the game.

1. Power circuits (page 4/14 and 6/14 of schematics)

The logic boards of SUBROC-3D require + 5 VDC, + 8 VDC, + 12 VDC and -12 VDC. The 8 VDC voltage provides power for the transistors, while 5 VDC powers the coin counter.

2. Input ports (pages D, 3/14 schematics)

The input ports are the means whereby the player communicates with the computer. Refer to the Maintenance Section for more details.

3. Memory circuits (pages D-1/14, 2/14, 4/14, and 7/14 to 14/14)

There are two types of memory devices: EPROMs AND RAMs. The EPROMs hold the program instructions for the microprocessor, and contain character information. The RAMs act as the video memory.

4. Output ports (pages D-3/14, 4/14, and 5/14 schematics)

The output ports are the means whereby the computer responds to the player's actions. The output ports and the associated ICs are listed in the Maintenance Section.

5. Microprocessor (page D-1/14 schematics)

A Z-80A microprocessor is used as the computer heart of SUBROC-3D. It is IC no. 102 on the CPU board. It controls the movement of data and instructions between memory and the outside world.

6. Clock and Video timing circuitry (page D-1/14 schematics)

This clock circuitry consists of a crystal and IC 79. The clock signal drives the microprocessor and the video timing circuits ICs 48, 58, 59 and 68.

7. Video and Character-generation circuitry (pages D-1/14, 2/14, and 4/14 schematics; see also block diagram of logic board)

The color video patterns are produced on the screen by the video RAM (IC 64), the Address Multiplexers (ICs 74, 75 and 76), Video Memory Controller (ICs 48 and 58), Character Generator (ICs 82 and 83) and the Color PROM (RGB outputs).

The address multiplexers are 74LS157 ICs (ICs 74, 75 and 76), located to the left of the IC 64, on the schematic.

These enable the computer or the video timing system to address the RAMs. This switching between computer and video timing addressing keeps updating or refreshing the information in the RAMs. Of course these changes occur so fast that the video image on the screen changes smoothly. The Video Memory Controller ensures that the switching process does not occur at the same time.

Character generation is handled by a portion of the EPROM which contains the necessary information to produce the various characters of the game. The Color PROM, IC 108, on command from the video memory, generates the pulses which produce the Red, Blue and Green signals for the color monitor.

SHUTTERS FOR 3D

The shutter unit is used to create realistic 3-dimensional pictures. The control of the shutters is such that the left shutter is alternately closed while the right one is open, and vice versa. The integration of the image seen when a shutter is open, the after-image seen when the shutter is closed, and the image seen by the other eye gives a 2-dimensional picture a 3-dimensional effect. Half of the disk-shaped shutter, (which closes off or opens to view for the eye) is painted black. The shutters are driven by a DC motor. The shutter motors and the pictures are synchronized by the signals generated by ICs 115, 116 and 117 on the CPU board.

6 LOGIC BOARD DIAGRAM

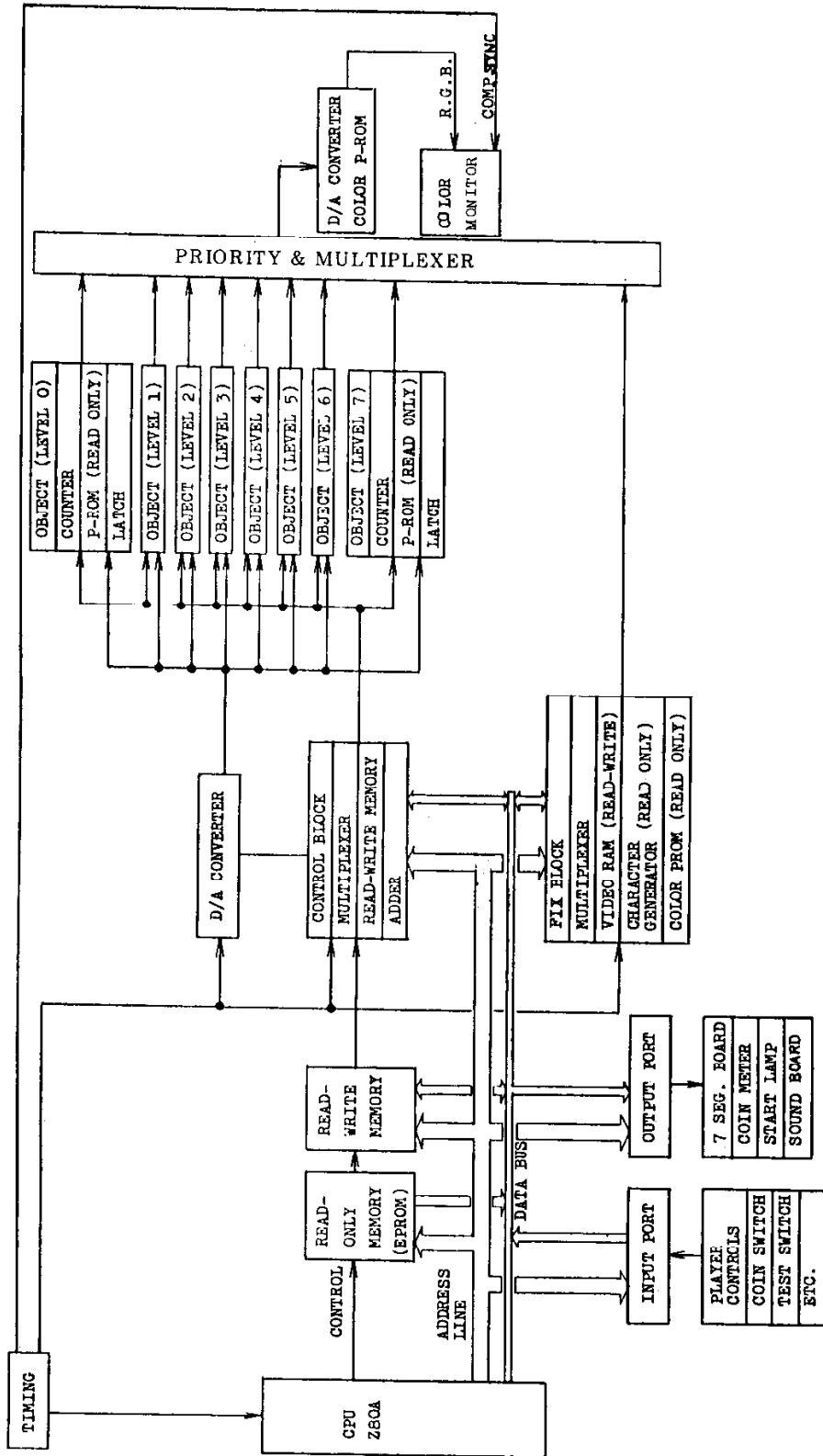

7 SELF TEST

1. General

The main purpose of this test is to check the operation of the game board, to isolate troubles, and for 3-dimensional adjustment of the monitor display.

After checking that each test item is OK by the screen display or sound, press the STEP button (START BUTTON) to advance to the next test item.

2. Test Item Sequence

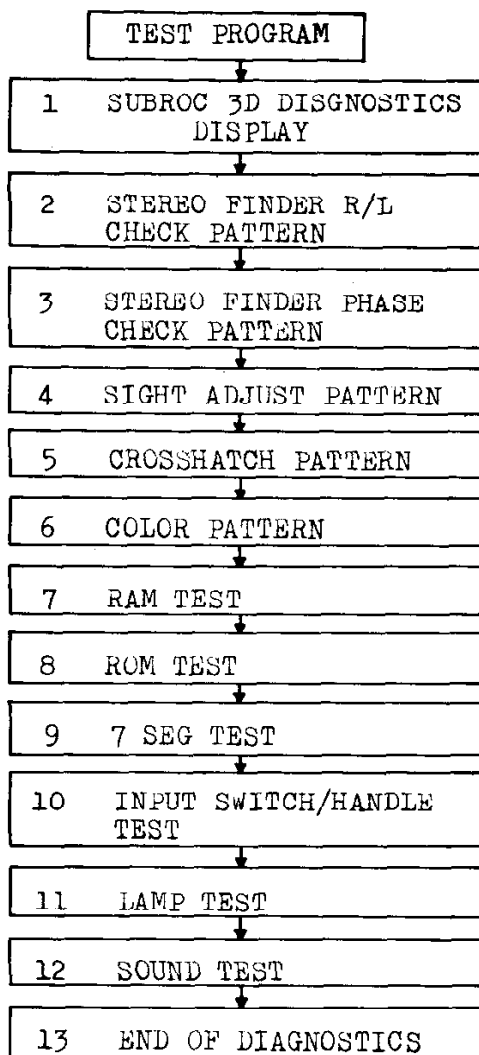

3. Test Items and Contents

Screen display

① Self test start

SUBROC 3D DIAGNOSTICS is displayed on the screen.

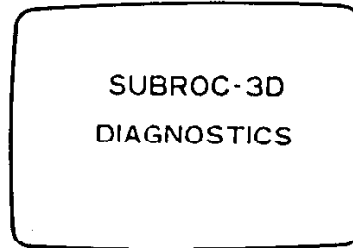

② STEREO FINDER R/L CHECK PATTERN

Shutter (834-0346) check.

The shutter is operating normally if you can see the left arrow with your left eye and the right arrow with your right eye.

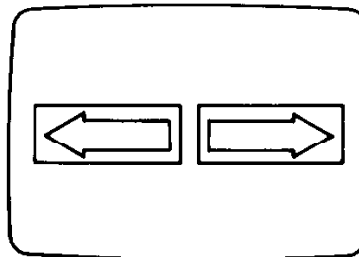

③ STEREO FINDER PHASE CHECK PATTERN

Shutter check.

The shutter is operating normally if the two As, Bs, Cs, etc, look like one A, B, C, etc.

when you view them with both eyes.

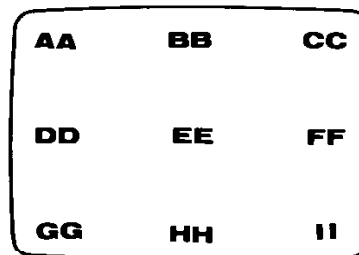

④ SIGHT ADJUST PATTERN

Sight unit (TD-1020 UPRIGHT,
TD-1058 COCKPIT) adjustment.
Two crosses (+ +) are displayed
in the center of the screen.
(Open the back door and turn
the two adjustment screws on the
sight unit by hand so that
the cross on the screen matches
the center of the aim.)

Screen display

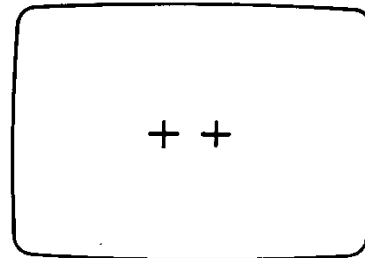

⑤ CROSSHATCH PATTERN

A crosshatch pattern appears on
the screen. Use this pattern for
monitor screen adjustment.
For monitor adjustment, refer to
the Display Manual (420-5028).
(After this item, the shutter unit
stops operation.)

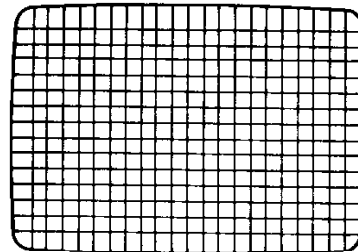

⑥ COLOR PATTERN

Ten strips of colors appear on the
screen.

- ① Dark blue
- ② Blue
- ③ Light blue
- ④ Orange
- ⑤ Yellow
- ⑥ Red
- ⑦ White
- ⑧ Dark gray
- ⑨ Gray
- ⑩ Magenta

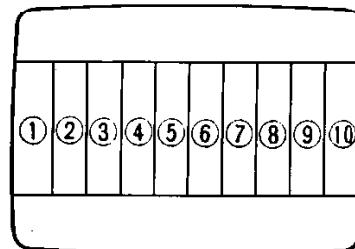

Screen display

⑦ RAM TEST

"GOOD" means that RAM is operating normally. When "BAD" is displayed, IC 64 RAM is faulty.

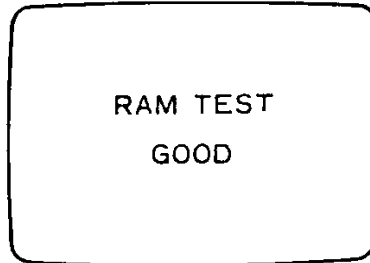

⑧ ROM TEST

"GOOD" means that ROM is operating normally.

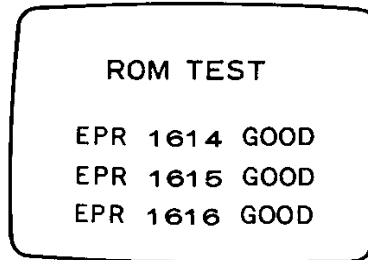

⑨ 7 SEG TEST

The player's and best 3 scores display segment check.

First, numbers 543210 are displayed.

When the START button is pressed,

each of these numbers changes

000000 → 111111 → ... → 999999.

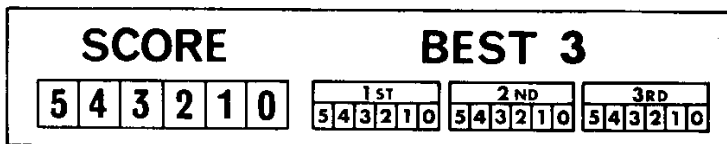
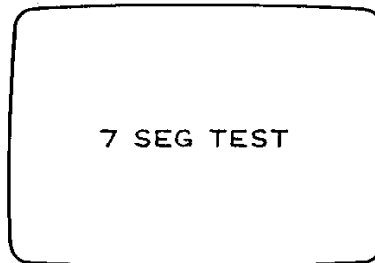

⑩ INPUT SWITCH

The ON/OFF state of each switch is displayed on the screen.

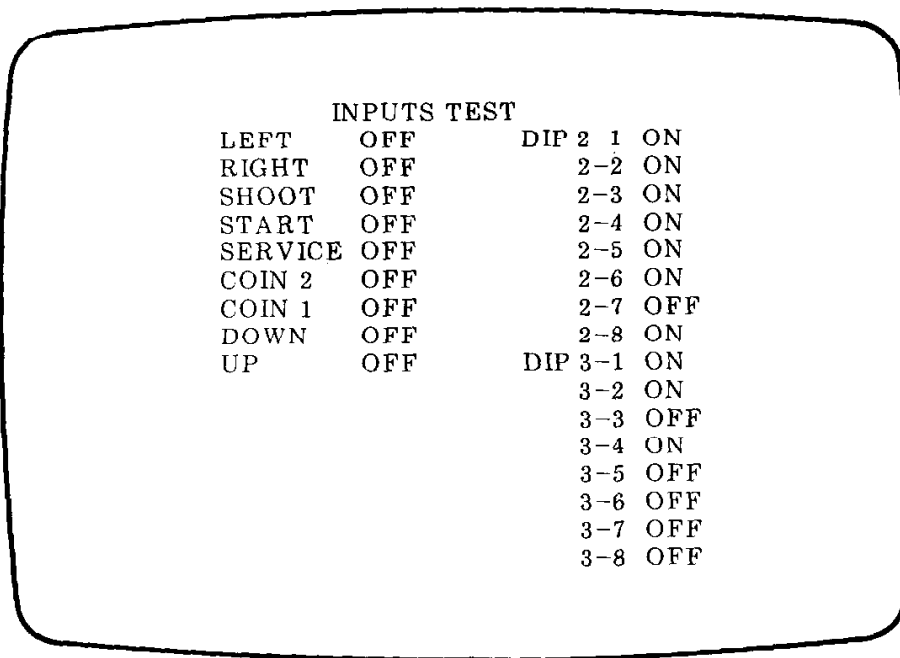

For the setting method , see page 17.

⑪ LAMP TEST

START button lamp check.

Press the START button repeatedly and check that it blinks.

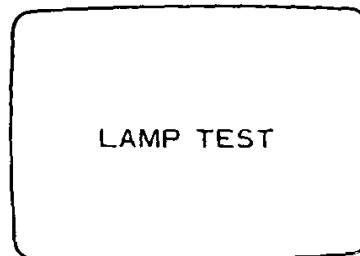

Screen display

⑫ SOUND TEST

12 kinds of sound can be checked here. (Press the SELF TEST button to step to the next sound. To listen to the same sound again, press the START button.)

- ① ENEMY MISSILE
- ② ENEMY TORPEDO
- ③ ENEMY FIGHTER
- ④ EXPL IN SKY (explosion in the sky)
- ⑤ EXPL ON SEA (explosion on the sea)
- ⑥ MISSILE SHOOT
- ⑦ TORPEDO SHOOT
- ⑧ MY SHIP EXPL
- ⑨ PROLOG SOUND
- ⑩ PROLOG OFF
- ⑪ ALARM 0
- ⑫ ALARM 1

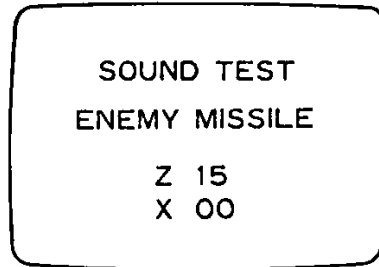

. The value after Z indicates the sound volume. 15 is the minimum and 00 is the maximum.

To change the sound volume, press the SHOOT button.

. The value after X indicates the balance between the right and left speakers.

(00 is the left speaker only and 06 is the right speaker only. Change the value by operating the control lever.)

Screen display

⑬ END OF DIAGNOSTICS

The self test ends here. To return to the normal screen, press the SELF TEST button once. To repeat the self test, press the button twice.

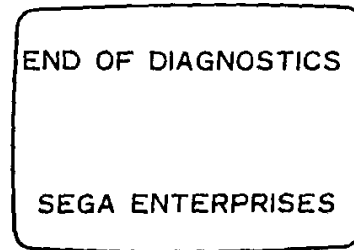

Of the above 13 self test items, the shutter motor operates during items

① to ④. (The shutter motor does not operate when bit 7 of DIP SW #3 is ON. In this case, only the left arrow is displayed on the screen in item ②.)

The shutter motor is stopped during items ⑤ to ⑬ (regardless of ON/OFF state of DIP SW #3 bit 7).

8 DIP SWITCH SETTINGS

DIP SWITCH NO. 2

	OPTION	SWITCH SETTINGS ON 8-TOGGLE DIP-SW.							
		1	2	3	4	5	6	7	8
COIN SW. #1	1 COIN 1 CREDIT	ON	ON	ON					
	1 COIN 2 CREDITS	OFF	ON	ON					
	1 COIN 3 CREDITS	ON	OFF	ON					
	1 COIN 6 CREDITS	OFF	OFF	ON					
	2 COINS 1 CREDIT	ON	ON	OFF					
	3 COINS 1 CREDIT	OFF	ON	OFF					
COIN SW. #2	4 COINS 1 CREDIT	ON	OFF	OFF					
	5 COINS 1 CREDIT	OFF	OFF	OFF					
	1 COIN 1 CREDIT				ON	ON	ON		
	1 COIN 2 CREDITS				OFF	ON	ON		
	1 COIN 3 CREDITS				ON	OFF	ON		
PLAYER SHIP	1 COIN 6 CREDITS				OFF	OFF	ON		
	2 SHIPS							ON	ON
	3 SHIPS							OFF	ON
	4 SHIPS							ON	OFF
	5 SHIPS							OFF	OFF

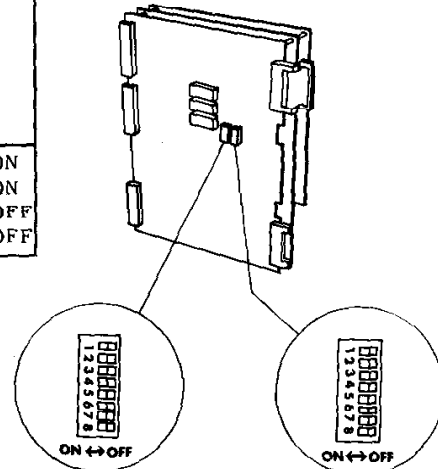

DIP SWITCH NO. 3

DIP SW NO. 2

DIP SW NO. 3

OPTION	SWITCH SETTINGS ON 8-TOGGLE DIP-SW.							
	1	2	3	4	5	6	7	8
EXTRA 20,000PT.	ON	ON						
SHIP 40,000PT.	OFF	ON						
SCORE 60,000PT.	ON	OFF						
80,000PT.	OFF	OFF						
INITIAL INPUT DISABLE			ON					
ENABLE			OFF					
DIFFICULTY DIFFICULT				ON				
NORMAL				OFF				
FREE PLAY					ON			
NORMAL PLAY					OFF			
STOP MOTION *						ON		
NORMAL MOTION						OFF		
MONO SCREEN							ON	
STEREO SCREEN							OFF	
ENDLESS GAME								ON
NORMAL GAME								OFF

* : Push START button to stop motion.

9 ASSY IC BOARD SUBROC-3D

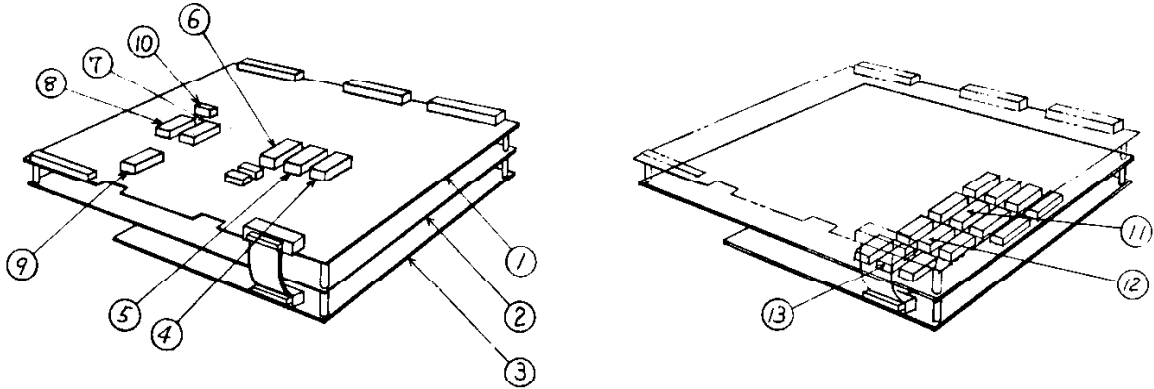

ASSY IC BOARD		834-0357		
Description				
① IC board CPU	834-0358			
② IC board PROM	834-5058			
③ Sound board	834-0246			
④ EPR-	1614			
⑤ EPR-	1615			
⑥ EPR-	1616			
⑦ EPR-	1617			
⑧ EPR-	1618			
⑨ PR-	1619			
⑩ PR-	1620			
⑪ EPR-	1666			
⑫ EPR-	1665			
⑬ EPR-	1664			

10 TROUBLE SHOOTING ①

When it is believed that trouble has developed, always confirm the following items.

- Is the fuse intact ? (Always use a fuse of the designated rating). If the new fuse burns out, this will indicate that another component is defective.
- Are there any poor connections (connectors) or open circuits. Special care must be taken to ensure connectors are firmly inserted ; trouble due to faulty contacts can be considered from various sources.

Note: Always turn off the power when inserting or removing the connectors.

- There will be times when a normal picture will not appear when the power supply switch is turned on. As this may sometimes be corrected by a setting of the control circuit, turn power supply switch on and off several times.
- When testing meters, switches etc. with a tester, always first pull the IC board connectors.

11 SHUTTER SERVICE (BUTTON TYPE)

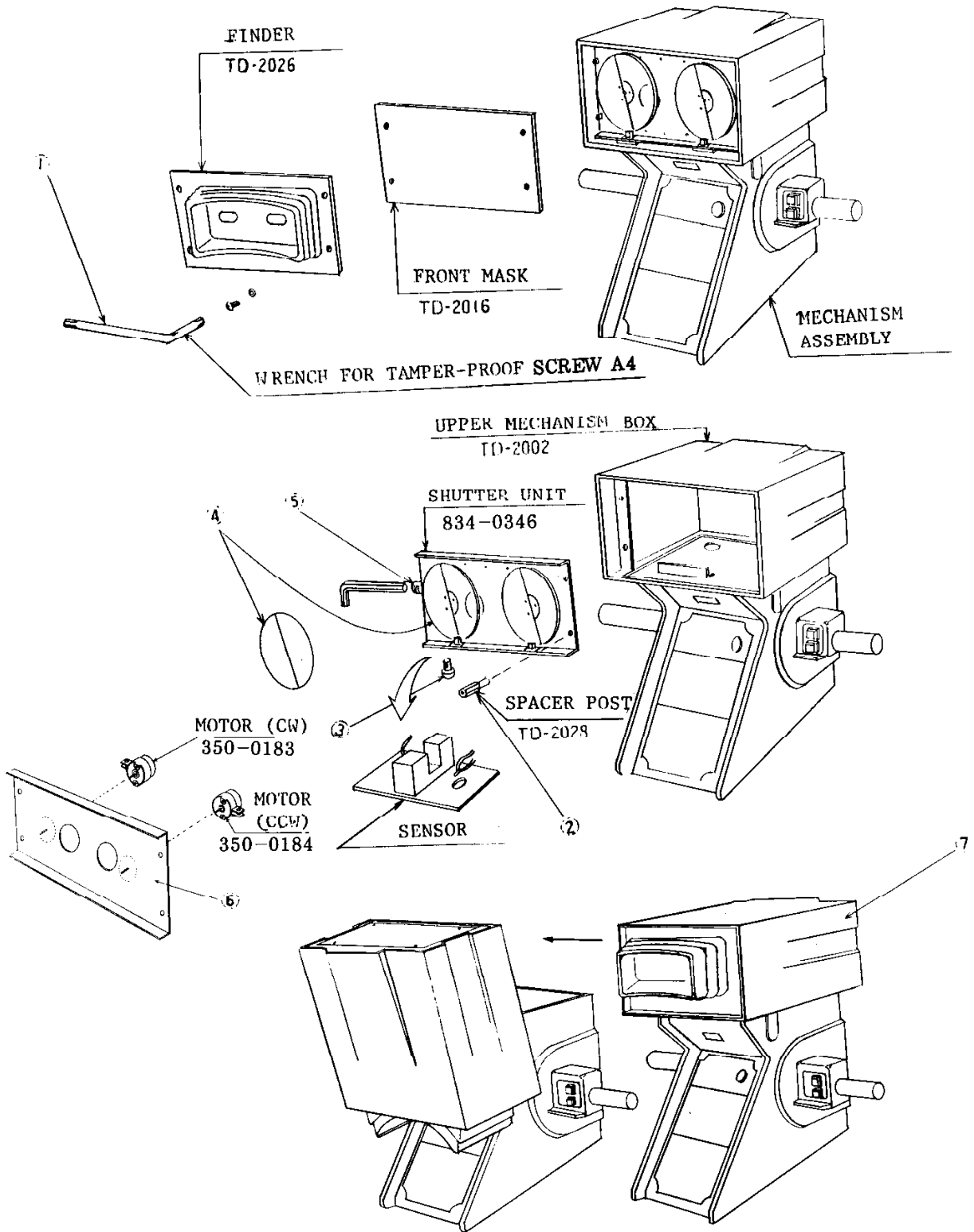

SHUTTER SERVICE (BUTTON TYPE)

Time to replace motors

Motors must be replaced if the results as explained cannot be obtained by self tests ① to ④. Replace the right and left motors at the same time.

How to replace motors

- ① With the attached wrench for tamper-proof screws, remove the four screws holding the finder TD-2026 and the front mask TD-2016 together.
- ② Remove the four spacer posts, and take the shutter out of the upper mechanism box.
- ③ Remove the two sensors fixed with two screws each.
- ④ Remove the two discs fixed with three screws each.
- ⑤ Remove the set screws and the flanges.
- ⑥ Remove the two screws and replace each motor.

Cautions on reassembly

Note that the motor on your left is 350-0183 (CW) and the motor on your right is 350-0184 (CCW) when replacing motors.

When installing the sensors in procedure ③ above, set the sensors so that the discs fit in the center of the concaves of the sensors. The periscope part can be pushed down as shown in ⑦ in the next figure during reassembly.

12 HOW TO EXCHANGE UP/DOWN & FIRE BUTTON

With the attached wrench (SGM-3219 Driver or SGM-3152 wrench) for tamper-proof screw (M5), remove the 2 screws holding the casting

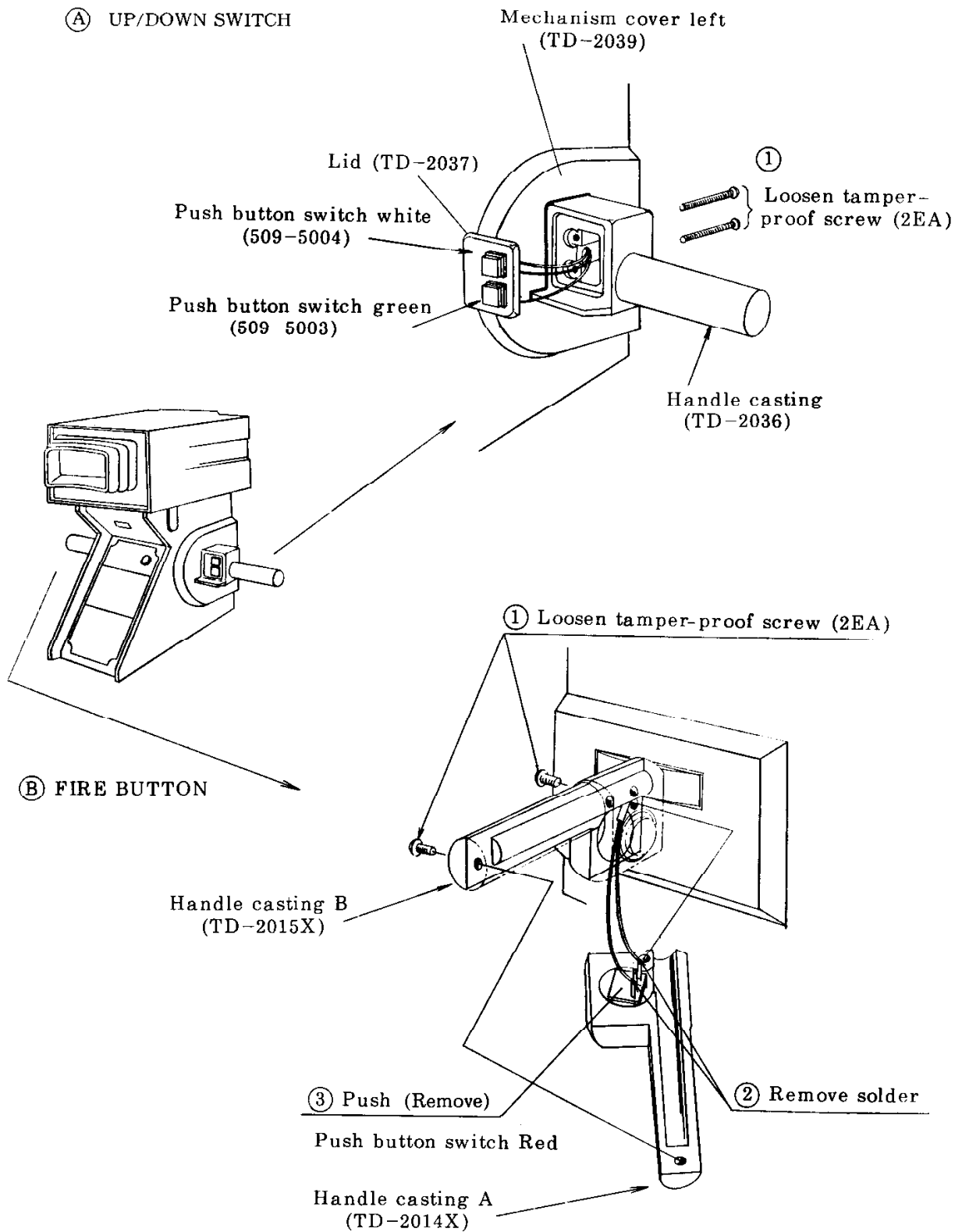

13 PARTS CATALOG

TOP ASSY UPRIGHT

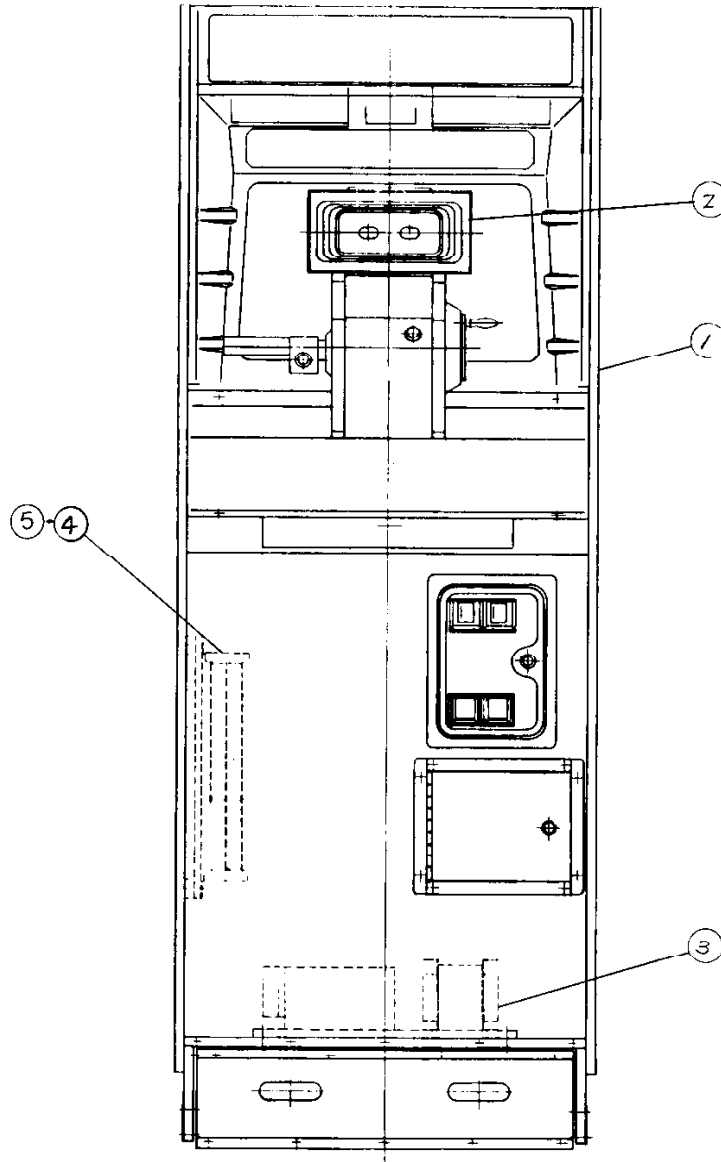

ITEM NO.	PART NO.	DESCRIPTION
1	TD-1000	ASSY CABINET (See page 24 for details)
2	TD-20001	ASSY MECHANISM (See page 31 for details)
3	TD-4000	ASSY POWER SUPPLY (See page 35 for details)
4	834-0357	ASSY IC BOARD SUBROC-3D EXPORT
	834-0358	Assy IC board SUBROC-3D CPU USA
	834-5058	Assy IC board SUBROC-3D PROM USA
	834-0246	Assy sound board SUBROC-3D
5	834-5060	ASSY EMI FILTER BOARD (See page 43 for details)

UPRIGHT TYPE

ASSY CABINET ACCESSORY

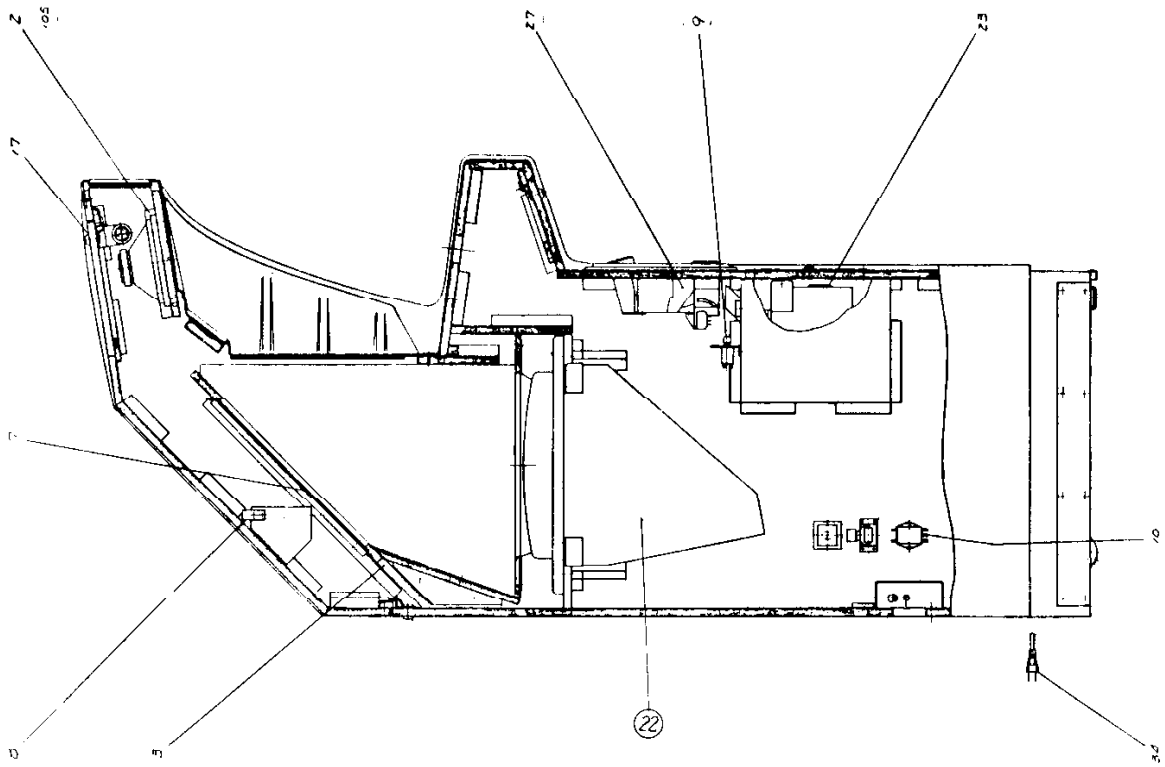
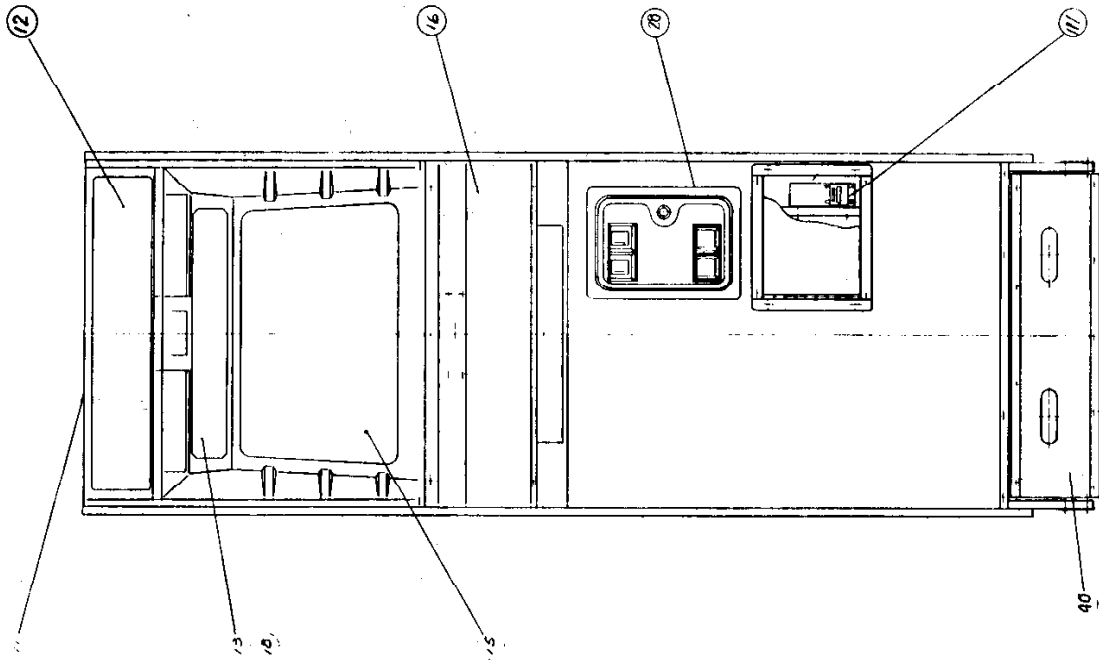

UPRIGHT TYPE

ASSY CABINET ACCESSORY

ITEM NO.	PART NO.	DESCRIPTION
2	TD-1005	Speaker board
3	TD-1006	Mirror board
7	TD-1016	Half mirror
8	TD-1020	SIGHT UNIT (See page 27 for details)
9	TD-1028	CONTROL UNIT (See page 30 for details)
11	TD-1030	Front mask
12	TD-1031	Top panel SUBROC-3D
13	TD-1032	Score panel
15	TD-1034	Front window
16	TD-1035X	Front panel
17	TD-1036	SERVICE DOOR ROOF
	214-0009	Socket
	390-0031	Fluorescent light 15W
18	TD-1100	ASSY SCORE BOARD (See page 28 for details)
19	AB-1166Z	TV mask T8 20
22	200-0039	Assy color display 100V
23	TA-1075X	Cash box
27	220-0084	Coin chute rejr 25¢
28	SGM-2972-2	Assy coin chute door USA 25¢ Twin (See page 26 for details)
34	600-0110	Assy cable & plug W/Earth
40	TD-1011	Step
105	130-0018	Speaker 16cm 8Ω
110	601-0429	Noise filter AC 250V 4A
111	220-0213	Coin counter 6 digits DC 5V

Please refer to the separate book called the
 "DISPLAY MANUAL" concerning the color monitor.

UPRIGHT TYPE

ASSY COIN CHUTE DOOR (SGM-2972-2)

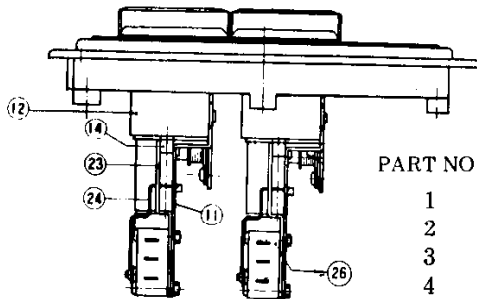
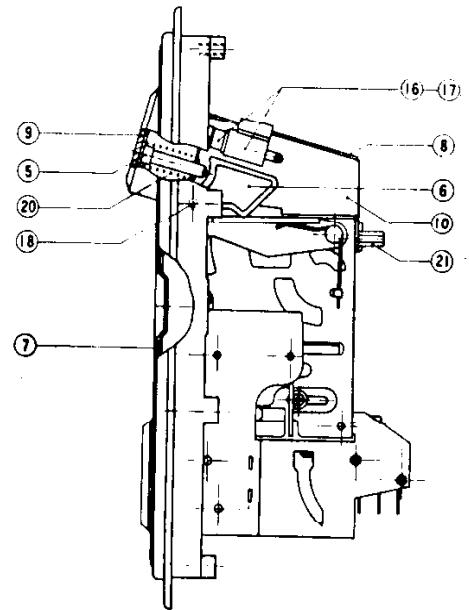
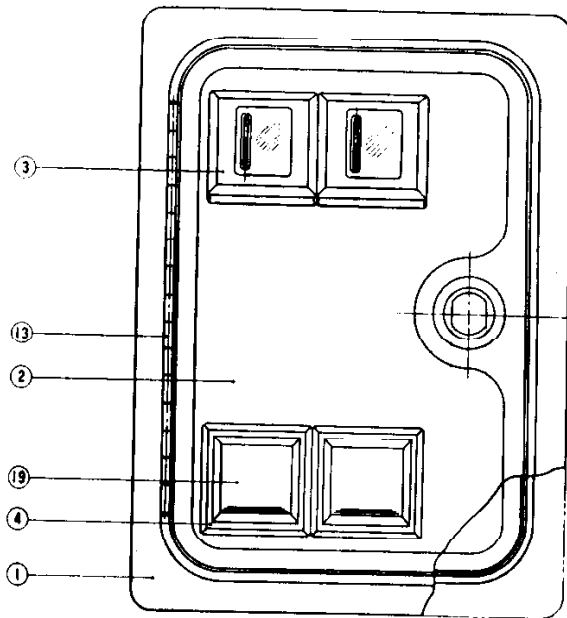

PART NO.	DESCRIPTION	
1	Service door frame B	(ADDS-1001)
2	Service door B W	(ADDS-1002)
3	Coin entry base	(ADDS-1003)
4	Cancel cup base	(ADDS-1004)
5	Coin entry USA 25¢	(ADDS-1005-1)
6	Cancel link	(ADDS-1006)
7	Sub-plate	(ADDS-1007)
8	Entry chute left	(ADDS-1008)
9	Gauge plate	(ADDS-1009)
10	Entry chute right	(ADDS-1010)
11	Cancel box right	(ADDS-1011)
12	Cancel box left	(ADDS-1012)
13	Hinge	(ADDS-1013)
14	Inner guide	(ADDS-1014)
16	Bulb, 12V	(ADDS-1016)
17	Bulb socket	(ADDS-1017)
18	Cancel lever pin	(ADDS-1018)
19	Cancel cover	(ADDS-1019)
20	Spring	(ADDS-1020)
21	Selector stop screw	(ADDS-1021)
23	Chute	(ADDS-1023)
24	Actuator	(ADDS-1024)
26	Micro switch	(ADDS-1026)

UPRIGHT TYPE

SIGHT UNIT (TD-1020)

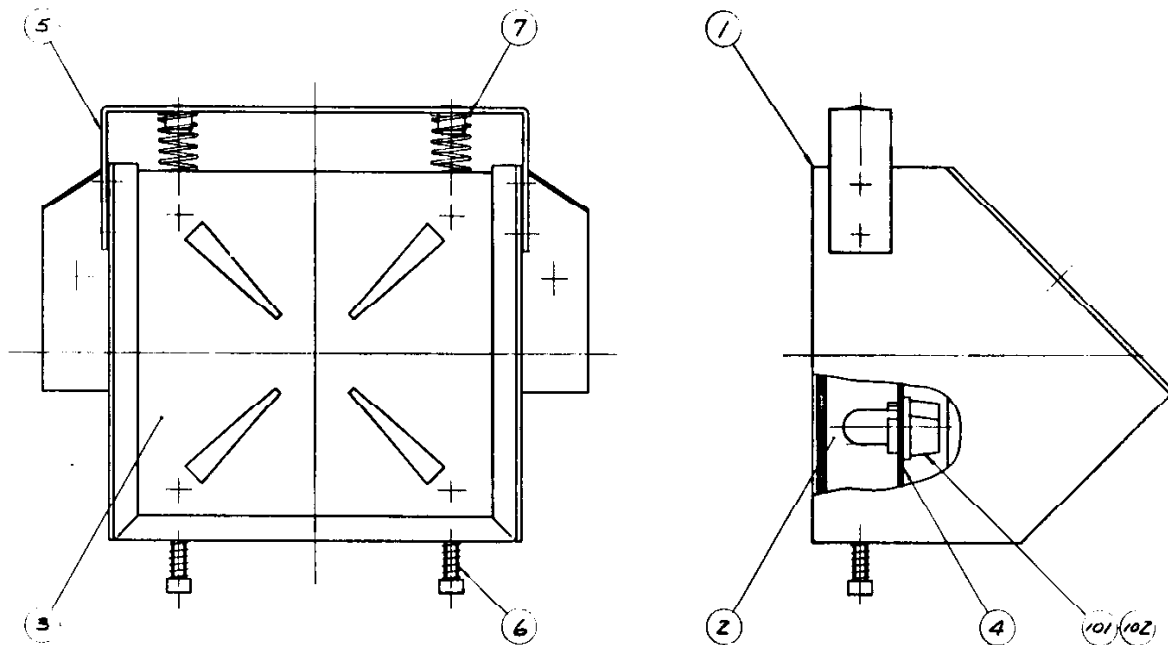

ITEM NO.	PART NO.	DESCRIPTION
1	TD-1021	Frame
2	TD-1022	Lamp board
3	TD-1023	Sight plate
4	TD-1024	Lamp holder board
5	TD-1025	Bracket
6	TD-1026	Compression spring
7	TD-1027	Compression spring
101	214-0081	Assy wedge base socket
102	390-0116	Lamp wedge base type 14V 0.24V
	SGB-3118-16	Wire harness LP

UPRIGHT TYPE

ASSY SCORE BOARD (TD-1100)

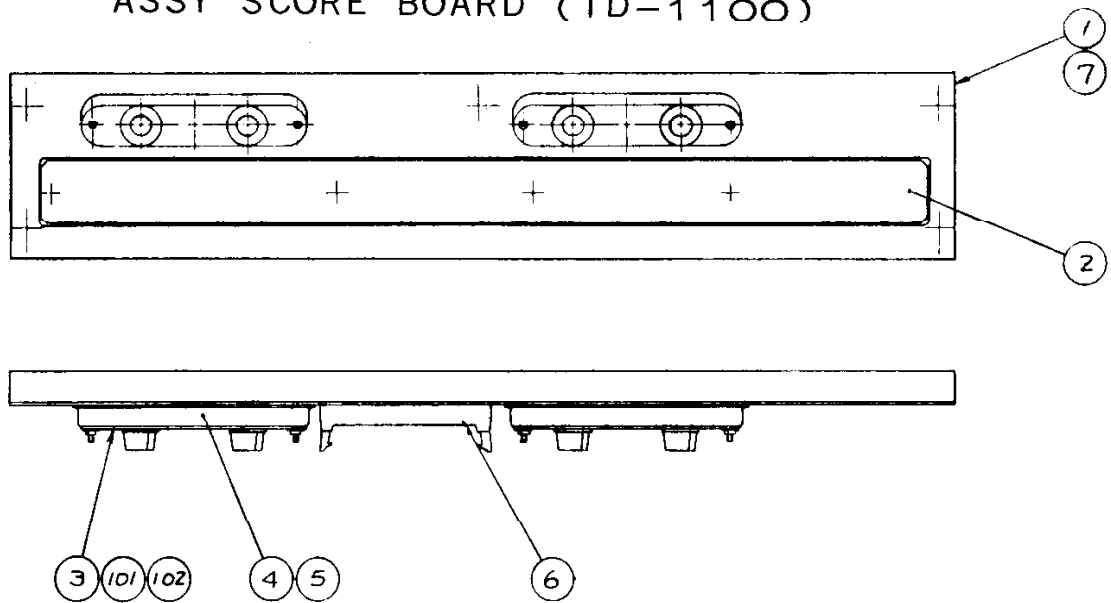

ITEM NO.	PART NO.	DESCRIPTION
1	TD-1101	Score board
2	TD-1102	Mask score
3	TD-1103	Lamp holder board
4	TD-1104	Lamp cover
5	SA 0004	Spacer tube 10
6	834-0305	ASSY LED 7 SEG BOARD (See page 29 for details)
7	SGB-3118-17	Wire harn score lamp
101	390-0116	Lamp wedge base type 14V 0.24A
102	214-0018	Assy wedge base socket

UPRIGHT & COCKPIT TYPE

ASSY LED 7 SEG BOARD (834-O305)

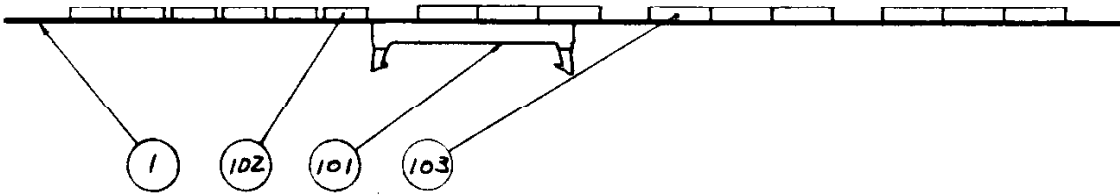
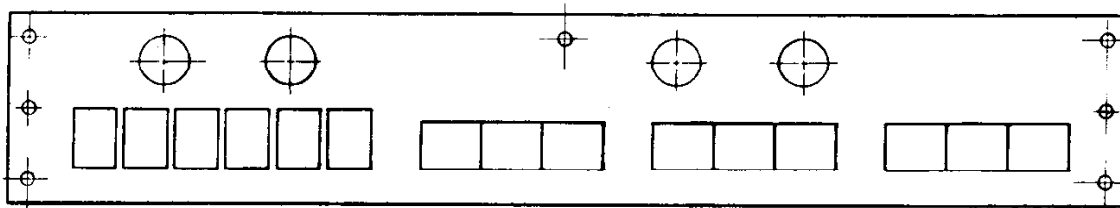

ITEM NO.	PART NO.	DESCRIPTION
1	171-0090	Printed board LED 7 seg
101	212-0120	Conn M50 pin
102	390-0108	LED TLR306 7 seg Red
103	390-0123	LED 2DGT Red TLR 325

UPRIGHT & COCKPIT TYPE

CONTROL UNIT (TD-1028)

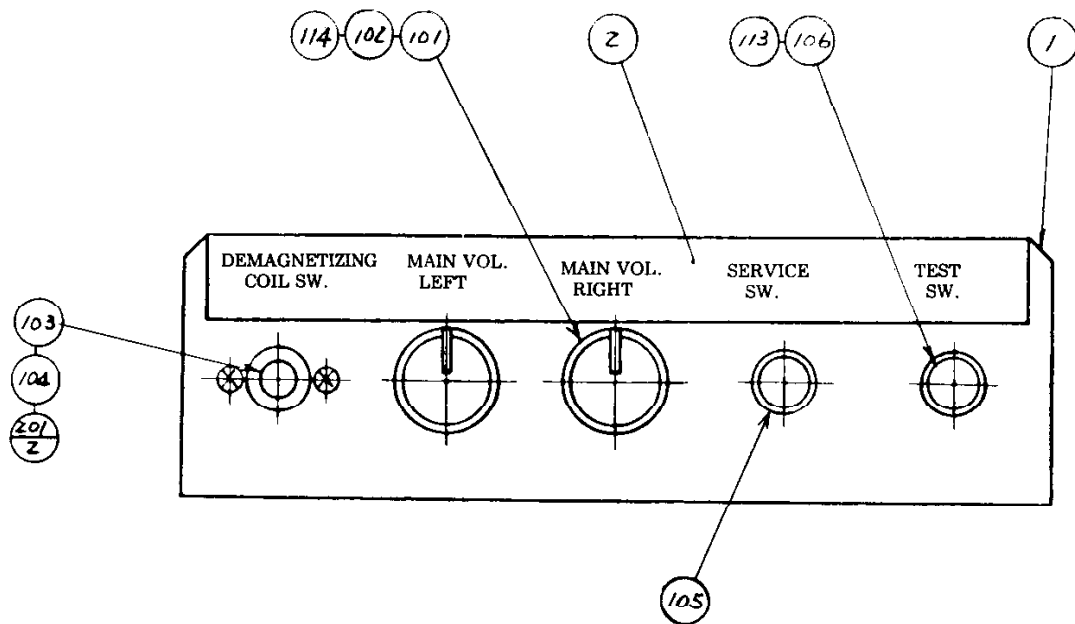

ITEM NO.	PART NO.	DESCRIPTION
1	TB-1021X	Control bracket
2	83824	Sticker control instructions
	SGB-3118-5	Wire harness volume
	SGB-3118-10	Wire harness service test SW
	SGB-3118-12	Wire harness Demagnetizing SW
101	601-0042	Knob 22 mm
102	220-0111	Volume control B-25K ohm
103	601-0444	C & R combination element
104	240-0105	Push button switch 1M
105	240-0106	Push button ivory 8 ϕ
106	509-0113	Push button switch 2T
	211-0085	Conn plug AMP 2P brown
	211-0098	Conn plug AMP 3P orange
	211-0100	Conn plug AMP 4P red
	211-0122	Conn cap AMP 4P orange
	211-0041	Conn pin AMP
	211-0042	Conn socket AMP
113	509-0049	Switch stopper 12 ϕ
114	470-0332	Res 3.3K ohm 1/4W

UPRIGHT & COCKPIT TYPE

ASSY MECHANISM (TD-20001)
(BUTTON TYPE)

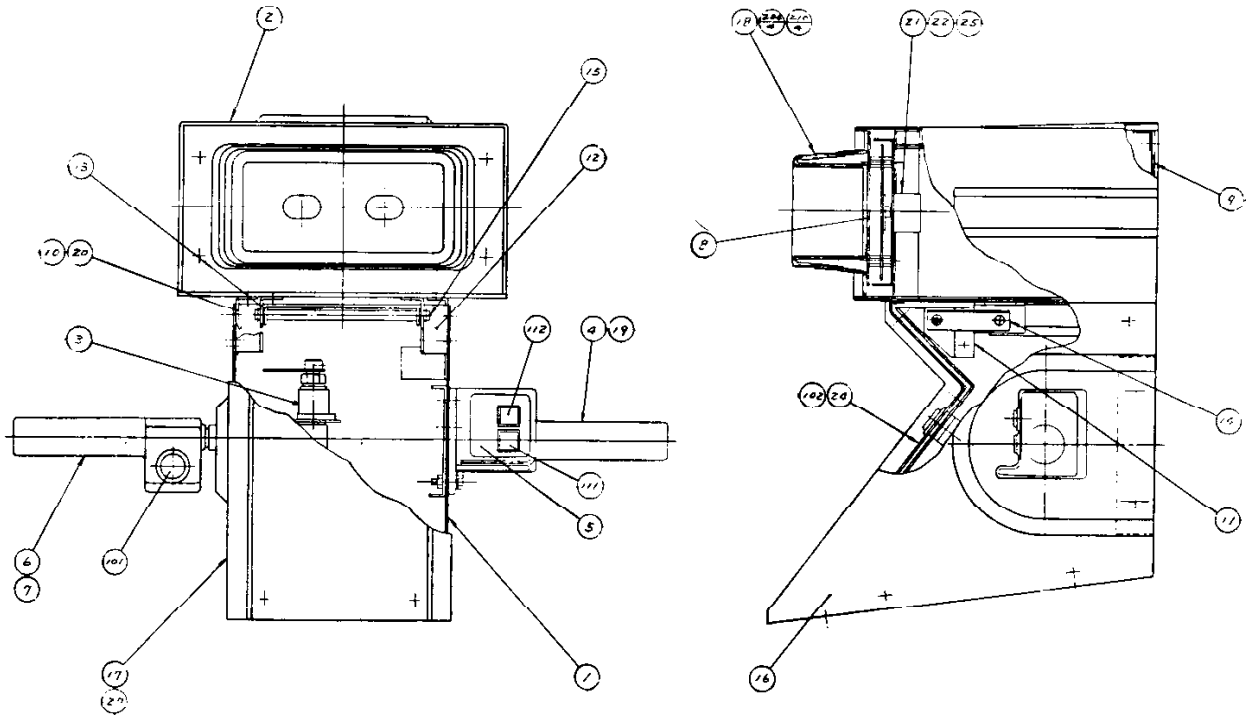

ITEM NO.	PART NO.	DESCRIPTION
	TD-2056	ASSY HANDLE MECHANISM EXPORT (See pages 34 for details)
	TD-2036	Handle casting
	TD-2037	Lid
	TD-2014X	Handle casting A
	TD-2015X	Handle casting B
	TD-2016	Mask front
	TD-2017	Mask back
	TD-2055	Guide bracket left
	TD-2019	Hold bracket right
	TD-2020	Hold bracket left
	TD-2022	Joint
	TD-2023	Shaft
	TD-2039	Mechanism cover left
	TD-2054	Mechanism cover right
	TD-2026	Finder
	TD-2038	Handle support bracket
	TD-2053	Guide bracket right
	834-0346	Assy shutter for 3D (See page 32 for details)
	TD-2031	Motor bracket
	TD-2058	Information plate English
	TD-2059	Information plate USA
25	TD-2028	Spacer post
26	TD-2041	Spacer left
27	TD-2042	Spacer right
101	509-0160	Push button switch 1T Red
102	509-0161	Push button switch 1T Yellow
111	509-5003	Push button switch 1T Green
112	509-5004	Push button switch 1T White
	SPARE PARTS	
	350-0183	Motor DC 6V CW 4000HR
	350-0184	Motor DC 6V CCW 4000HR

UPRIGHT & COCKPIT TYPE

ASSY SHUTTER FOR 3D (834-0346)

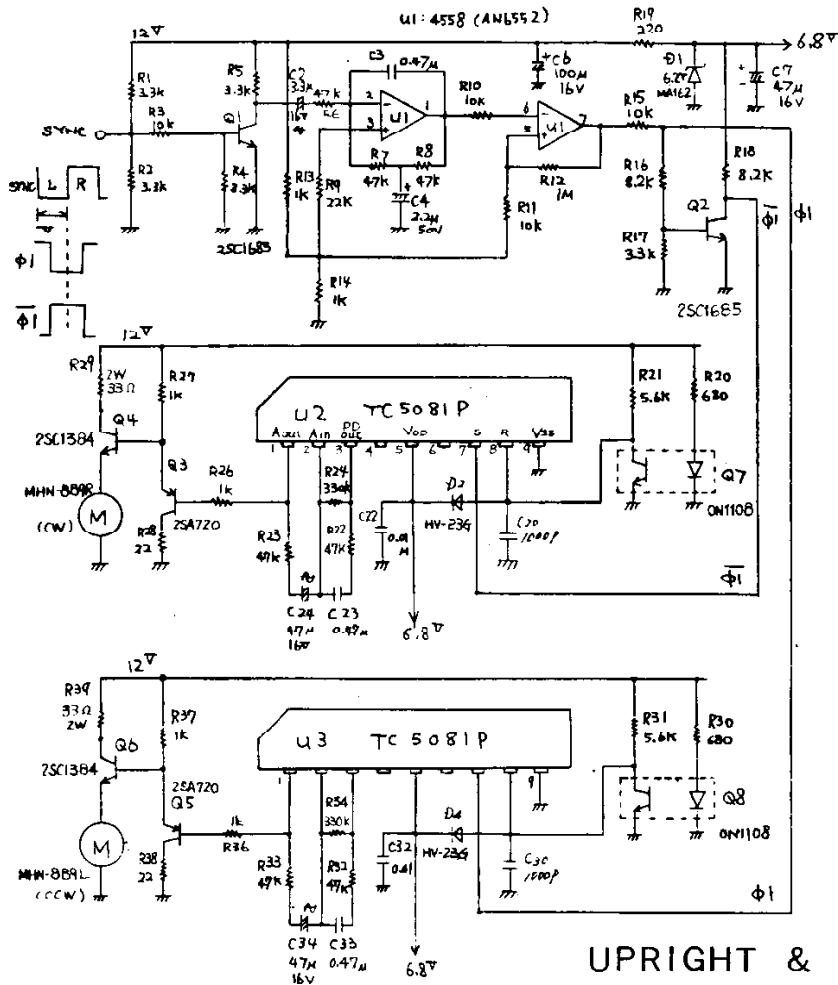
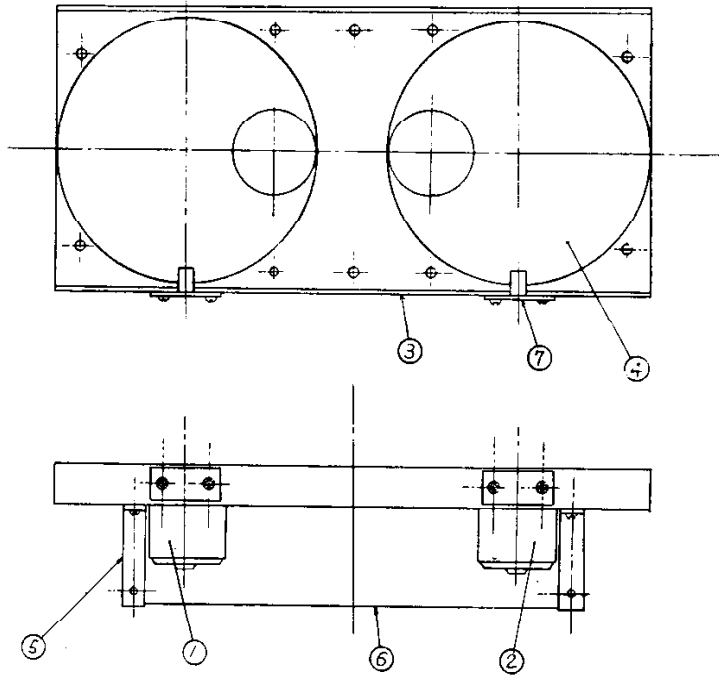

UPRIGHT &
COCKPIT TYPE

ASSY SHUTTER FOR 3D (834-0346)

ITEM NO.	PART NO.	DESCRIPTION
1	350-0183	Motor DC6V CW
2	350-0184	Motor DC6V CCW
3	FE-FFR421	Frame
4	FE-PRP002	Disc
5	FE-ZLT307	L bracket
7	FE-EPA433	Assy photo-interrupter

UPRIGHT & COCKPIT TYPE

ASSY HANDLE MECHANISM (TD-2056)

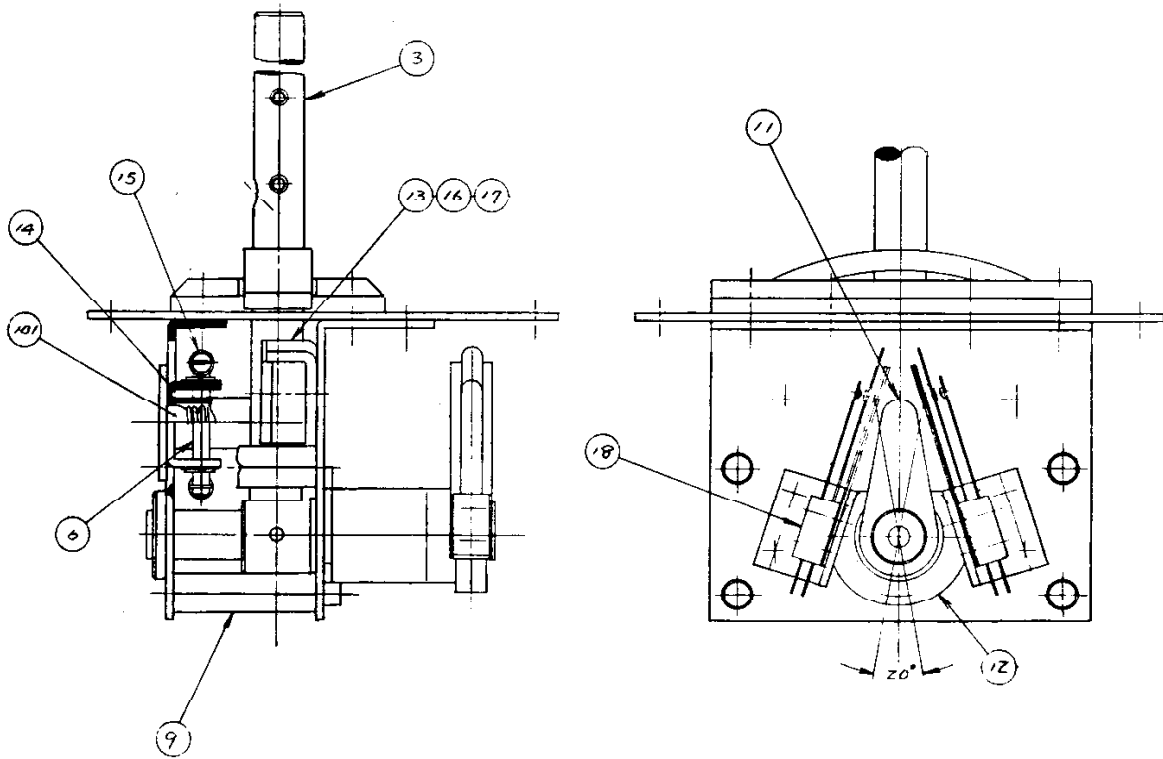

ITEM NO.	PART NO.	DESCRIPTION
3	TD-2044	Assy handle
6	TD-2010	Shaft
9	TD-2047	Spacer post 41.7
11	TD-2052	Assy cam
12	SH-3002	Handle retainer
13	SH-3003	Bumper bracket
14	FC-2541	Compression spring
15	MC-1043	Ext spring
16	2P-11600	Rubber bumper
17	2P-11601	Rubber retainer
18	509-0179	Molded switch for push button holder
101	101-0001	Steel ball 10.3188Ø

UPRIGHT & COCKPIT TYPE

ASSY POWER SUPPLY (TD-4000)

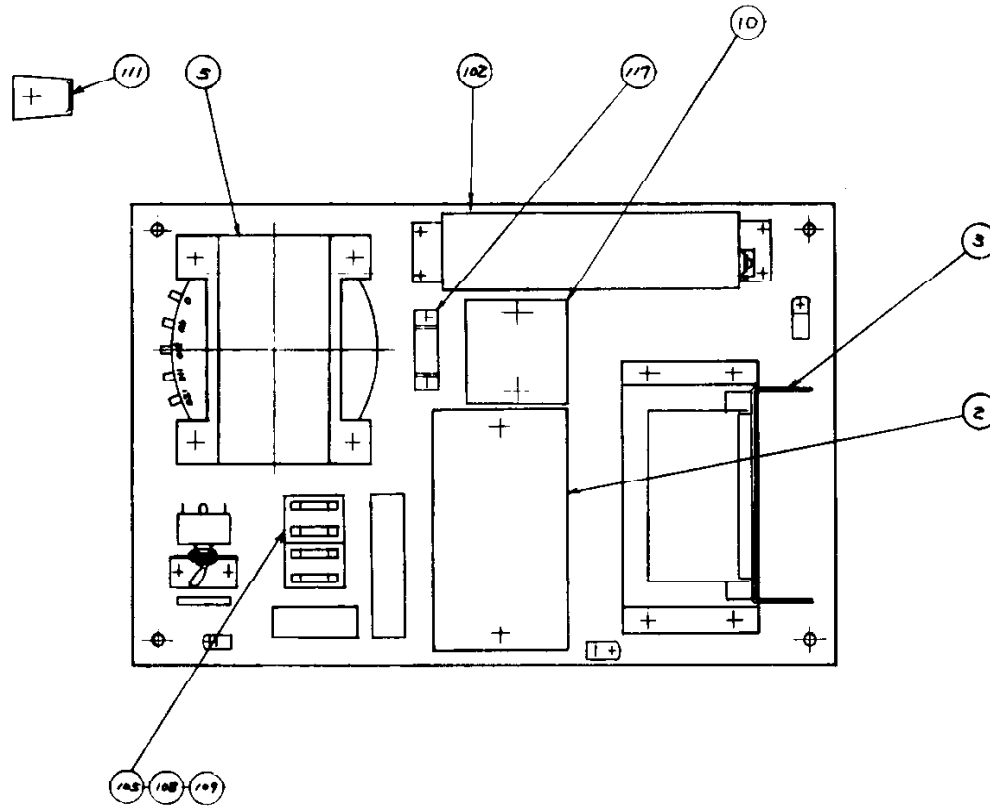

ITEM NO.	PART NO.	DESCRIPTION
2	834-0120	Assy regulator board (See page 42 for details)
3	TB-4600	Power amplifier DC 32V 16W (See page 36 for details)
5	560-0071	Power transformer 90-240V
10	M0-4002	Regulator unit DC 12V 20V (See page 38 for details)
102	601-0730	Switching regulator AC 100V 5V 10A (See page 39 for details)
107	514-0034	Fuse 5A
108	514-0040	Fuse 4A
109	514-0002	Fuse 3A
111	601-0552	AC cord connector body
117	481-0064	Diode bridge

UPRIGHT TYPE

POWER AMPLIFIER DC32V 16W (TB-4600)

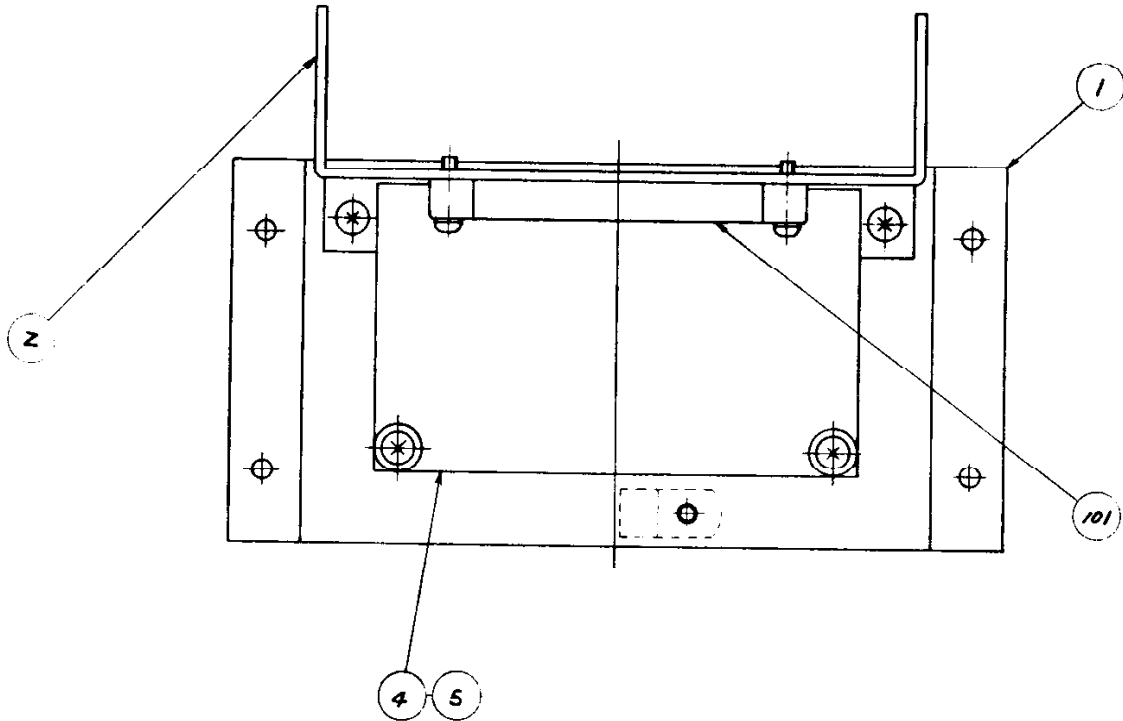

ITEM NO.	PART NO.	DESCRIPTION
1	TB-4601	Chassis
2	TB-4602	Heat sink
4	834-0121	ASSY POWER AMPLIFIER(See page 37 for details)
5	RM-3019	Spacer tube
101	315-0129	IC STK-439

UPRIGHT & COCKPIT TYPE

ASSY POWER AMPLIFIER (834-0121)

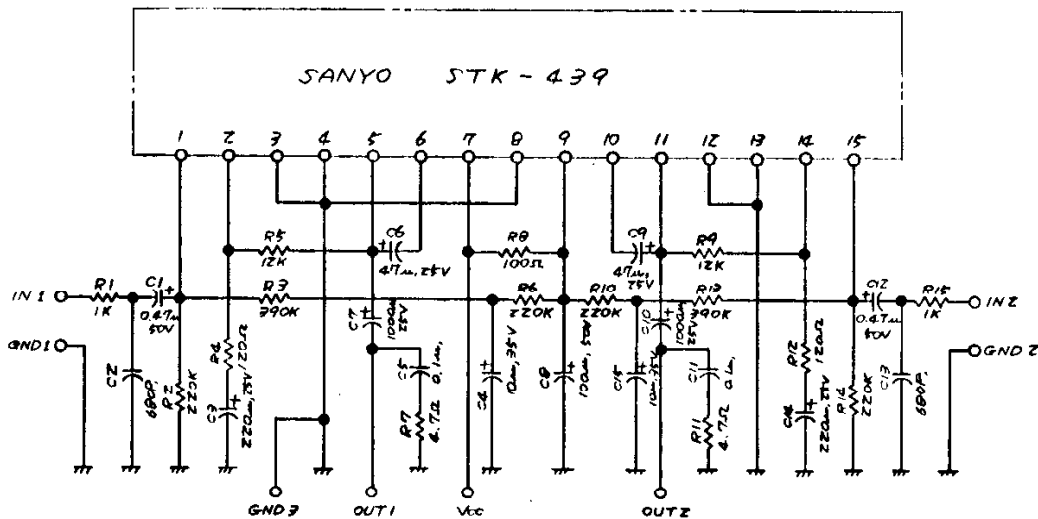
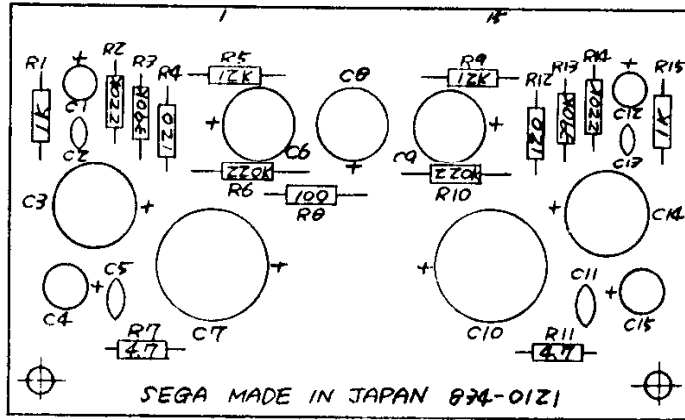

PART NO.	DESCRIPTION
171-0062	Printed board
470-04R7	Res 4.7 ohm 1/4W (R7, R11)
470-0101	Res 100 ohm 1/4W (R8)
470-0121	Res 120 ohm 1/4W (R4, R12)
470-0102	Res 1K ohm 1/4W (R1, R15)
470-0123	Res 12K ohm 1/4W (R5, R9)
470-0224	Res 220K ohm 1/4W (R2, R6, R10, R14)
470-0394	Res 390K ohm 1/4W (R3, R13)
152-0081	Cap film 680PF 50V (C2, C13)
152-0031	Cap film 0.1MF 50V (C5, C11)
150-0179	Cap E 0.47MF 50V U-Typ (C1, C12)
150-0165	Cap E 10MF 35V U-Typ (C4, C15)
150-0063	Cap E 47MF 25V U-Typ (C6, C9)
150-0215	Cap E 100MF 50V U-Typ (C8)
150-0093	Cap E 220MF U-Typ (C3, C14)
150-0174	Cap E 1000MF 25V U-Typ (C7, C10)

UPRIGHT & COCKPIT TYPE

REGULATOR UNIT DC12V 20V (MO-4002)

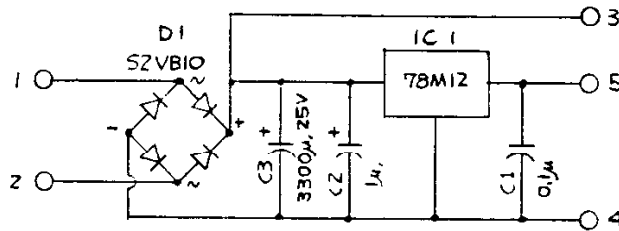
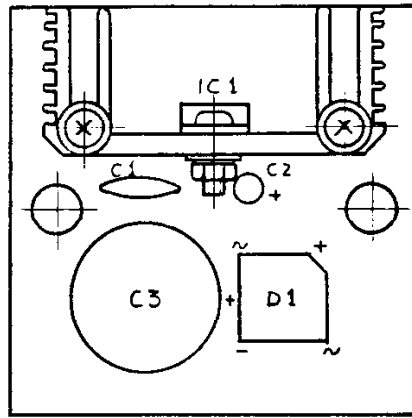

PART NO.	DESCRIPTION
MO-4002-A	Printed board
96447	Heat sink 6.2°C/W L=40
313-0117	IC μ A78M12UC (IC1)
481-0065	Rectifier silicon diode (D1)
151-0041	Condenser 0.1 μ F 25WV ceramic (C1)
153-0002	Condenser solid tantalum 1 μ F 25WV (C2)
150-0182	Condenser 3300 μ F 25WV CEO4 TYPE (C3)

UPRIGHT & COCKPIT TYPE

SWITCHING REGULATOR (601-0730)

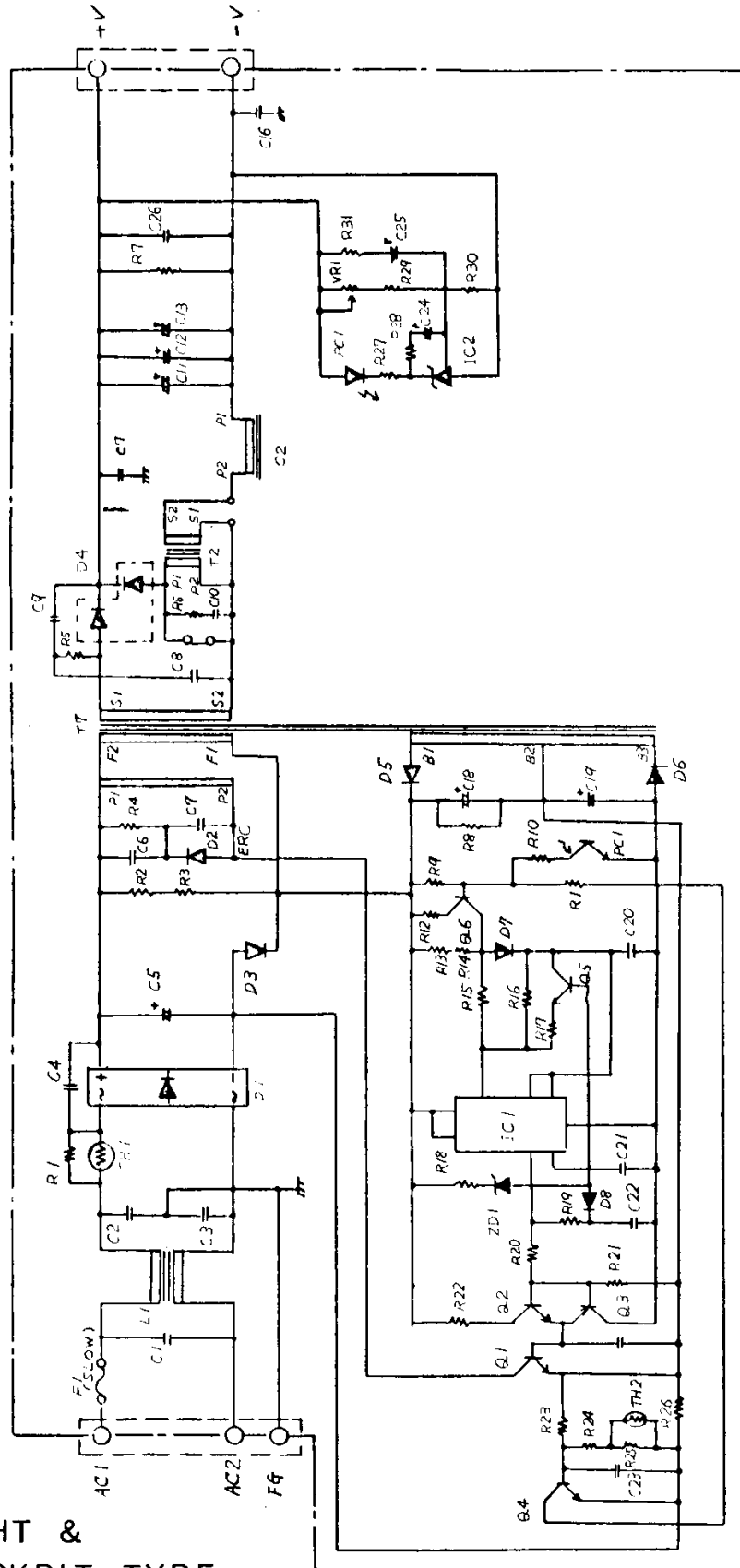

UPRIGHT &
COCKPIT TYPE

SWITCHING REGULATOR (601 - 0730)

Description		Symbol
Wirewound resistor 6.8 ohm 5W	ERF5SK6R8	R1
Metal oxide resistor 6.8 ohm 2W	ERG2ANJP682S	R2
Metal oxide resistor 6.8 ohm 2W	ERG2ANJP682S	R3
Metal oxide resistor 39K 1W	ERG1ANJP393S	R4
Metal oxide resistor 10 ohm 1W	ERG1ANJP100S	R5
Metal oxide resistor 33ohm 2W	ERG2ANJP330S	R7
Carbon film resistor 1K ohm 1/4W	ERD25TJ102X	R8
Carbon film resistor 560 ohm 1/4W	ERD25TJ561X	R9
Carbon film resistor 2.2K ohm 1/4W	ERD25TJ222X	R10
Carbon film resistor 1.8K ohm 1/4W	ERD25TJ182X	R11
Carbon film resistor 100 ohm 1/4W	ERD25TJ101X	R12
Carbon film resistor 8.2K ohm 1/4W	ERD25TJ822X	R13
Carbon film resistor 100 ohm 1/4W	ERD25TJ101X	R14
Carbon film resistor 820 ohm 1/4W	ERD25TJ821X	R15
Carbon film resistor 220K ohm 1/4W	ERD25TJ224X	R16
Carbon film resistor 12K ohm 1/4W	ERD25TJ123X	R17
Carbon film resistor 68K ohm 1/4W	ERD25TJ683X	R18
Carbon film resistor 1.5K ohm 1/4W	ERD25TJ152X	R19
Carbon film resistor 82 ohm 1/4W	ERD25TJ820X	R20
Carbon film resistor 470 ohm 1/4W	ERD25TJ471X	R21
Metal oxide resistor 15 ohm 2W	ERG2ANJP150S	R22
Metal oxide resistor 220 ohm 1/2W	ERG12ANJ221P	R23
Carbon film resistor 150 ohm 1/4W	ERD25TJ151X	R24
Carbon film resistor 180 ohm 1/4W	ERD25TJ181X	R25
Metal oxide resistor 0.47 ohm 2W	ERX2ANJPR47S	R26
Carbon film resistor 100 ohm 1/4W	ERD25TJ101X	R27
Carbon film resistor 100 ohm 1/4W	ERD25TJ101X	R28
Carbon film resistor 680 ohm 1/4W	ERD25TJ681X	R29
Carbon film resistor 1K ohm 1/4W	ERD25TJ102X	R30
Variable resistor 1K	EVMG1GA01B13	VR1
Transistor	2SC2739HD	Q1
Transistor	2SC1384	Q2
Transistor	2SA886	Q3
Transistor	2SC1685	Q4
Transistor	2SD889	Q5
Transistor	2SA564A	Q6
Diode	S4VB40	D1
Diode	ERC2506E	D2
Diode	ERB43 06K	D3
Diode	ESAC83-004	D4
Diode	ERC2506E	D5
Diode	ERB43-06K	D6
Diode	MA161LFS	D7
Diode	MA161LFS	D8
Zener diode	RD5.6E-B2	ZD1
	HA17555PS	IC1
	TL431CP	IC2
Opto isolator	ON3110	PC1
Thermistor	ERTD6FFK8ROX	TH1
Thermistor	ERTD2FGK750S	TH2

SWITCHING REGULATOR (601-0730)

Description		Symbol
Polyester capacitor 0.1MF 630V	ECQE6104MZB	C1
Ceramic capacitor 2200PF AC125V	ECKCDL222ZE3	C2
Ceramic capacitor 2200PF AC125V	ECKCDL222ZE3	C3
Ceramic capacitor 1000PF AC125V	ECKCDL102ZE3	C4
Electrolytic capacitor 330MF 200V	ECET2DR331SL	C5
Polyester capacitor 3300PF 630V	ECQF6332KZH	C6
Polyester capacitor 2200PF 630V	ECQF6222KZH	C7
Polyester capacitor 0.01MF 100V	ECQM1103KZB	C8
Electrolytic capacitor 1000 MF 10V	ECEA1AF102E	C11
Electrolytic capacitor 1000MF 10V	ECEA1AF102E	C12
Electrolytic capacitor 1000MF 10V	ECEA1AF102E	C13
Polyester capacitor 0.01MF 630V	ECQF6103KZH	C16
Polyester capacitor 0.01MF 630V	ECQF6103KZH	C17
Electrolytic capacitor 100MF 25V	ECEA1ES101E	C18
Electrolytic capacitor 33MF 16V	ECEA1CG330SE	C19
Polyester capacitor 1000PF 100V	AXS100K102	C20
Polyester capacitor 0.01MF100V	AXS100K103	C21
Polyester capacitor 0.1MF 100V	AXS100K104	C22
Polyester capacitor 1000PF 100V	AXS100K102	C23
Electrolytic capacitor 1MF 50V	ECEA1HSO10E	C24
Polyester capacitor 0.047MF 100V	AXS100K473	C26
Fuse 2A slow	HU-2CTZ	F1
Transformer	ETB-35KA38	T1
Filter choke	TLP6506P	L1
Smoothing choke	ETB-35KH27	L2

ASSY REGULATOR BOARD (834-0120)

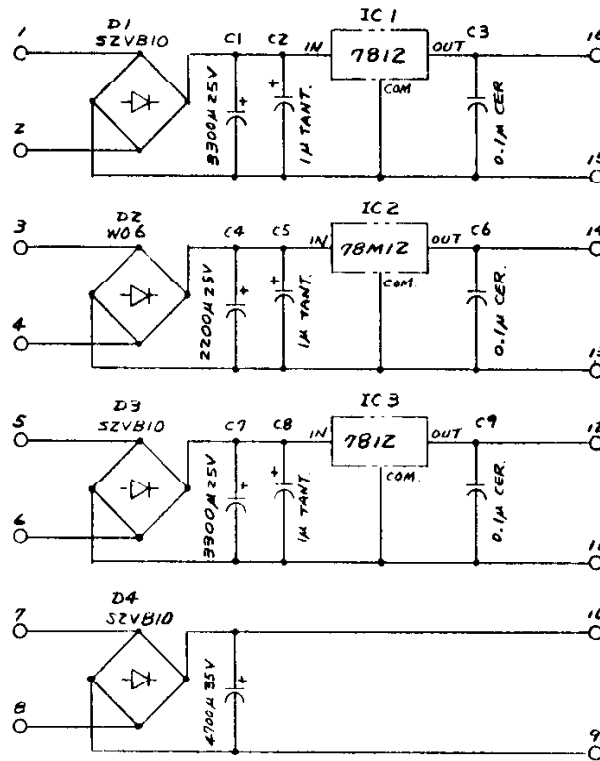
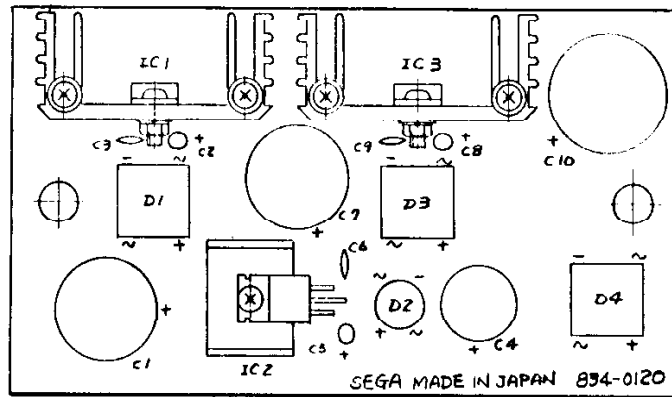

PART NO.	DESCRIPTION
313-0091	IC μ A78M12UC
313-0058	IC μ A7812UC
480-0042	Diode bridge W06
481-0065	Diode bridge S2VB10
150-0008	Cap E 2200 MF 25V U-Typ
150-0189	Cap E 3300 MF 25V U-Typ
150-0216	Cap E 4700 MF 35V U-Typ
153-0002	Cap tant 1 MF 25V
151-0041	Cap cer 0.1 MF 25V

UPRIGHT & COCKPIT TYPE

ASSY EMI FILTER BOARD (834-5060)

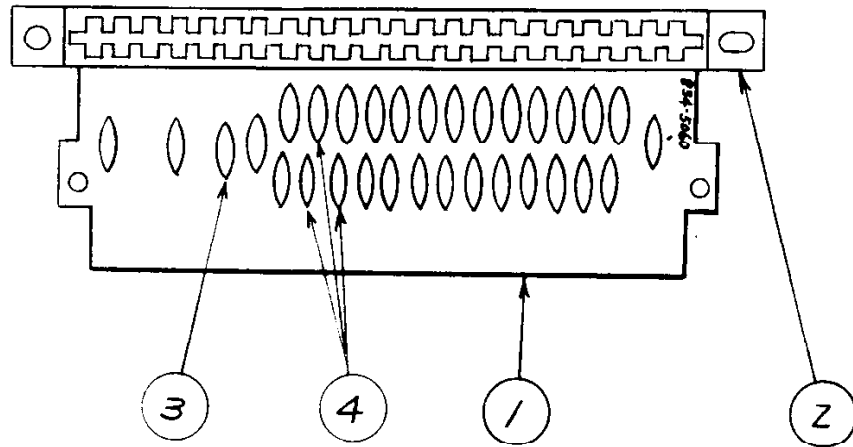

ITEM NO.	PART NO.	DESCRIPTION
1	171-5002	Printed board
2	209-5002	Conn 44P PGB DS
3	601-5001	EMI filter
4	601-5002	EMI filter

UPRIGHT & COCKPIT TYPE

TOP ASSY COCKPIT

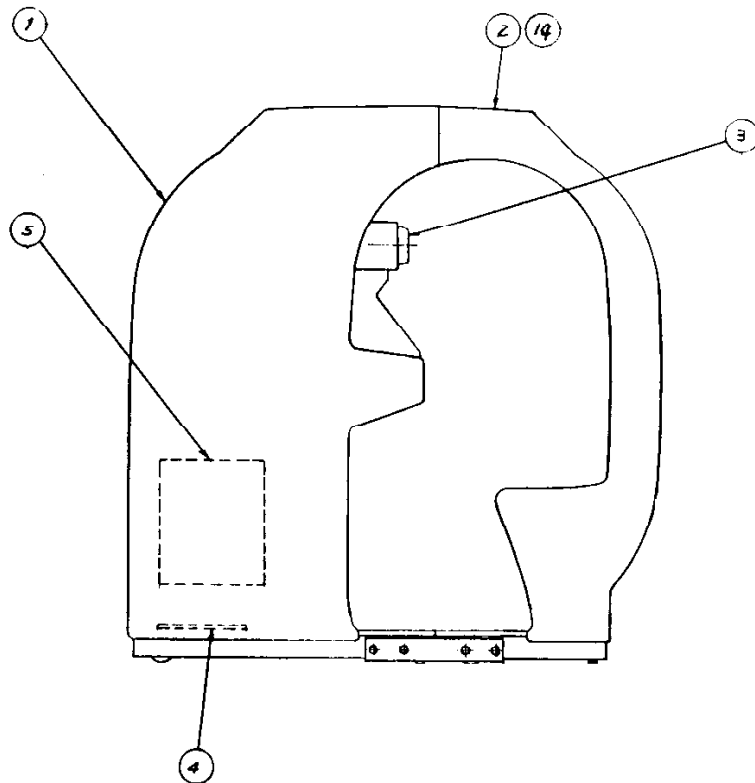

ITEM NO.	PART NO.	DESCRIPTION
1	TD-10001	ASSY CABINET FRONT HALF (See page 45 for details)
2	TD-12001	ASSY CABINET REAR HALF (See page 50 for details)
3	TD-20001	ASSY MECHANISM (See page 31 for details)
4	TD-40001	ASSY POWER SUPPLY (See page 53 for details)
5	834-0357	ASSY IC BOARD SUBROC-3D EXPORT
	834-0358	Assy IC board SUBROC-3D CPU USA
	834-5058	Assy IC board SUBROC-3D PROM USA
	834-0246	Assy sound board SUBROC-3D
6	834-5060	ASSY EMI FILTER BOARD (See page 43 for details)
14	TD-0005	Sticker SUBROC-3D

COCKPIT TYPE

ASSY CABINET FRONT HALF (TD-10001)

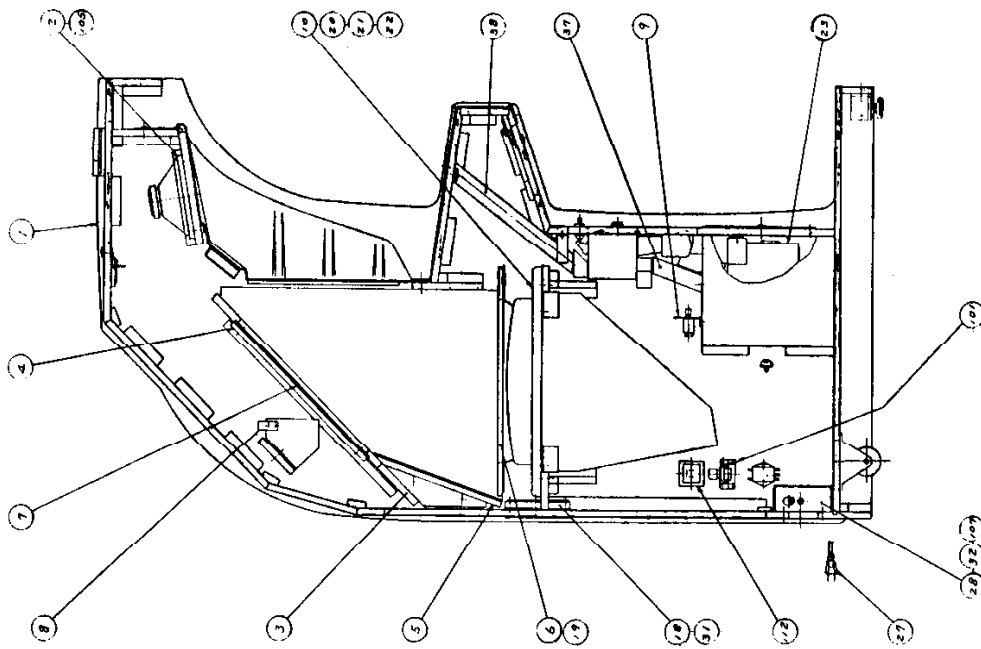
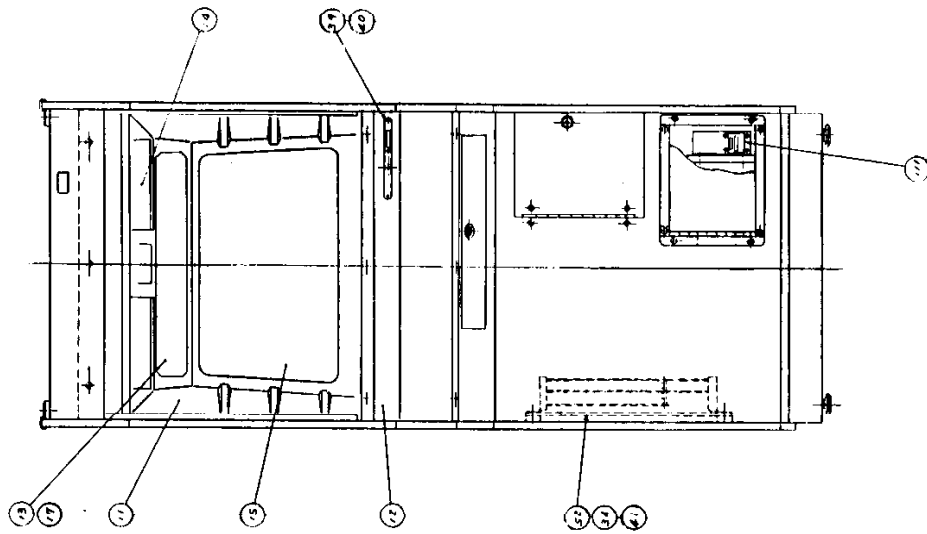

COCKPIT TYPE

ASSY CABINET FRONT HALF (TD-10001)

ITEM NO.	PART NO.	DESCRIPTION
1	TD-1064	ASSY SUB-CABINET FRONT HALF (HIGH CAB.) (See page 48 for details)
2	TD-1005	Speaker board
3	TD-1006	Mirror board
4	TD-1007	Holder
5	TD-1008	Partition board
6	TD-1009	Mask board
7	TD-1016	Half mirror
8	TD-1058	SIGHT UNIT (See page 47 for details)
9	TD-1028	CONTROL UNIT (See page 30 for details)
11	TD-1048	Front mask
12	TD-1049	Front panel
13	TD-1032	Score panel
14	TD-1033	Speaker guard plate
15	TD-1034	Front window
17	TD-1100	ASSY SCORE BOARD (See page 28 for details)
19	AB-1166Z	TV mask T8 20
20	200-0039	Assy color display 20 type 100V
27	600-0110	Assy cable & plug w/Earth
39	AB-1038X	Coin entry plate USA 25¢ twin
40	83617	Denomination plate 20¢X2
41	600-0117	Assy fem & flat cable 50P
101	509-0039	Switch push button type
103	481-0027	Rectifier silicon diode
105	130-0018	Speaker 16cm 8Ω
107	280-0418	Bushing strain relief 83
110	601-0429	Noise filter AC 250V 4A
111	220-0213	Coin counter 6 digits DC 5V
114	260-0011	Axial flow fan AC 100V

Please refer to the separate book called the
"DISPLAY MANUAL" concerning the color monitor.

COCKPIT TYPE

SIGHT UNIT (TD-1058)

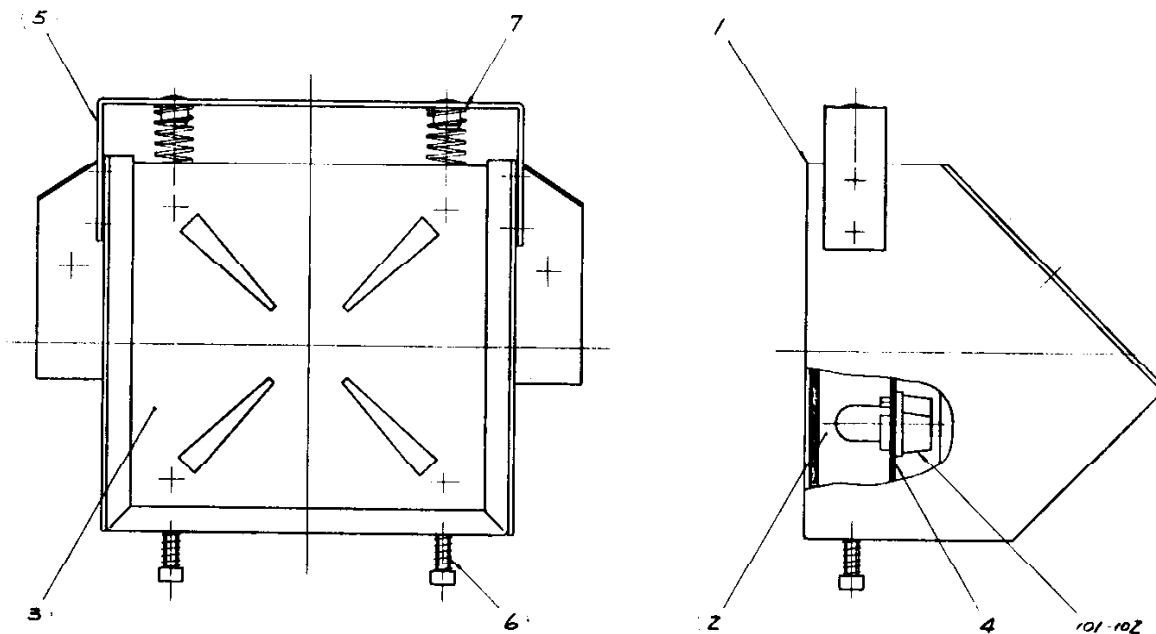

ITEM NO.	PART NO.	DESCRIPTION
1	TD-1021	Frame
2	TD-1022	Lamp board
3	TD-1023	Sight plate
4	TD-1024	Lamp holder board
5	TD-1025	Bracket
6	TD-1026	Compression spring
7	TD-1027	Compression spring
101	214-0081	Assy wedge base socket
102	390-0116	Lamp wedge base type 14V 0.24A
	SGB-3158-16	Wire harness LP

COCKPIT TYPE

ASSY SUB-CABINET FRONT HALF (TD-1064)

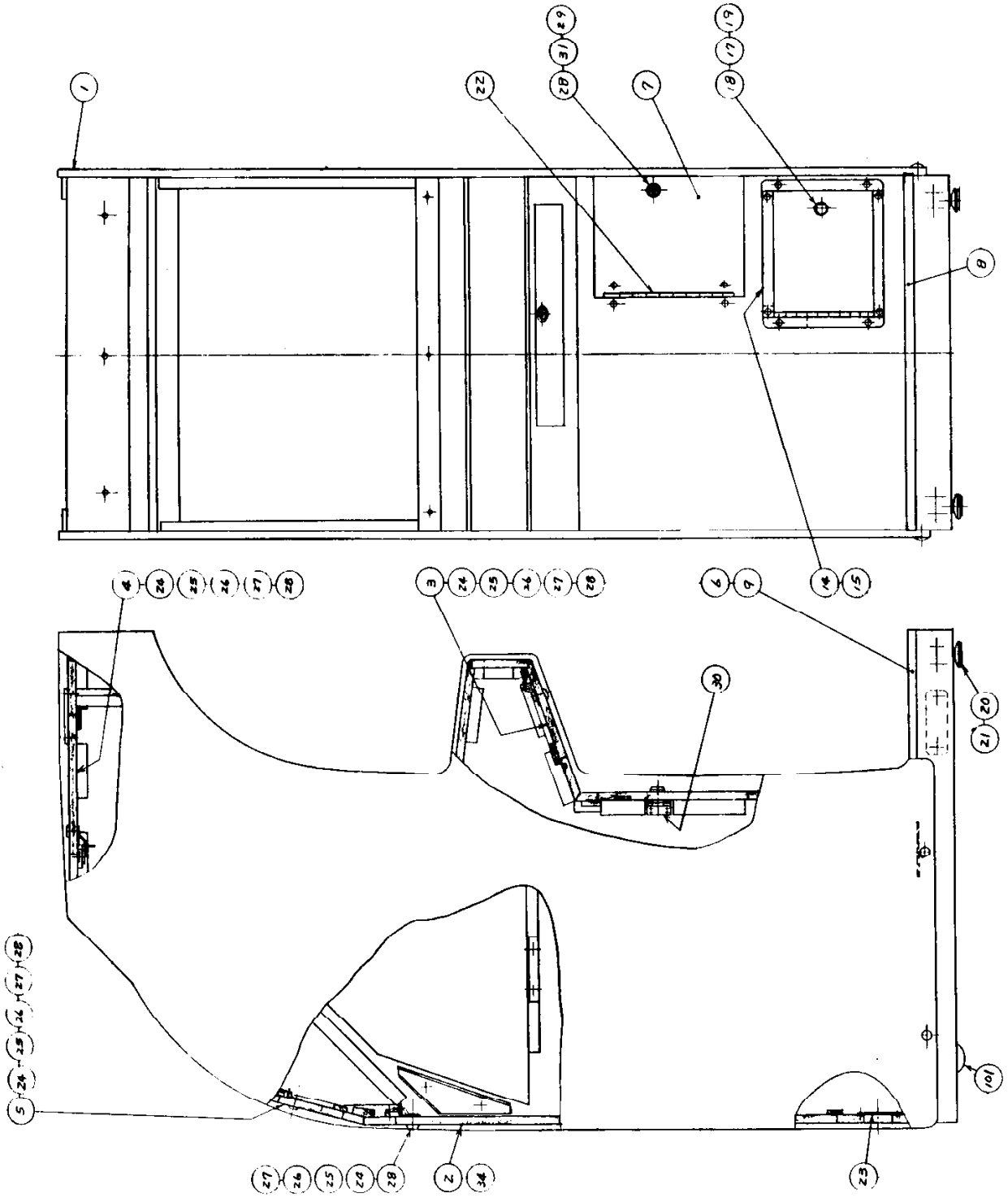

COCKPIT TYPE

ASSY SUB-CABINET FRONT HALF (TD-1064)

ITEM NO	PART NO.	DESCRIPTION
1	TD-1039	Wooden cabinet front half
	TD-1065	Wooden cabinet front half Export (High cabinet)
2	TD-1040	Back door
3	TD-1041	Service door, roof
4	TD-1042	Service door
5	TD-1043	Service door
6	TD-1044	Floor mat
7	TD-1045	Coin chute door
18	220-0097	Ace cylinder lock w/keys
19	280-0406	Spacer ring Turbo
21	601-0753	Leg adjuster
23	MO-1044	Net plate
24	280-0401	Tongue locking
25	117-0063	Plate tongue retainer
27	117-0062	Lock retainer plate
28	220-0224	Ace cylinder lock, L.S. Type Master w/o key
29	220-0225	Key Master "XA-1040"
34	PT-0342	Air vent
35	PT-0015	Net
101	601-0391	Caster

COCKPIT TYPE

ASSY CABINET REAR HALF (TD-12001)

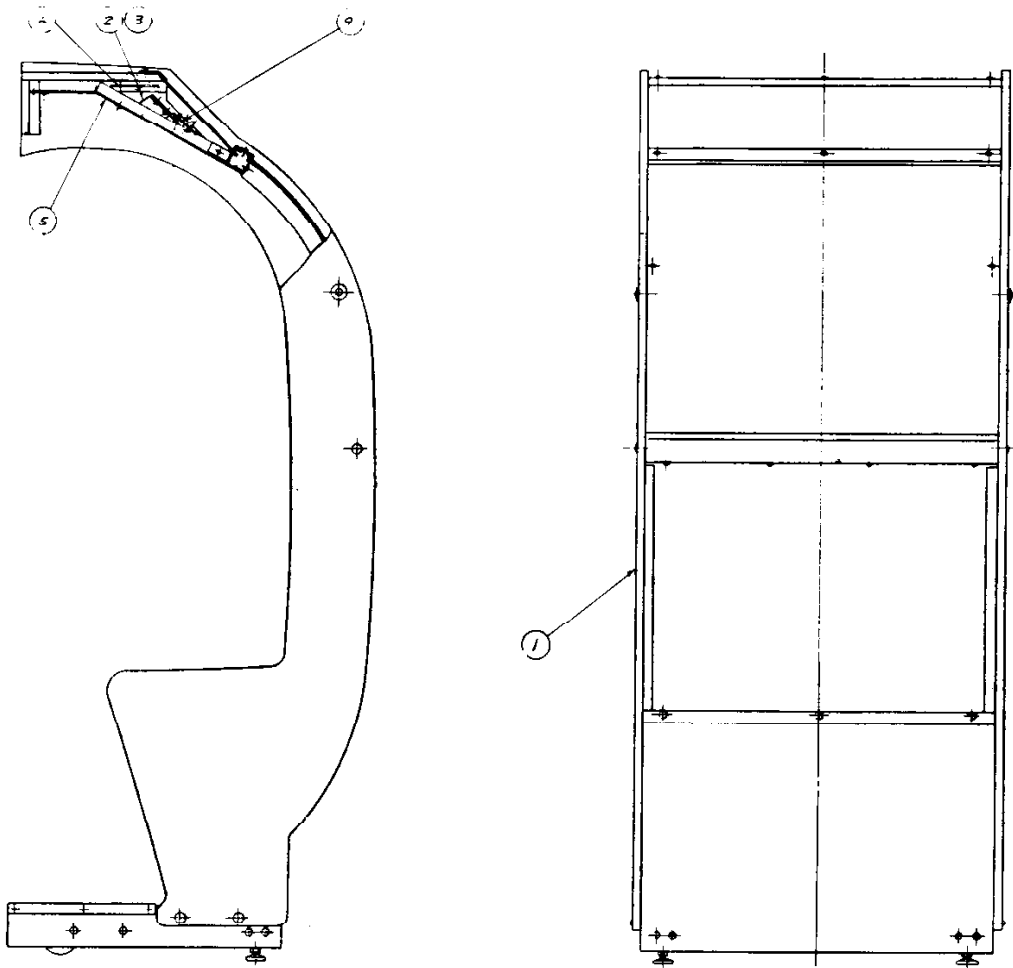

ITEM NO.	PART NO.	DESCRIPTION
1	TD-1220	ASSY SUB-CABINET REAR HALF (High cabinet) (See pages 52 for details)
2	TD-1214	Bracket left
3	TD-1215	Bracket right
5	TD-1217	Cover
6	834-0341	Assy lamp control board (See page 51 for details)
9	TD-1219	Lamp holder board
103	390-0116	Lamp wedge base type 14V 0.24A
104	214-0081	Assy wedge base socket

COCKPIT TYPE

ASSY LAMP CONTROL BOARD (834-O341)

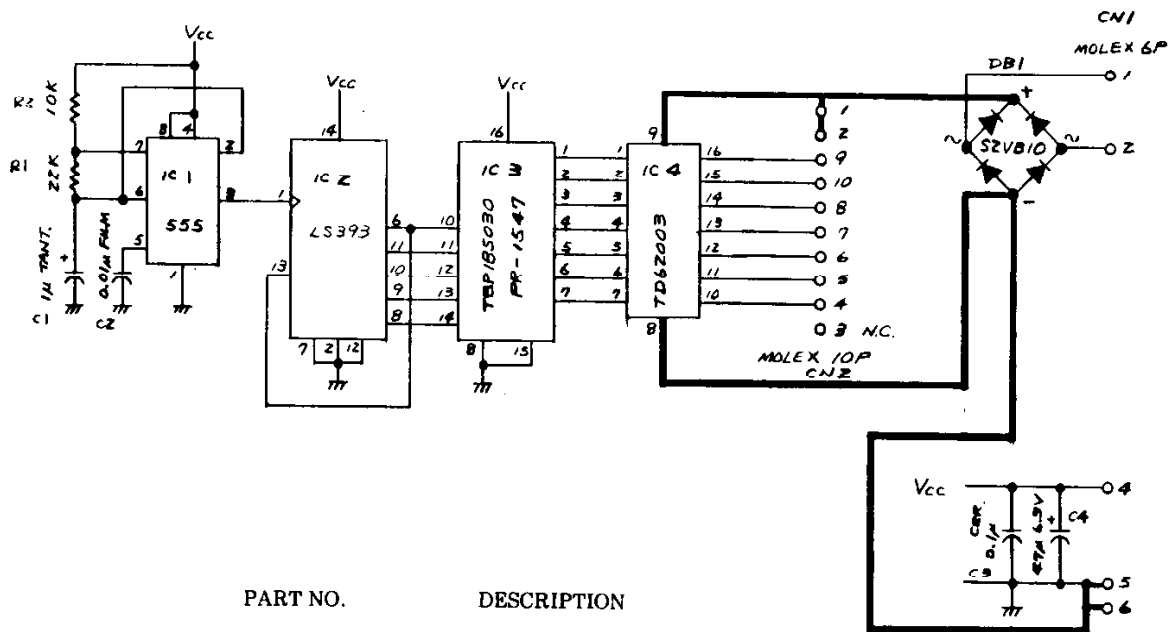
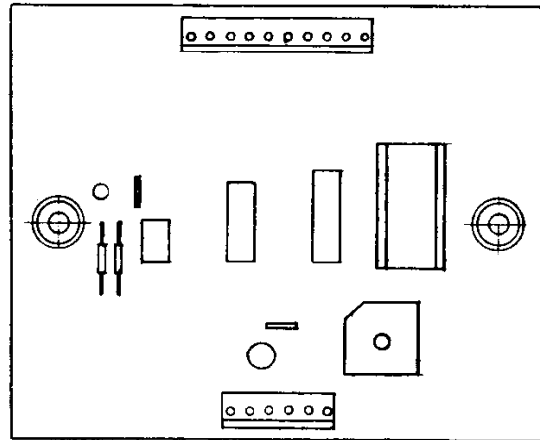

PART NO.	DESCRIPTION
171-0094	Printed board
530-0019	Heat sink
314-0075	IC 74LS393(IC2)
314-0001	IC NE555 DIP (IC1)
313-0086	IC TD62003 (IC4)
316-1547	IC TBP18S030PR-1547 (IC3)
152-0033	Cap film 0.01MF 50V (C2)
151-0041	Cap cer 0.1MF 25V (C3)
153-0002	Cap tant 1MF 25V (C1)
150-0156	Cap E 47MF 6.3V (C4)
470-0103	Res 10K ohm 1/4W (R2)
470-0223	Res 22K ohm 1/4W (R1)
481-0065	Diode bridge S2VBIO (DB1)
212-0157	Conn M6 pin
212-0021	Conn M10 pin

COCKPIT TYPE

ASSY SUB-CABINET REAR HALF (TD-1220)

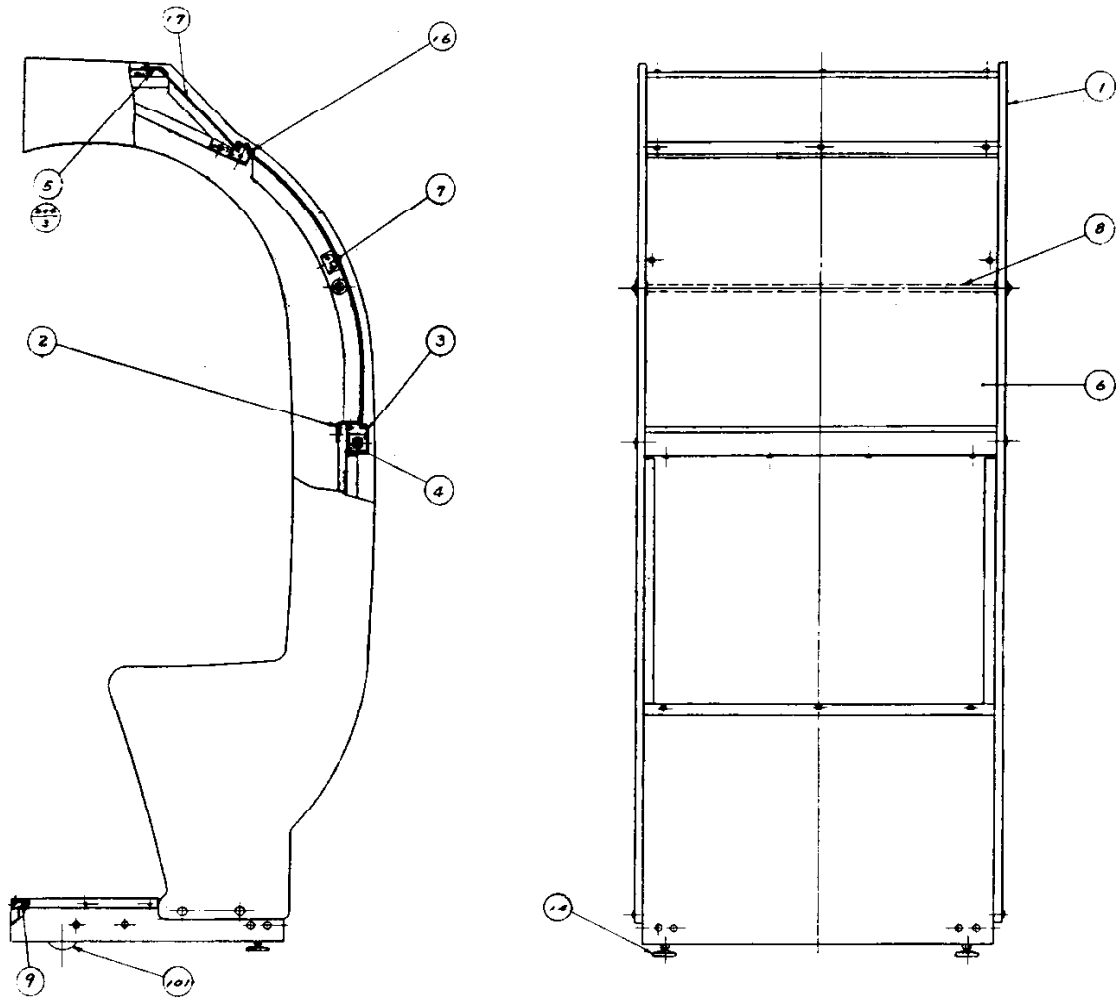

ITEM NO.	PART NO.	DESCRIPTION
1	TD-1221	Wooden cabinet rear half Export (high cabinet)
2	TD-1202	Supporter
3	TD-1203	Ornament
4	TD-1204	Bracket A
5	TD-1205	Top frame
6	TD-1206	Hood
7	TD-1207	Bracket B
8	TD-1208	Rod
9	TD-1209	Floor mat
14	601-0753	Leg adjuster
16	TD-1212	Upper ornament
17	TD-1213	Top panel SUBROC-3D
101	601-0391	Caster

COCKPIT TYPE

ASSY POWER SUPPLY (TD-40001)

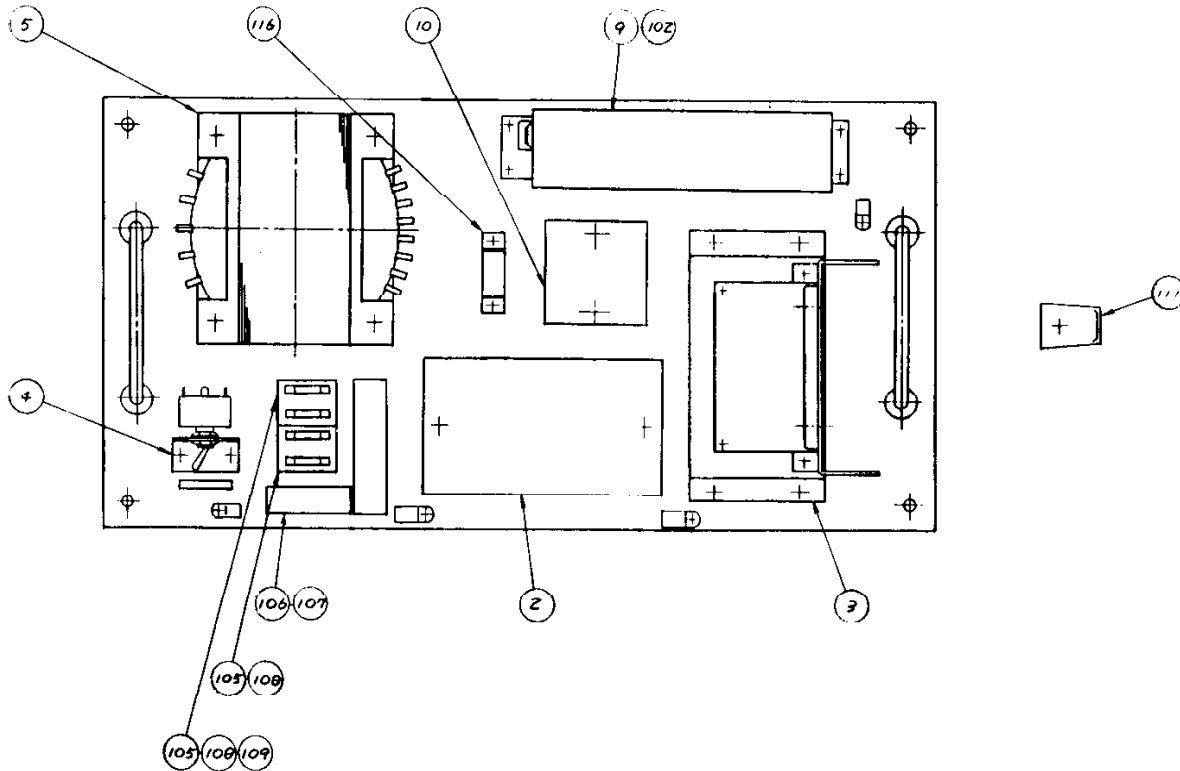

ITEM NO.	PART NO.	DESCRIPTION
2	834-0120	Assy regulator board (See page 42 for details)
3	TB-4600	Power amplifier DC 32V 16W (See page 36 for details)
4	BS-3004	Bracket
5	560-0090	Power transformer 90-240V
10	MO-4002	Regulator unit DC 12V 20V (See page 38 for details)
102	601-0730	Switching regulator AC 100V 5V 10A
107	514-0034	Fuse 5A
108	514-0040	Fuse 4A
109	514-0002	Fuse 3A
111	601-0552	AC cord connector body flat type
116	481-0064	Diode bridge

COCKPIT TYPE

ASSY IC BOARD SUBROC-3D

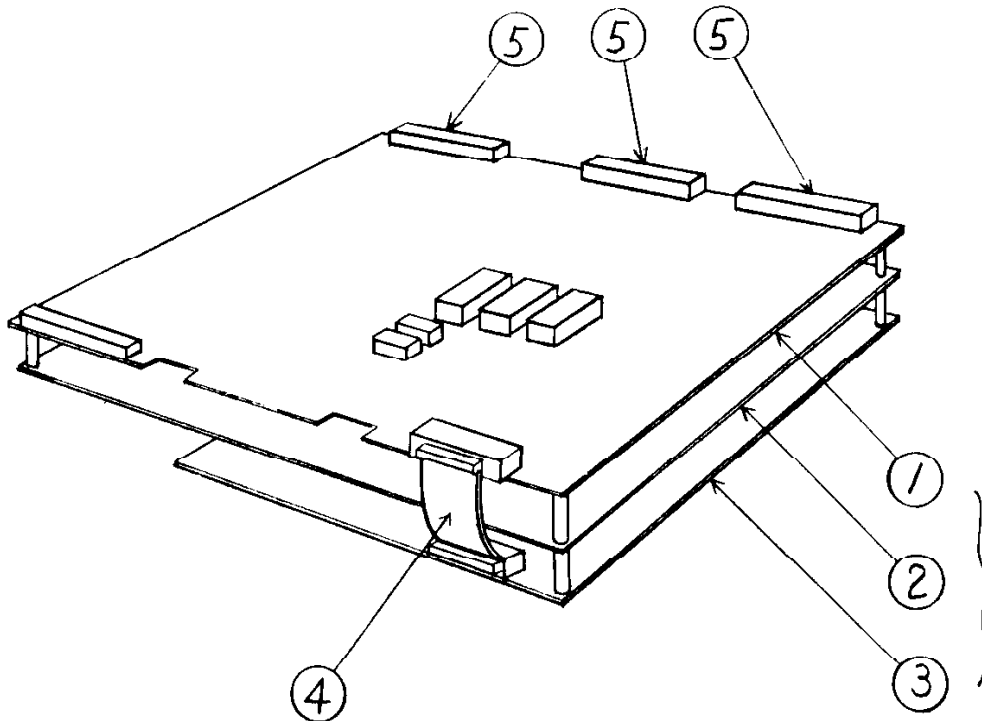

ITEM NO.	PART NO.	DESCRIPTION
1	834-0358	Assy IC board SUBROC-3D CPU
2	834-5058	Assy IC board SUBROC-3D PROM
3	834-0246	Assy sound board SUBROC-3D
4	600-0116	Assy FEM & FLAT cable 26P
5	600-0095	Assy FEM & FLAT cable 50P

ASSY IC BOARD CPU (834-0358)

ITEM NO.	PART NO.	DESCRIPTION
1	171-0081	PRINTED BOARD
101	315-0041	IC 280A
102	315-0152	IC 8255A-5
103	316-1614	IC 2763 EPR-1614
104	316-1615	IC 2763 EPR-1615
105	316-1616	IC 2763 EPR-1616
107	316-1617	IC 2716 EPR-1617
108	316-1618	IC 2716 EPR-1618
109	316-1449	IC μ PB425D PR-1449
110	316-1450	IC μ PB425D PR-1450
111	316-1451	IC μ PB425D PR-1451
112	316-1619	IC μ PB425D PR-1619
113	316-1453	IC TBP18S030 PR-1453
114	316-1454	IC TBP18S030 PR-1454
115	316-1620	IC TBP24SION PR-1620
116	315-0125	IC MB8128-15
117	315-0126	IC MB8148-55
118	313-0086	IC TD62003P
119	314-0018	IC 74LS00
120	314-0078	IC 74LS02
121	314-0019	IC 74LS04

ITEM NO.	PART NO.	DESCRIPTION
123	314-0046	IC 74S04
124	314-0060	IC 74LS20
125	314-0068	IC 74LS32
126	314-0106	IC 74LS51
127	314-0062	IC 74LS74
128	314-0070	IC 74LS86
129	314-0237	IC 74LS109
130	314-0080	IC 74LS123
131	314-0104	IC 74LS138
132	314-0071	IC 74LS151
133	314-0252	IC 74LS155
134	314-0076	IC 74LS157
135	314-0233	IC 74161
136	314-0097	IC 74LS161
137	314-0127	IC 74LS164
138	314-0077	IC 74LS166
139	314-0072	IC 74LS174
140	314-0073	IC 74LS175
142	314-0099	IC 74LS245
143	314-0105	IC 74LS253
144	314-0100	IC 74LS273
145	314-0101	IC 74LS283
146	314-0102	IC 74LS367
147	314-0093	IC 74LS374
148	212-0119	CONN M26PIN
149	212-0115	CONN M50PIN
150	213-0005	SKT 40PIN DUAL INLN
151	213-0012	SKT 28PIN DUAL INLN
152	213-0001	SKT 24PIN DUAL INLN
153	213-0002	SKT 18PIN DUAL INLN
154	213-0004	SKT 16PIN DUAL INLN
155	230-0041	CRYSTAL 19.968MHZ
156	390-0100	LED TIL220 RED
157	510-0049	SWITCH 8POS DIP SPST
158	482-0240	TRANSISTOR 2SC1684
159	211-0008	CONN PIN TEST PT
160	477-0005	RES PACK 8x4.7K OHM 1/8W
162	477-0008	RES PACK 8x560 OHM 1/8W
163	477-0009	RES PACK 8x100 OHM 1/4W
164	470-0221	RES 220 OHM 1/4W 5%
165	470-0331	RES 330 OHM 1/4W 5%
166	470-0471	RES 470 OHM 1/4W 5%
167	470-0102	RES 1K OHM 1/4W 5%
168	470-0222	RES 2.2K OHM 1/4W 5%
169	470-0472	RES 4.7K OHM 1/4W 5%
170	470-0103	RES 10K OHM 1/4W 5%
171	470-0473	RES 4.7K OHM 1/4W 5%
172	150-0042	CAP E 470MF 6.3V U-TYP
173	150-0065	CAP E 47MF 16V U-TYP
174	150-0023	CAP E 10MF 16V U-TYP
175	153-0025	CAP TANT 10MF 6.3V
176	151-0042	CAP CER 470pF 50V
177	151-0040	CAP CER 001MF 25V
178	151-0041	CAP CER 01MF 25V
179	315-0101	IC 8279C-5
180	314-0173	IC 74LS48N
181	314-0144	IC 74LS145
182	482-0292	TRANSISTOR 2SB761
183	477-0042	RES PACK 8x560 OHM 1/4W
184	462-0091	RES 33 OHM 2W METAL OXIDE FILM
185	314-0234	IC 7425

ASSY IC BOARD PROM (834-5058)

ITEM NO.	PART NO.	DESCRIPTION
1	171-0082	PRINTED BOARD
101	314-0070	IC 74LS86
102	314-0237	IC 74LS109
103	314-0277	IC 74LS137
104	314-0104	IC 74LS138
105	314-0087	IC 74LS139
106	314-0076	IC 74LS157
107	314-0074	IC 74LS191
108	314-0100	IC 74LS273
109	314-0257	IC 74LS626
110	314-0132	IC 75365
111	313-0090	IC μ PC159A
112	313-0092	IC μ A7805UC
113	313-0039	IC T1084UN
114	315-0124	IC μ PC624D
115	315-0045	IC CD4066
116	316-1417	IC 2763 EPR-1417
117	316-1418	IC 2763 EPR-1418
118	316-1419	IC 2763 EPR-1419
119	316-1420	IC 2763 EPR-1420
120	316-1421	IC 2763 EPR-1421
121	316-1422	IC 2763 EPR-1422
122	316-1423	IC 2763 EPR-1423
123	316-1424	IC 2763 EPR-1424
124	316-1425	IC 2763 EPR-1425
125	316-1426	IC 2763 EPR-1426
126	316-1427	IC 2763 EPR-1427
127	316-1664	IC 2763 EPR-1664
128	316-1429	IC 2763 EPR-1429
129	316-1430	IC 2763 EPR-1430
130	316-1665	IC 2763 EPR-1665
131	316-1432	IC 2763 EPR-1432
132	316-1433	IC 2763 EPR-1433
133	316-1666	IC 2763 EPR-1666
134	316-1435	IC 2763 EPR-1435
135	316-1436	IC 2763 EPR-1436
136	316-1437	IC 2763 EPR-1437
137	316-1438	IC 2763 EPR-1438
138	316-1439	IC 2763 EPR-1439
139	316-1440	IC 2763 EPR-1440
142	212-0115	CONN M 50PIN
143	213-0012	SKT 28PIN DUAL INLN
144	213-0004	SKT 16PIN DUAL INLN
145	390-0100	LED TIL220 RED
146	481-0031	DIODE MA150
147	477-0042	RES PACK 8x560 OHM 1/4W
148	470-0221	RES 220 OHM 1/4W 5%
149	470-0331	RES 330 OHM 1/4W 5%
150	470-0102	RES 1K OHM 1/4W 5%
151	470-0152	RES 15K OHM 1/4W 5%
152	470-0222	RES 22K OHM 1/4W 5%
153	470-0392	RES 39K OHM 1/4W 5%
	470-0122	RES 12K OHM 1/4W 5%
154	150-0042	CAP E 470MF 6.3V U-TYP
	150-0160	CAP E 470MF 16V U-TYP
155	150-0059	CAP E 100MF 16V U-TYP
156	153-0025	CAP TANT 10MF 6.3V
157	153-0002	CAP TANT 1MF 25V

ITEM NO.	PART NO.	DESCRIPTION
158	151-0002	CAP CER 100pF 50V
159	151-0005	CAP CER 680pF 50V
160	151-0008	CAP CER 0001MF 50V
161	151-0041	CAP CER 01MF 25V
162	155-0011	CAP SILVERD MICA 100pF 500V 5%
163	155-0012	CAP SILVERD MICA 220pF 500V 5%
164	211-0008	CONN PIN TEST PT
201	530-0024	HEAT SINK

ASSY SOUND BOARD (834-0246)

ITEM NO.	PART NO.	DESCRIPTION
1	171-0083	PRINTED BOARD
101	314-0146	IC 7416
102	314-0051	IC 7417
103	314-0016	IC 74123
104	315-0033	IC CD4016B
105	315-0078	IC CD4051B
106	315-0079	IC CD4053B
107	315-0161	IC MC14175D
108	313-0084	IC MB4391M
109	314-0001	IC NE555 DIP
110	315-0035	IC MM5837
111	313-0034	IC LM324
112	313-0109	IC MN3009
113	313-0040	IC MN3101
114	313-0042	IC AN6551
115	470-0681	RES 680 OHM 1/4W 5%
116	470-0821	RES 820 OHM 1/4W 5%
117	470-0101	RES 100 OHM 1/4W 5%
118	470-0331	RES 330 OHM 1/4W 5%
119	470-0471	RES 470 OHM 1/4W 5%
120	470-0102	RES 1K OHM 1/4W 5%
121	470-0122	RES 12K OHM 1/4W 5%
122	470-0152	RES 15K OHM 1/4W 5%
123	470-0222	RES 22K OHM 1/4W 5%
124	470-0272	RES 27K OHM 1/4W 5%
125	470-0332	RES 33K OHM 1/4W 5%
126	470-0392	RES 39K OHM 1/4W 5%
127	470-0472	RES 47K OHM 1/4W 5%
128	470-0512	RES 51K OHM 1/4W 5%
129	470-0562	RES 56K OHM 1/4W 5%
130	470-0682	RES 68K OHM 1/4W 5%
131	470-0103	RES 10K OHM 1/4W 5%
132	470-0123	RES 12K OHM 1/4W 5%
133	470-0153	RES 15K OHM 1/4W 5%
134	470-0223	RES 22K OHM 1/4W 5%
135	470-0273	RES 27K OHM 1/4W 5%
136	470-0303	RES 30K OHM 1/4W 5%
137	470-0333	RES 33K OHM 1/4W 5%
138	470-0393	RES 39K OHM 1/4W 5%
139	470-0473	RES 47K OHM 1/4W 5%
140	470-0513	RES 51K OHM 1/4W 5%
141	470-0563	RES 56K OHM 1/4W 5%
142	470-0683	RES 68K OHM 1/4W 5%
143	470-0104	RES 100K OHM 1/4W 5%
144	470-0124	RES 120K OHM 1/4W 5%
145	470-0154	RES 150K OHM 1/4W 5%
146	470-0204	RES 200K OHM 1/4W 5%
147	470-0224	RES 220K OHM 1/4W 5%

ITEM NO.	PART NO.	DESCRIPTION
148	470-0274	RES 270K OHM 1/4W 5%
149	470-0334	RES 330K OHM 1/4W 5%
150	470-0474	RES 470K OHM 1/4W 5%
151	470-0105	RES 1M OHM 1/4W 5%
152	477-0005	RES PACK 8x4.7K OHM 1/8W
153	477-0037	RES PACK 8x10K OHM 1/8W
	470-0125	RES 12M OHM 1/4W 5%
157	481-0031	DIODE MA150
158	482-0043	TRANSISTOR 2SC458,C
	470-0823	RES 82K OHM 1/4W 5%
159	150-0016	CAP E 1MF 16V U-TYP
160	150-0014	CAP E 22MF 25V U-TYP
161	150-0166	CAP E 33MF 25V U-TYP
162	150-0007	CAP E 47MF 16V U-TYP
163	150-0023	CAP E 10MF 16V U-TYP
164	150-0065	CAP E 47MF 16V U-TYP
165	150-0160	CAP E 470MF 16V U-TYP
167	151-0018	CAP CER 150PF 50V
168	151-0005	CAP CER 680PF 50V
169	151-0041	CAP CER 0.1MF 25V
170	152-0067	CAP FILM 220PF 50V
171	152-0054	CAP FILM 0001MF 50V
172	152-0078	CAP FILM 00068MF 50V 5%
173	152-0033	CAP FILM 001MF 50V
174	152-0079	CAP FILM 0022MF 50V 5%
175	152-0035	CAP FILM 0033MF 50V
176	152-0072	CAP FILM 0039MF 50V
177	152-0038	CAP FILM 0047MF 50V
178	152-0066	CAP FILM 0068MF 25V
179	153-0038	CAP TANT 0.68MF 16V
180	153-0002	CAP TANT 1MF 25V
181	153-0003	CAP TANT 22MF 25V
182	153-0065	CAP TANT 33MF 16V
183	153-0045	CAP TANT 47MF 16V
184	153-0030	CAP TANT 68MF 16V
185	153-0066	CAP TANT 10MF 16V
187	153-0026	CAP TANT 22MF 16V
188	212-0119	CONN M 26PIN
189	212-0081	CONN M 4PIN RTA
190	212-0122	CONN M 6PIN RTA

CONTENTS OF DIAGRAMS

14	SCHEMATIC DIAGRAM UPRIGHT TYPE	59
	SCHEMATIC DIAGRAM COCKPIT TYPE	60
15	LOGIC DIAGRAM CPU (D-1/14 TO D-5/14)	61 ~ 65
	LOGIC DIAGRAM ROM (D-6/14 TO D-14/14)	66 ~ 74
	LOGIC DIAGRAM SOUND BOARD (D-1/5 TO D-5/5)	75 ~ 79

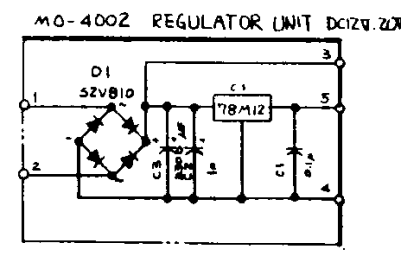
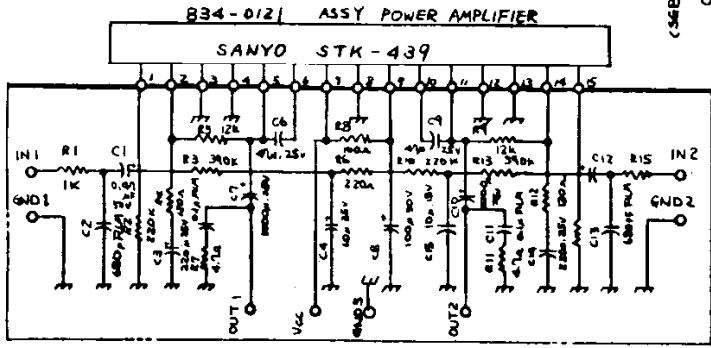
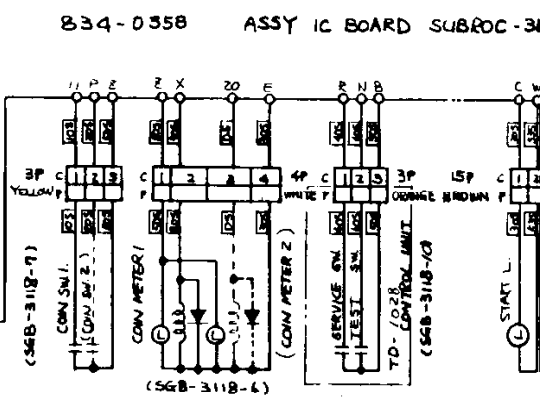
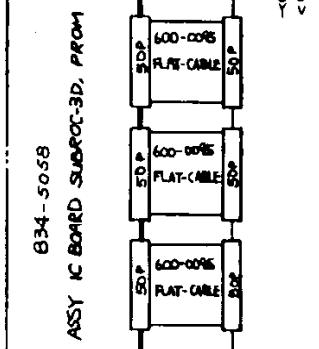
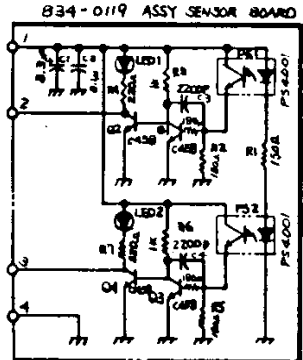
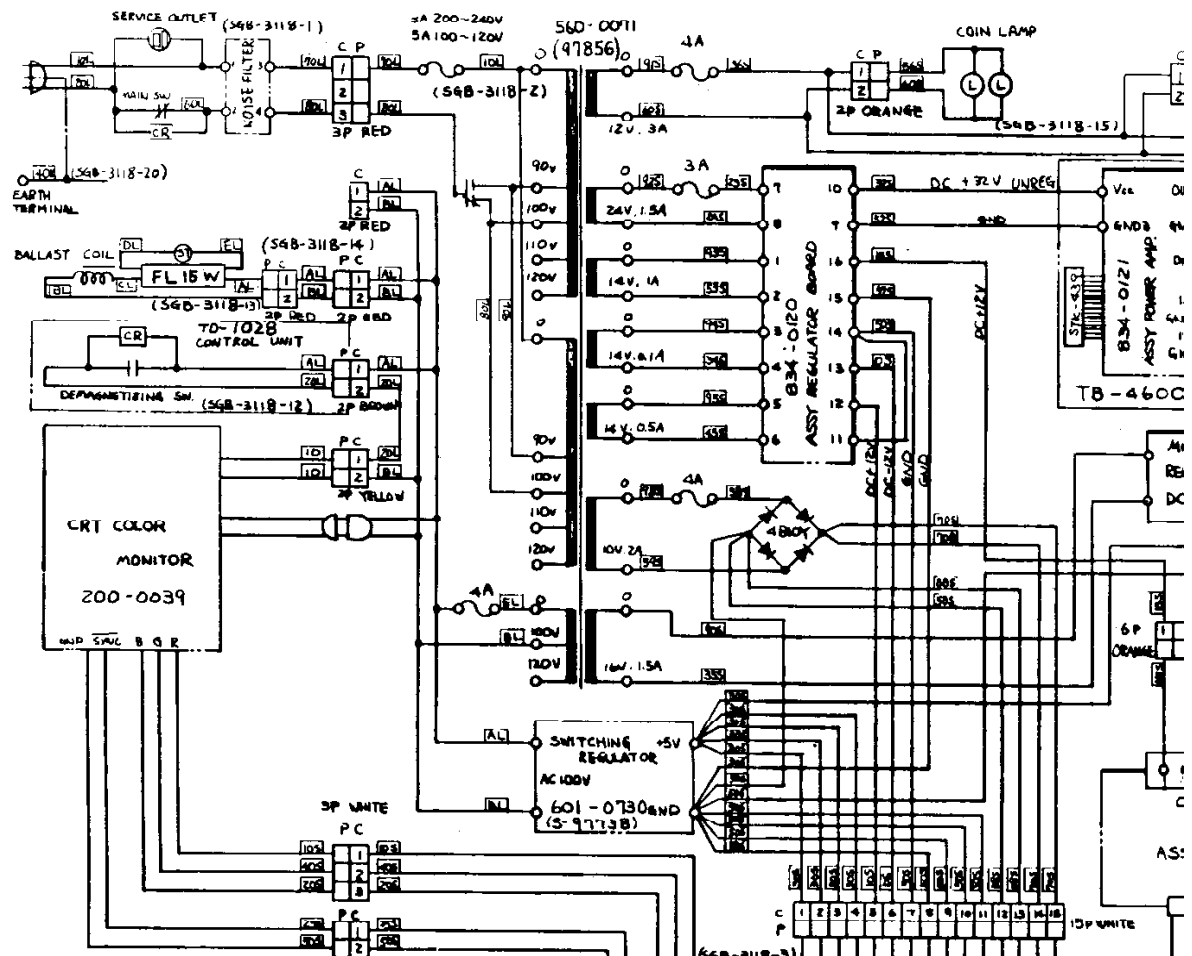

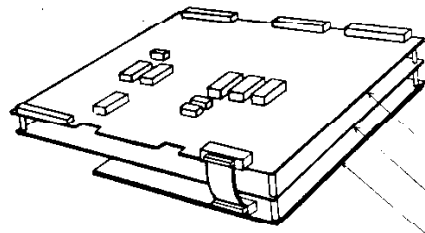
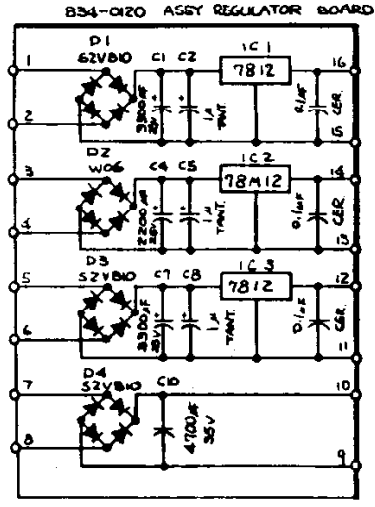
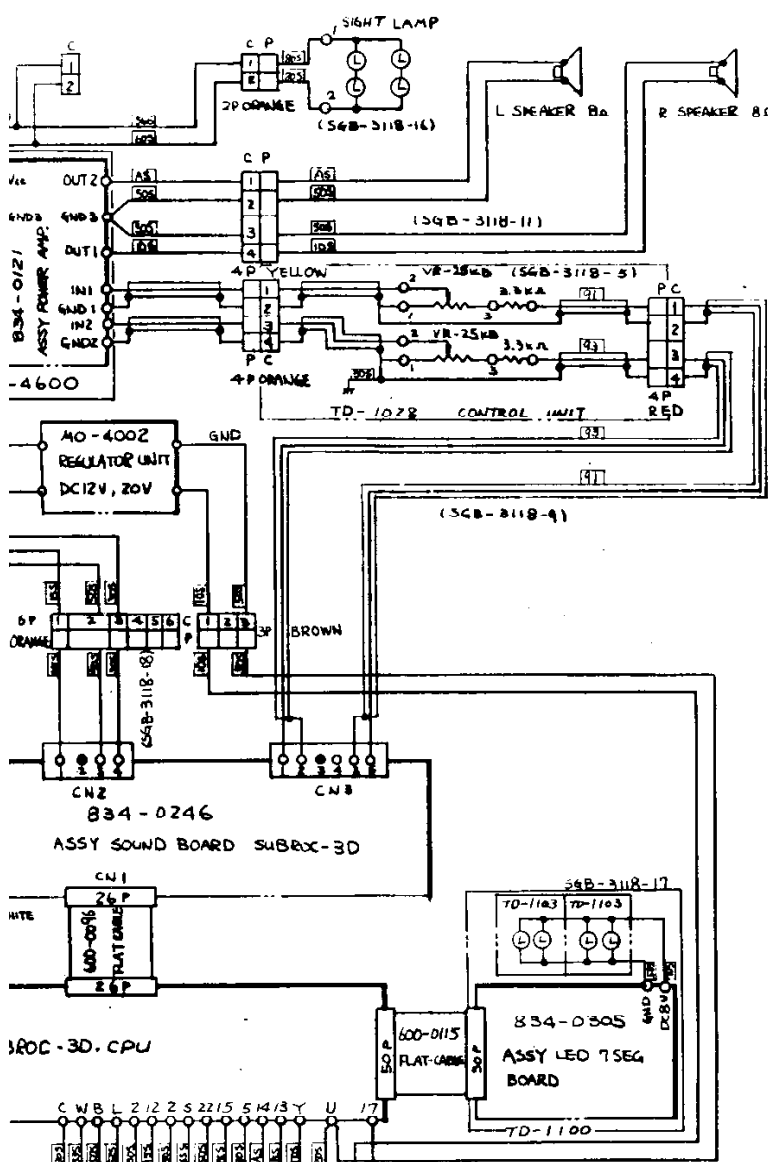
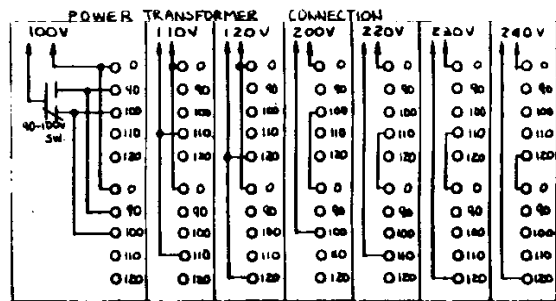

CPU BOARD 834-0358
 PROM BOARD 834-5058
 SOUND BOARD 834-0246
 ASSY IC BOARD 834-0357

14 SCHEMATIC DIAGRAM UPRIGHT TYPE

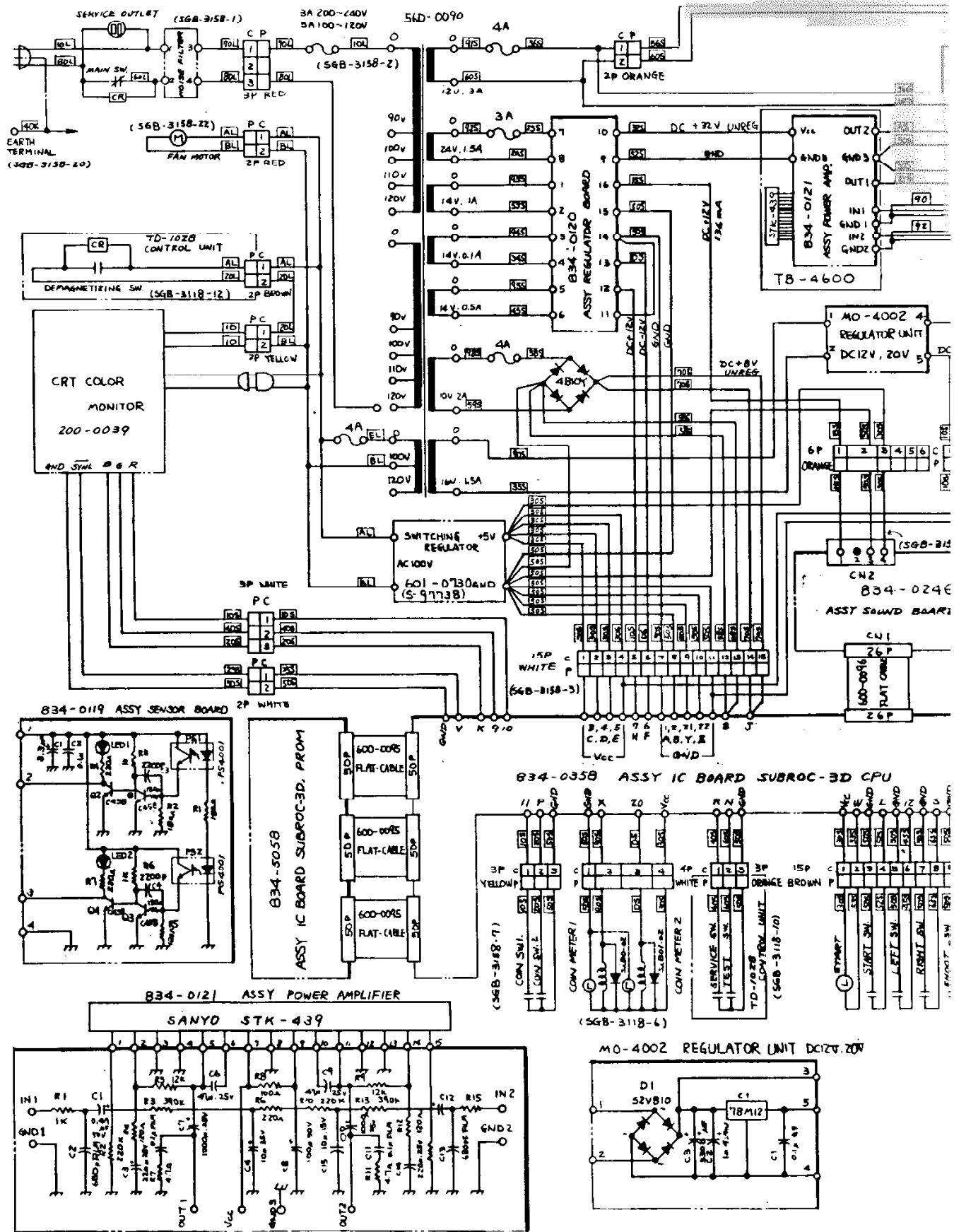

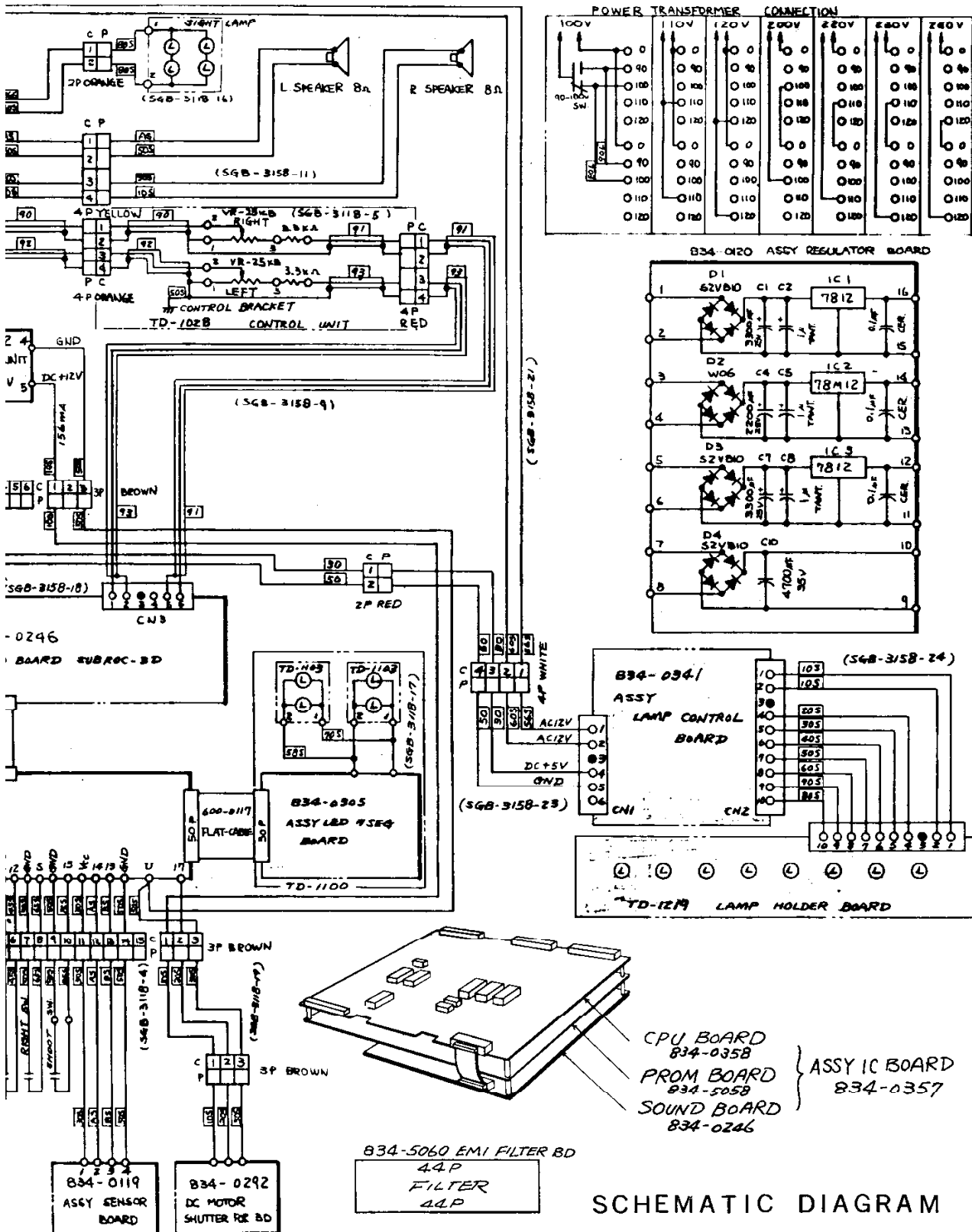

SCHMATIC DIAGRAM
COCKPIT TYPE

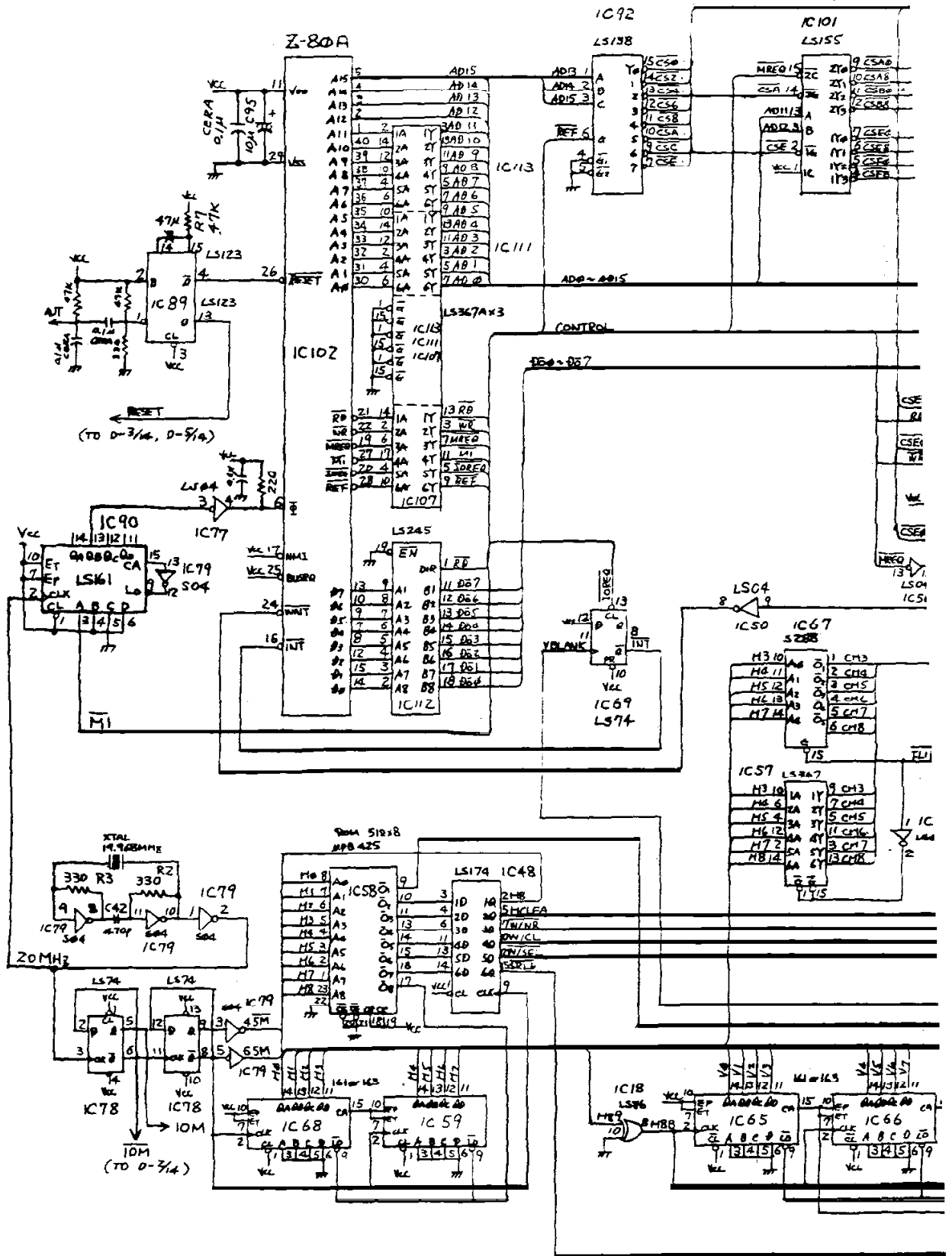

LOGIC DIAGRAM CPU D-1/14

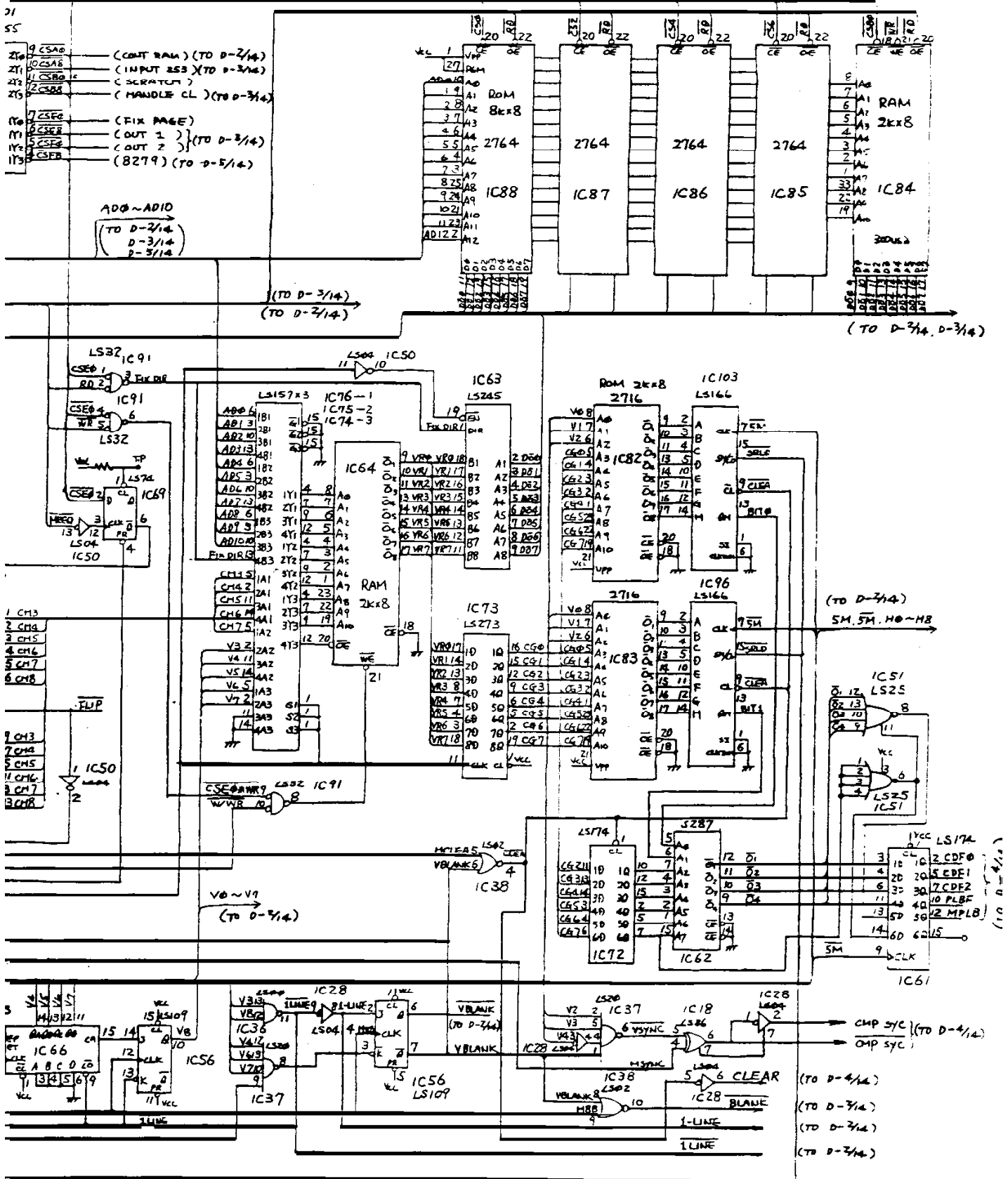

IC35-1
IC46-2
IC47-3

ROM (512x8)
MP8425

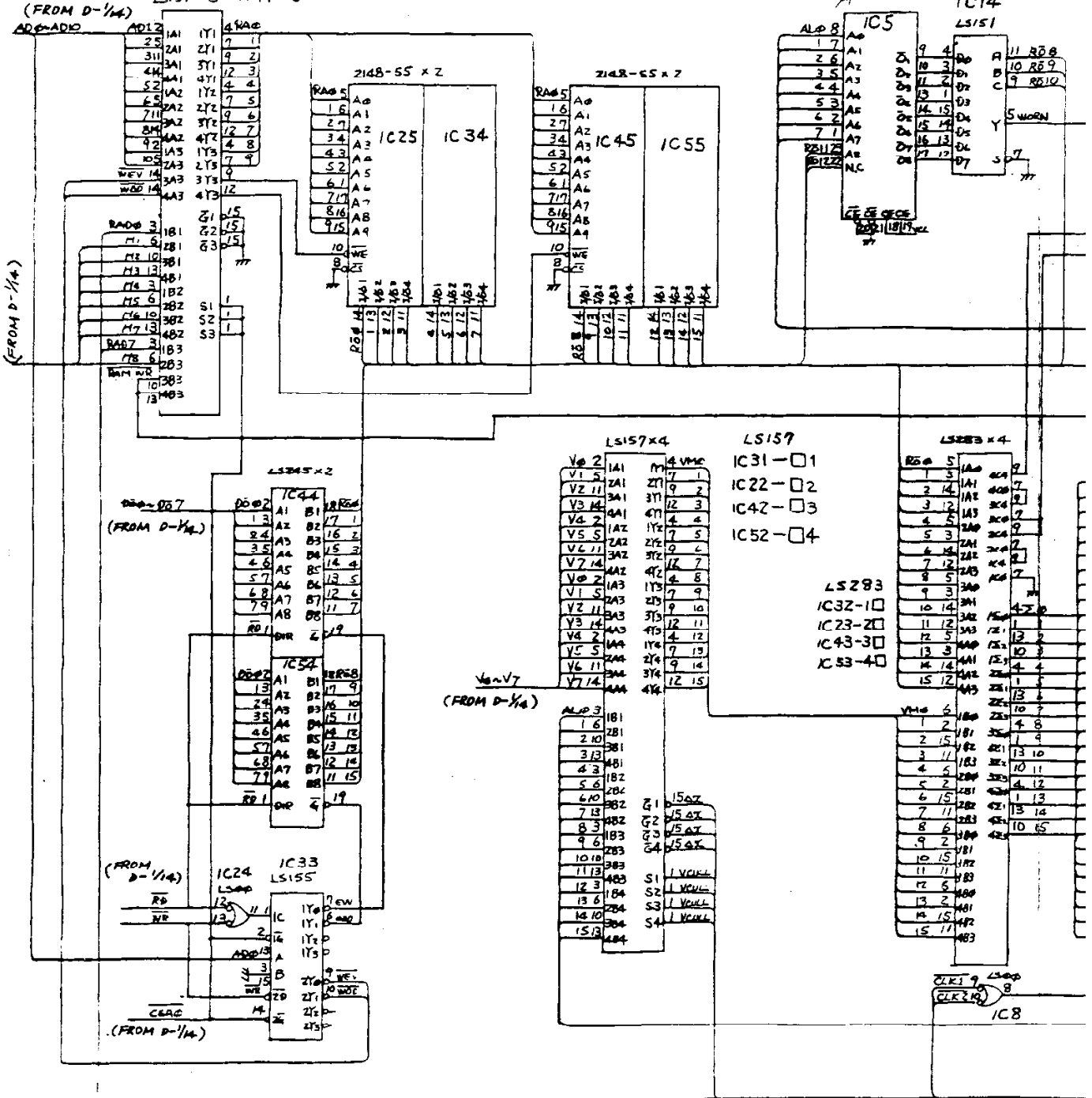

LOGIC DIAGRAM CPU D-2/14

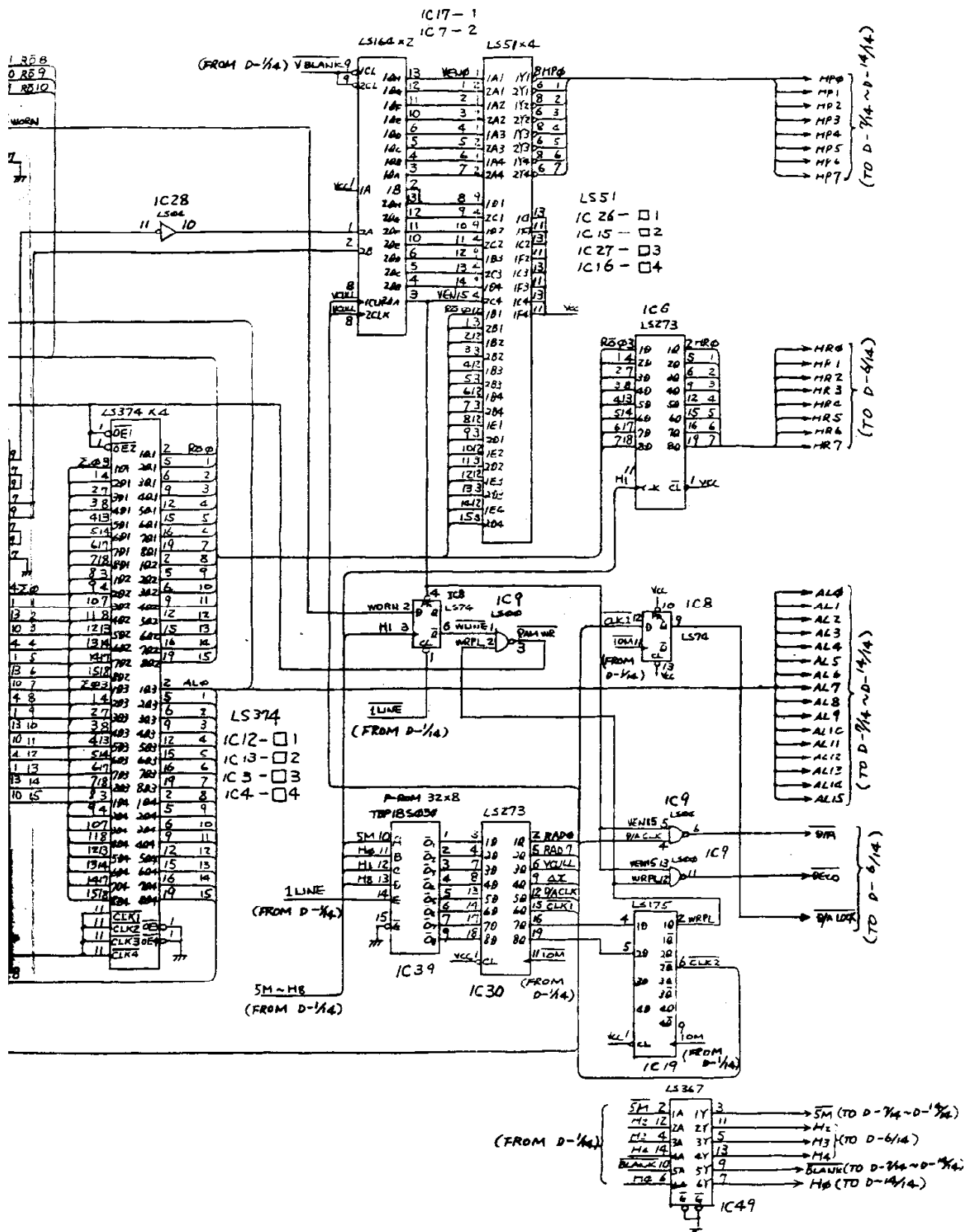

- LS 253
 IC 110 - □ 1
 IC 106 - □ 2
 IC 109 - □ 3
 IC 105 - □ 4

LS253 x 4

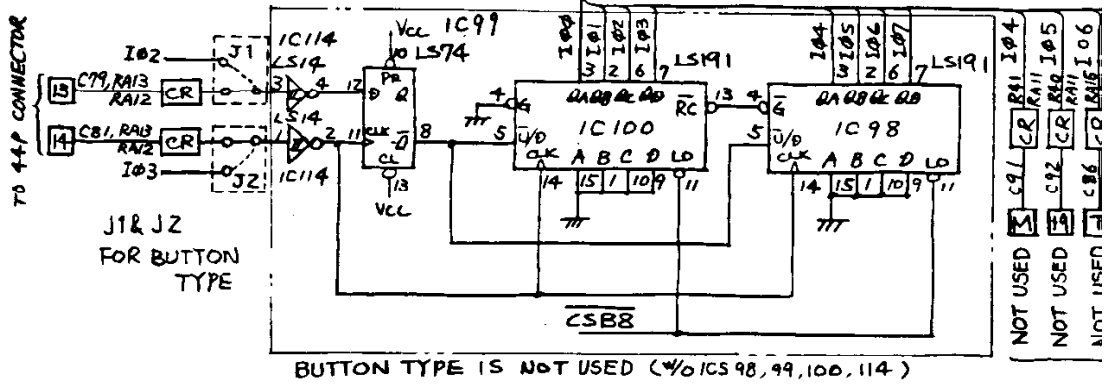
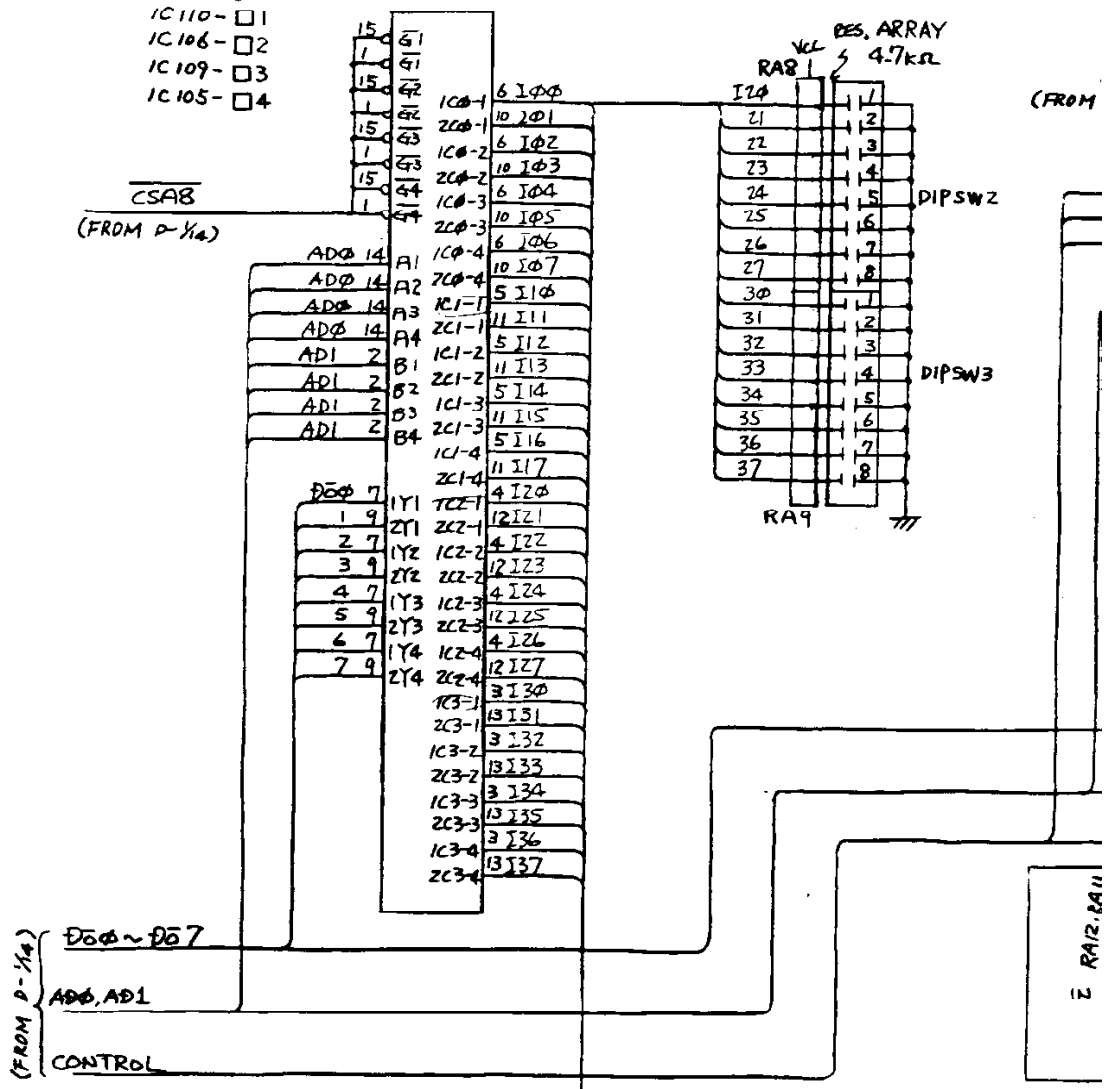

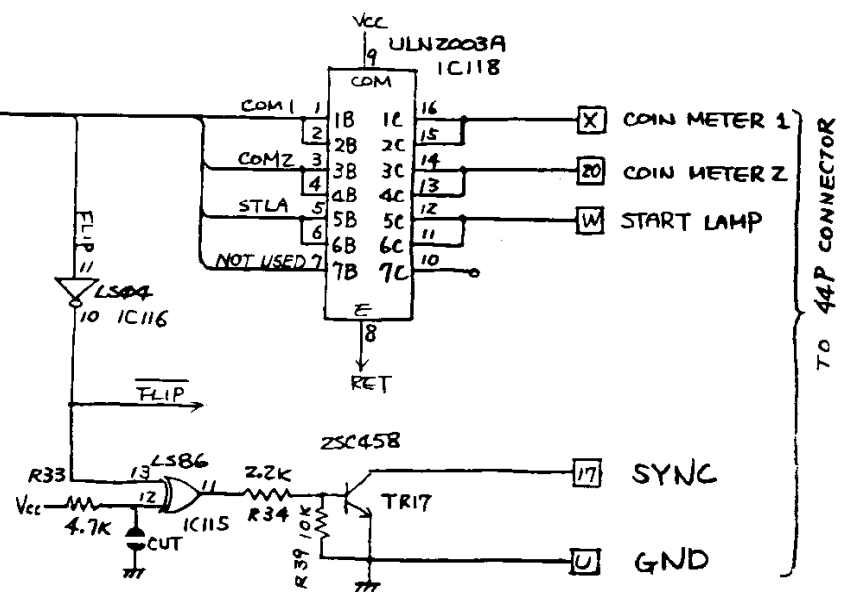
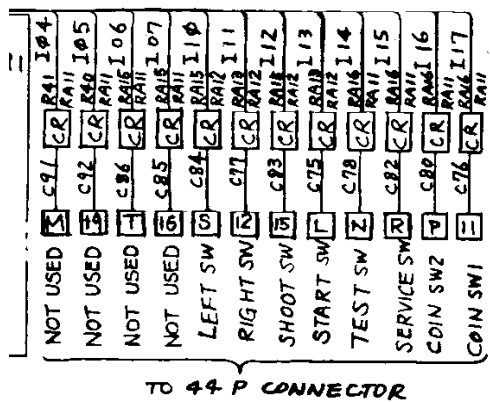
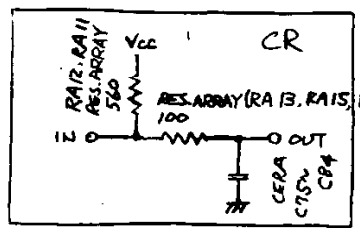
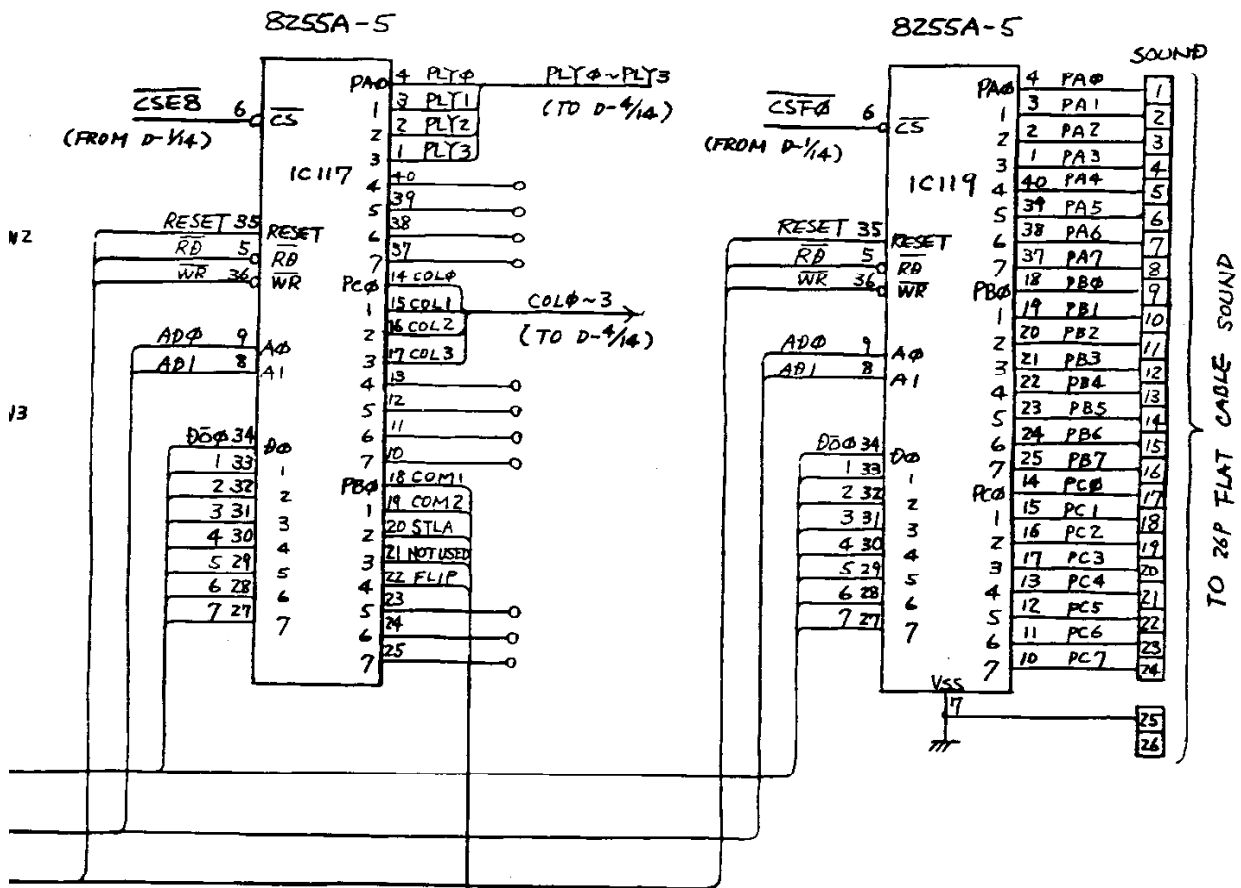

LOGIC DIAGRAM CPU D-4/14

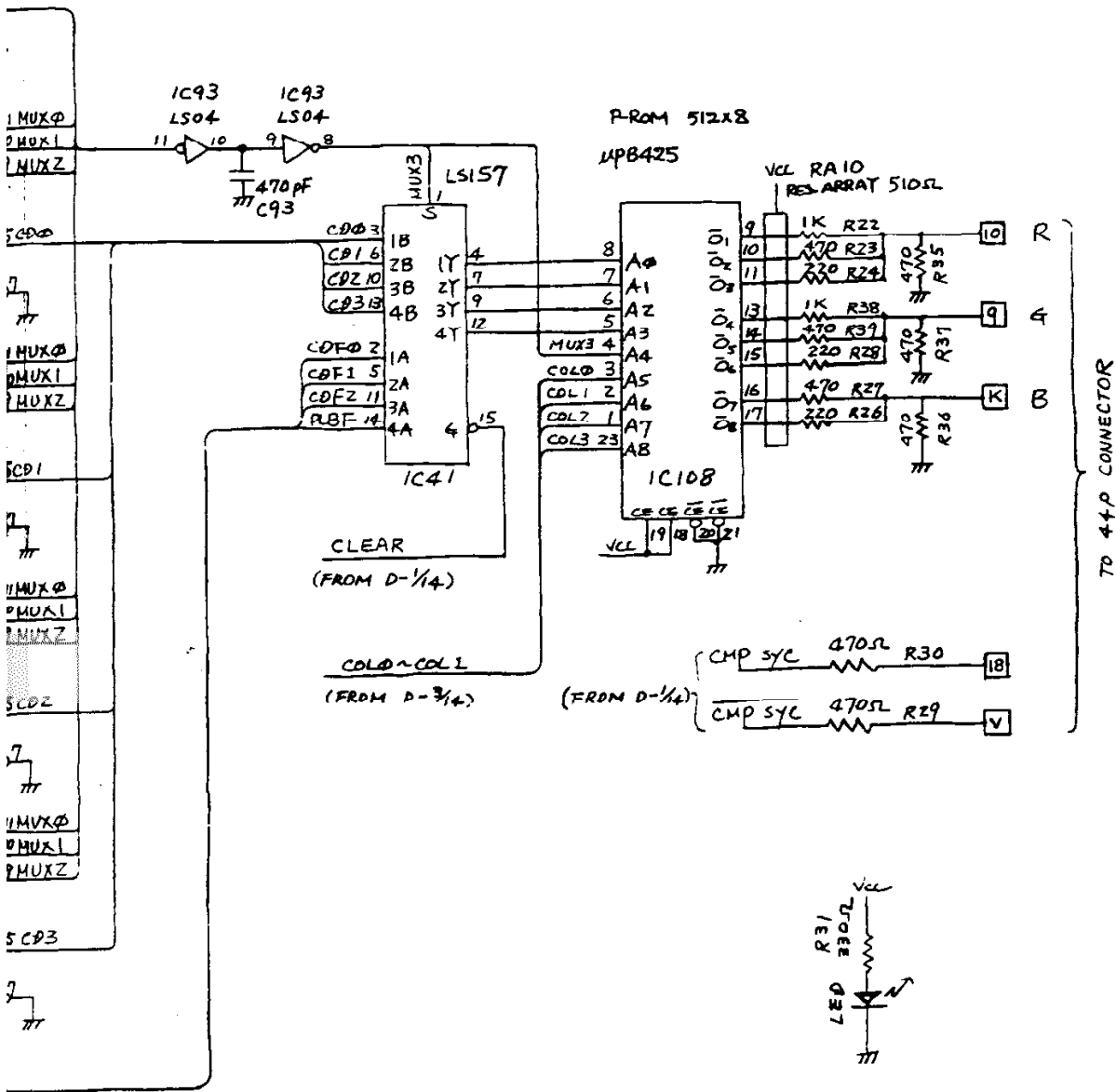

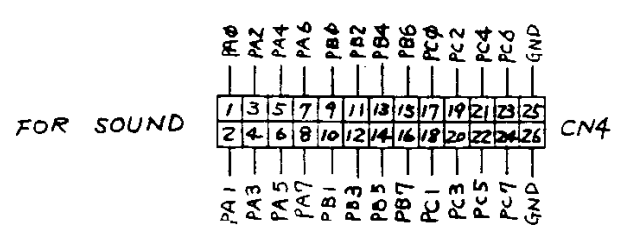
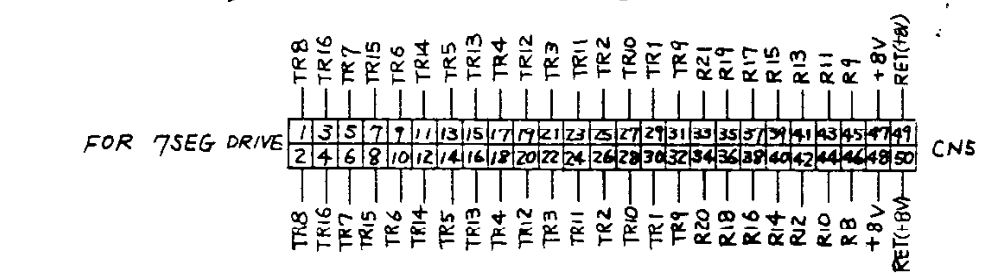
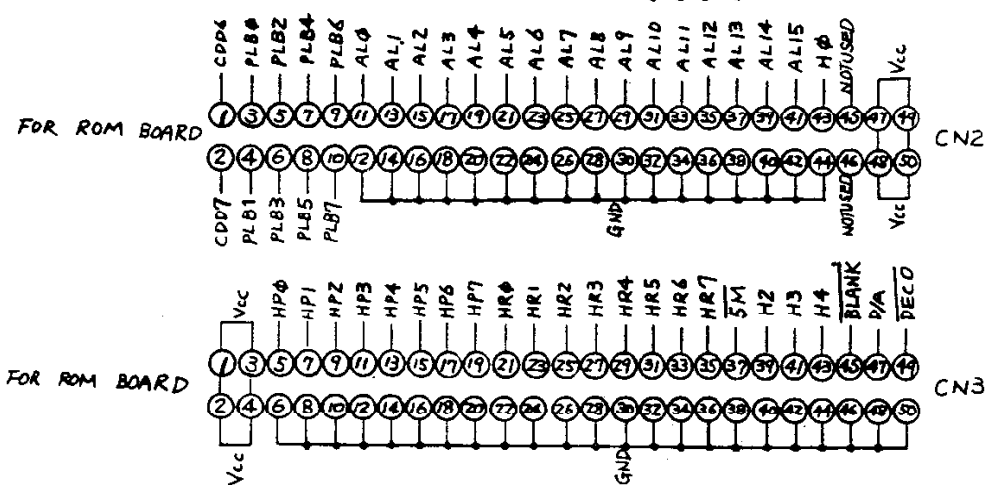
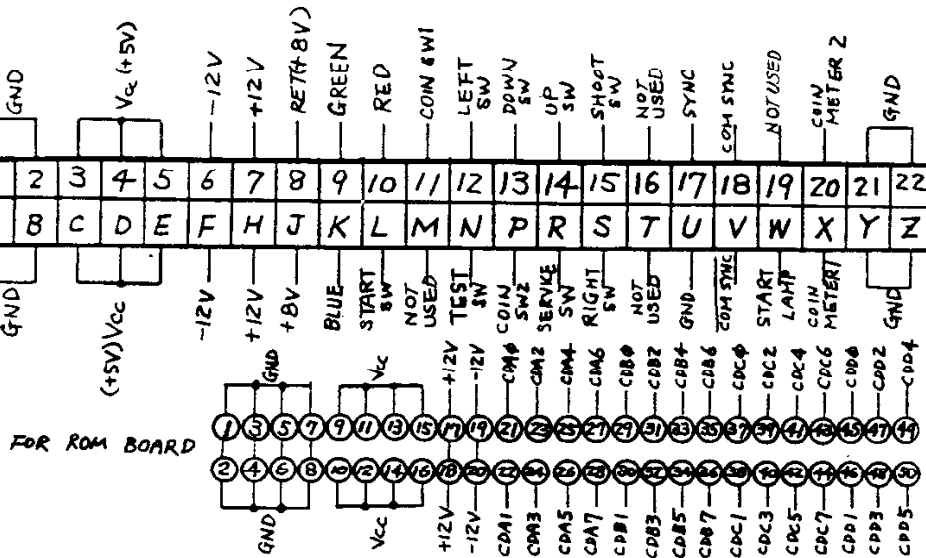
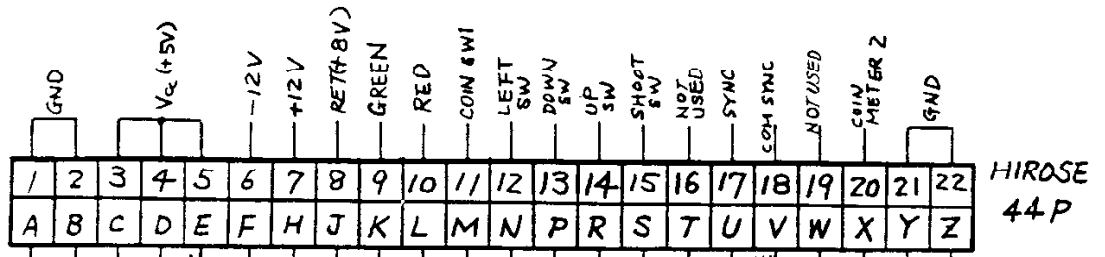

LOGIC DIAGRAM CPU D-5/14

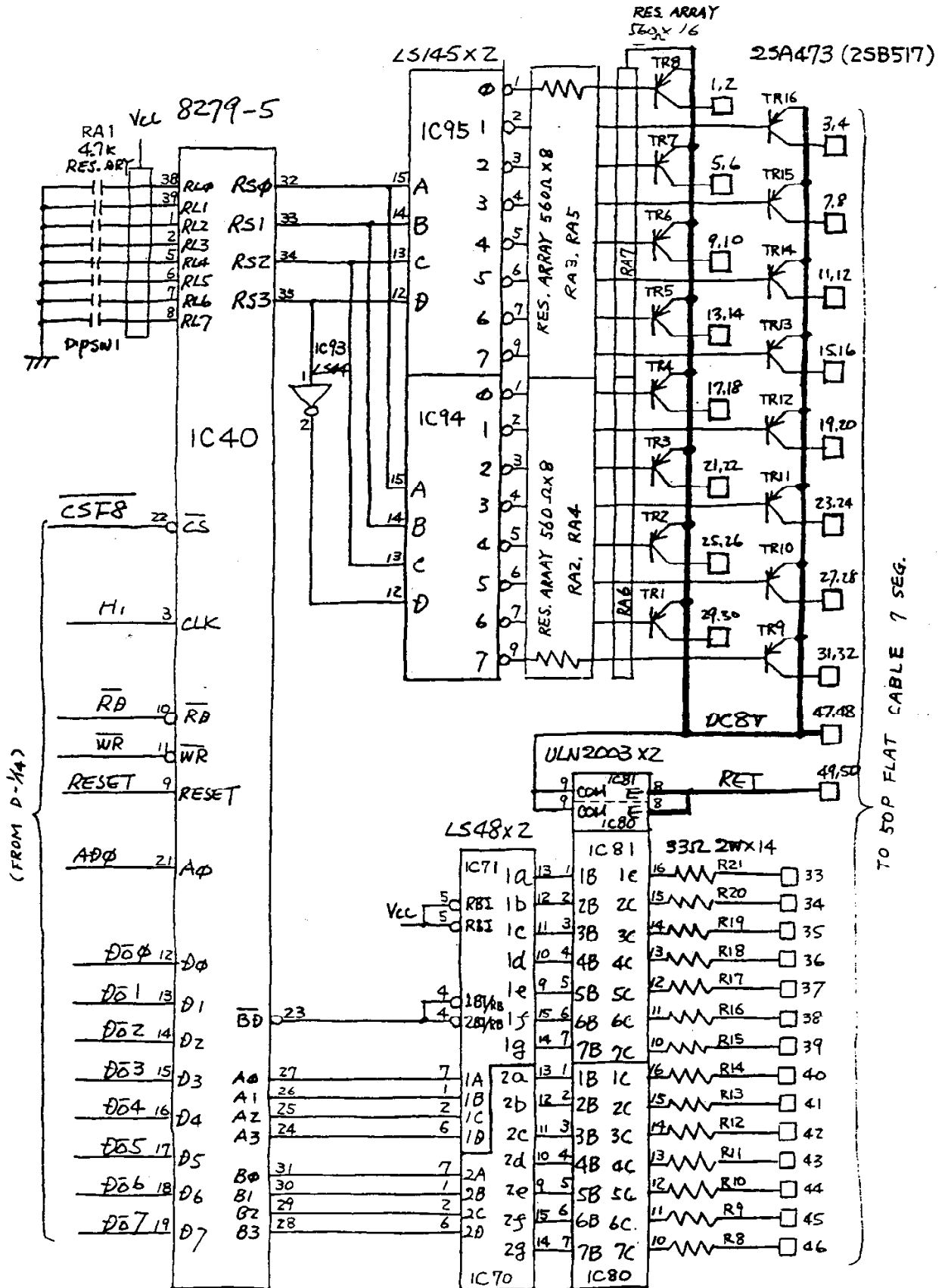

TO 50P FLAT CABLE 7 SEG.

(FROM D-1/4)

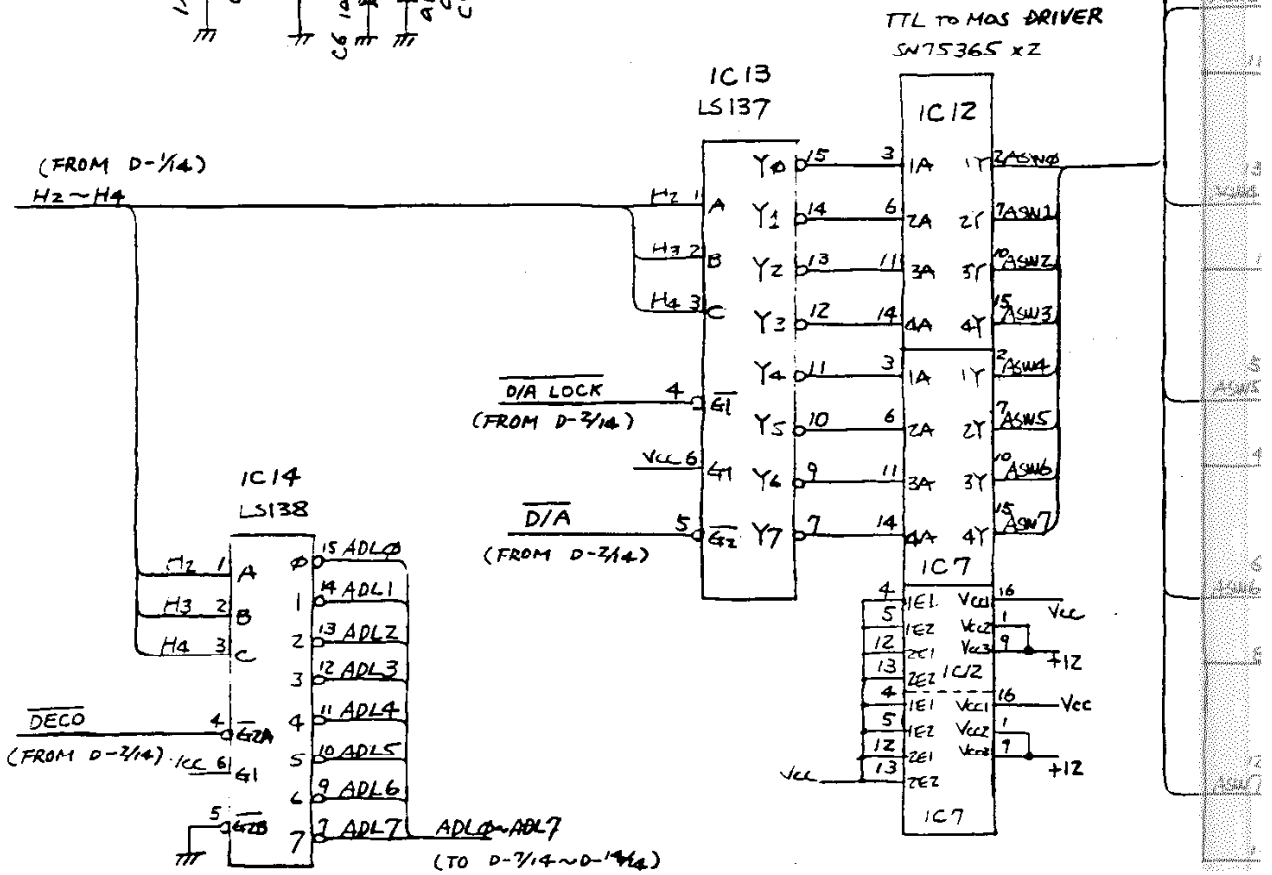
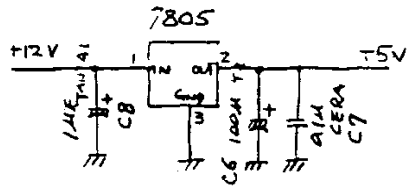
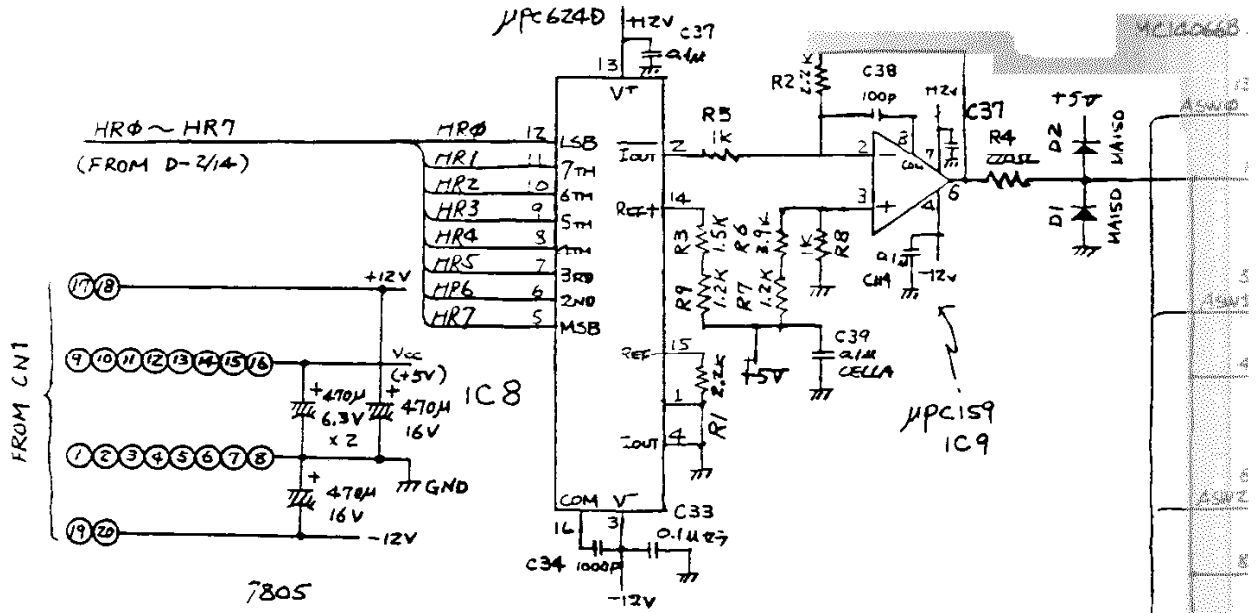

LOGIC DIAGRAM ROM D-6/14

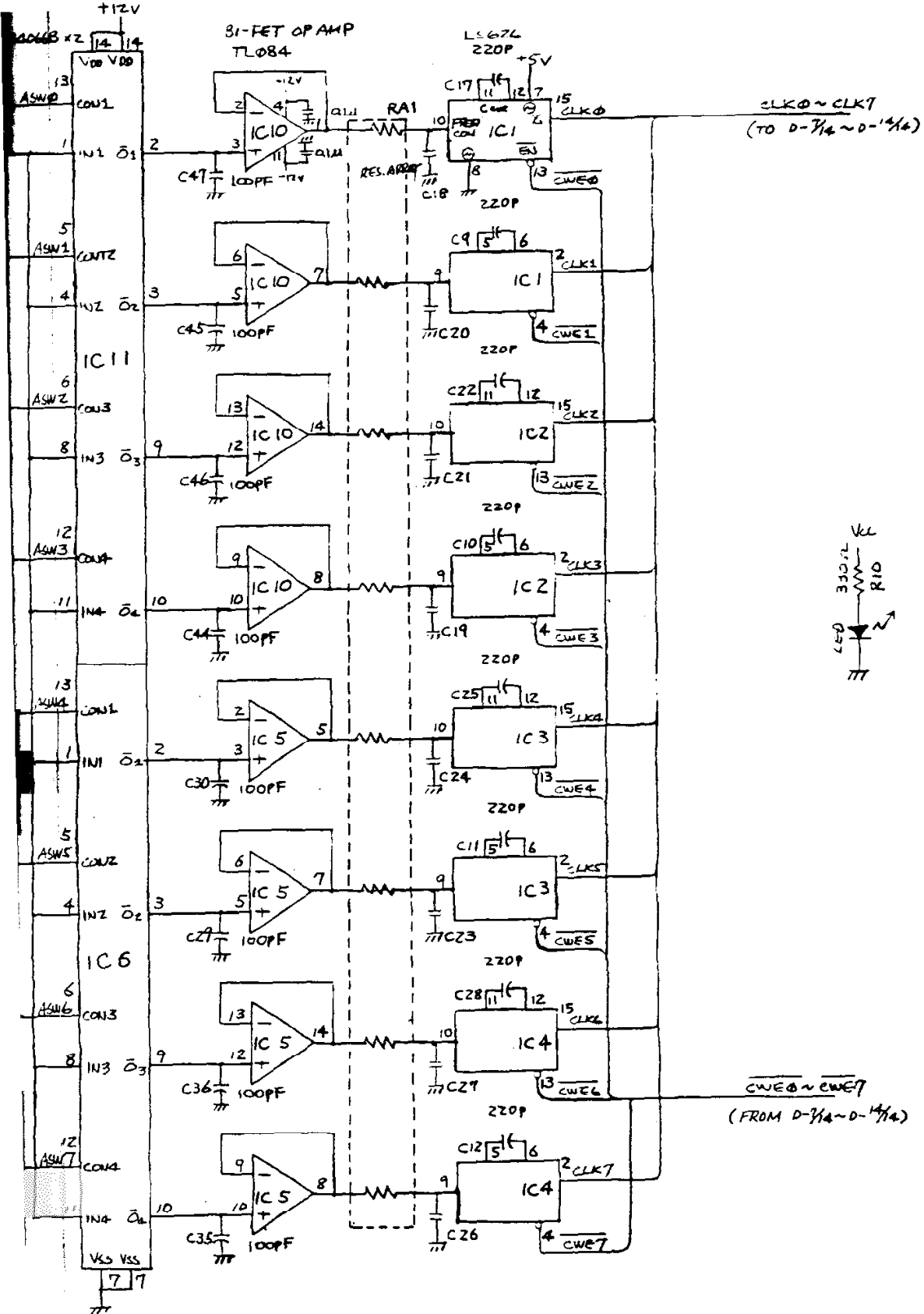

LEVEL Φ

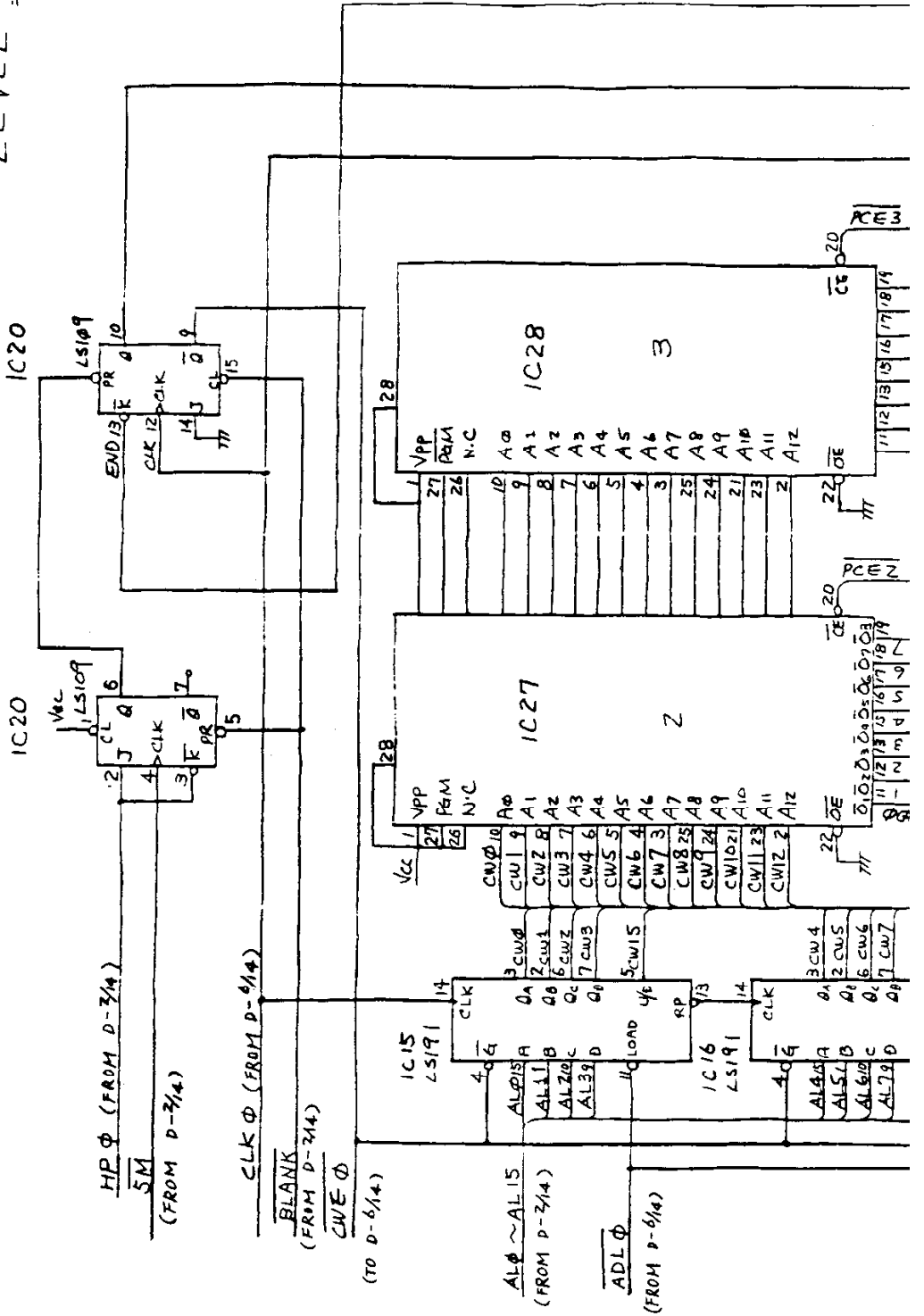

LOGIC DIAGRAM ROM D-7/14

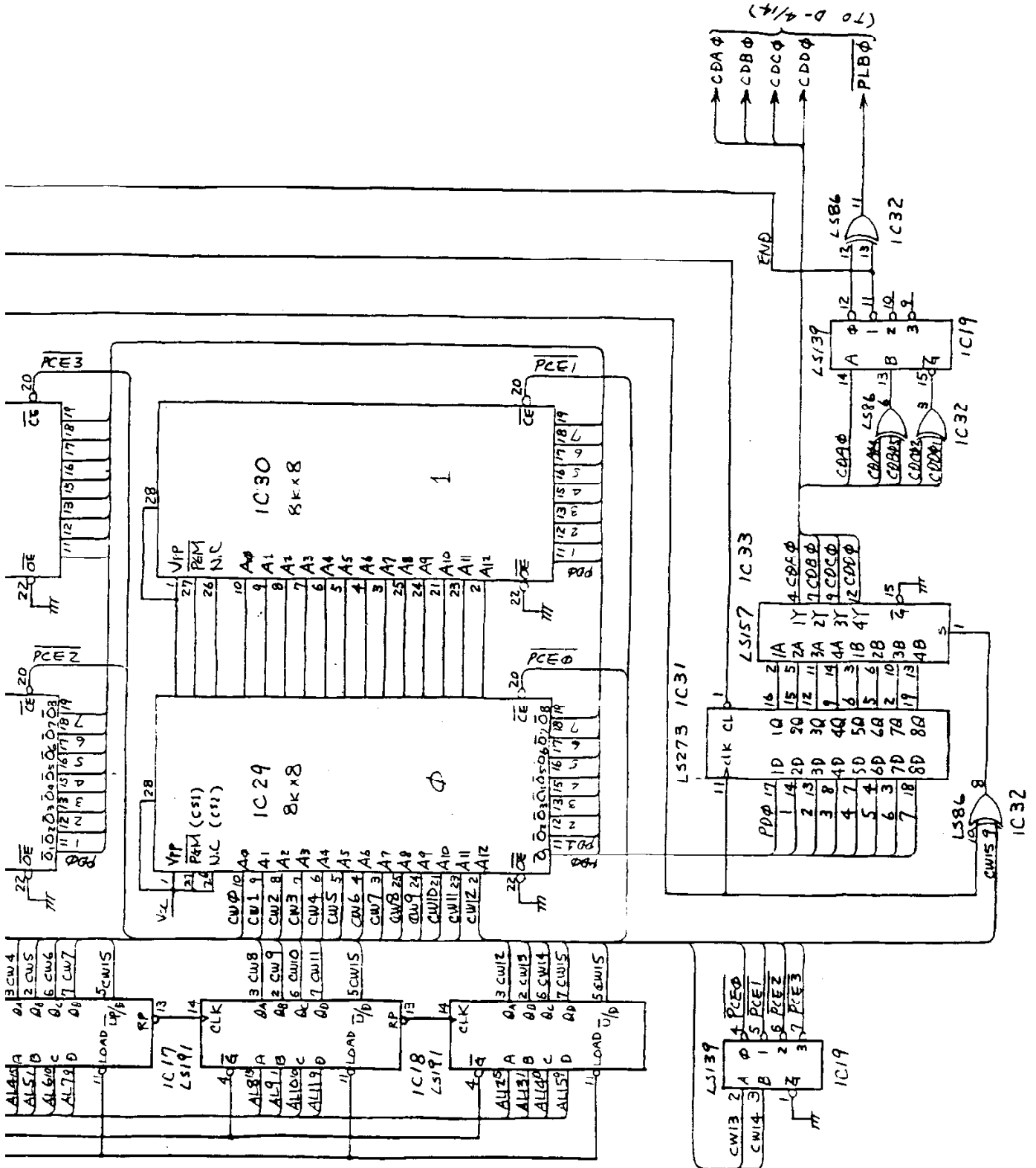

LEVEL 1

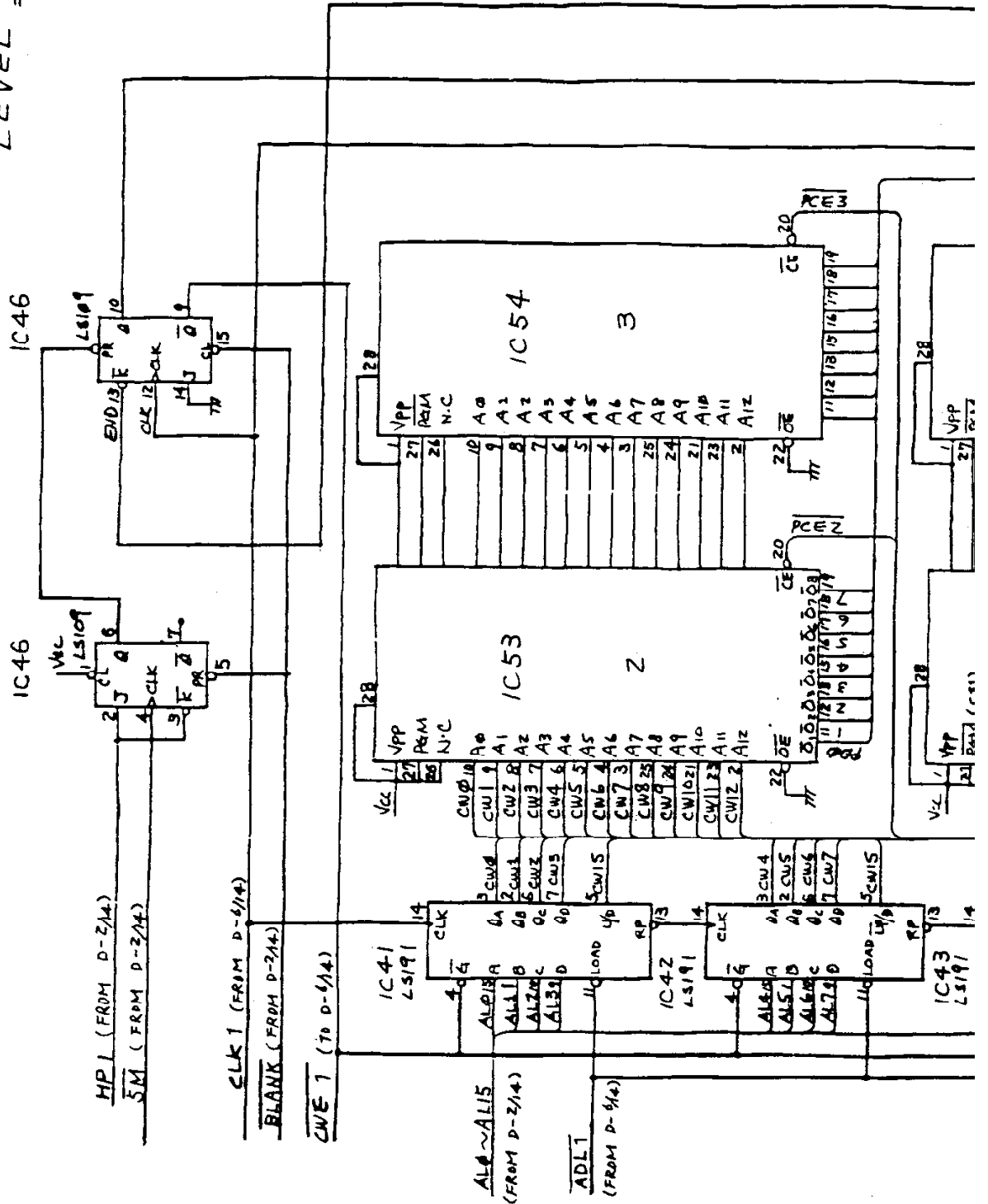

LOGIC DIAGRAM ROM D-8/14

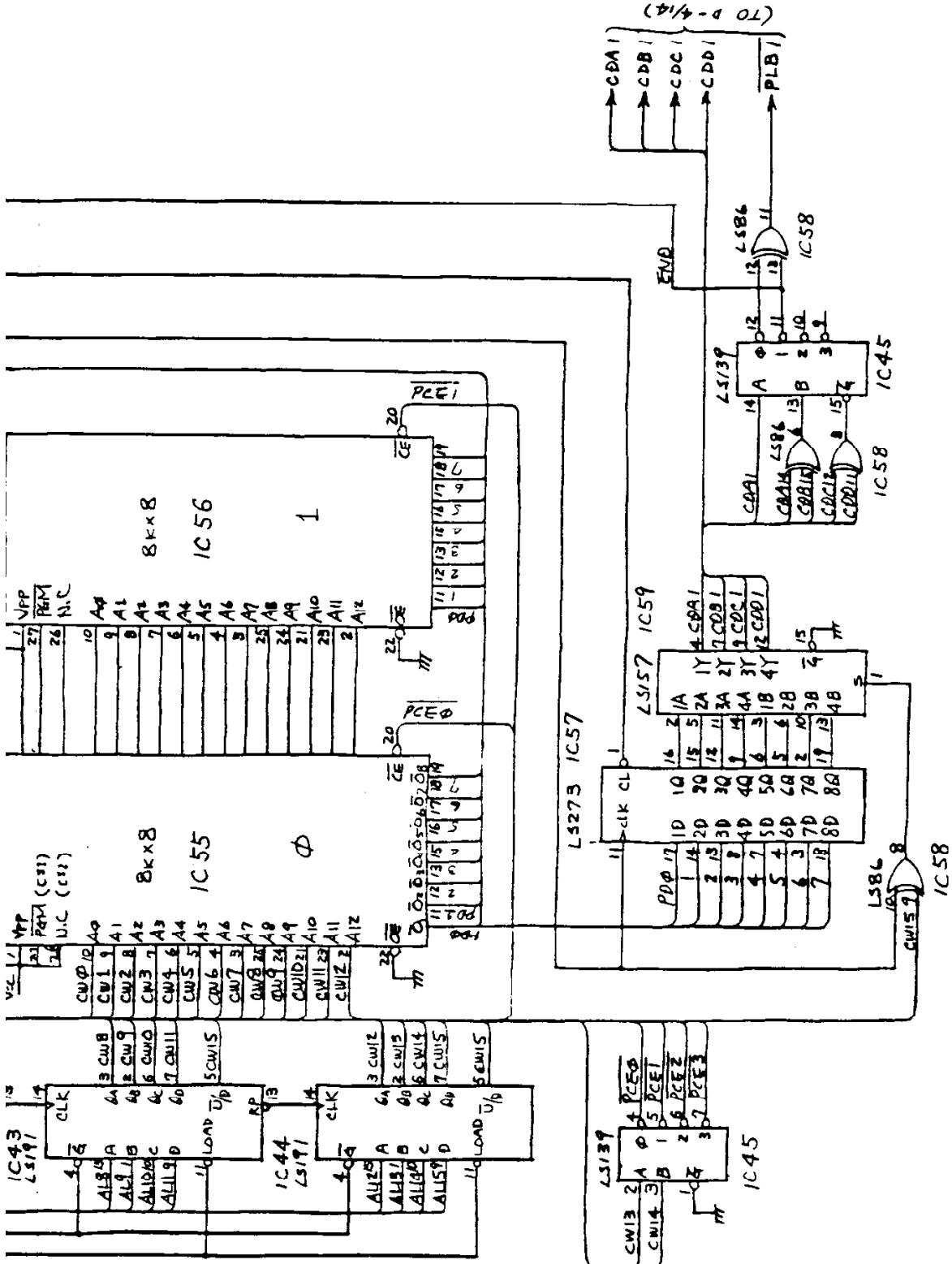

(TO D-4/14)

LEVEL 2

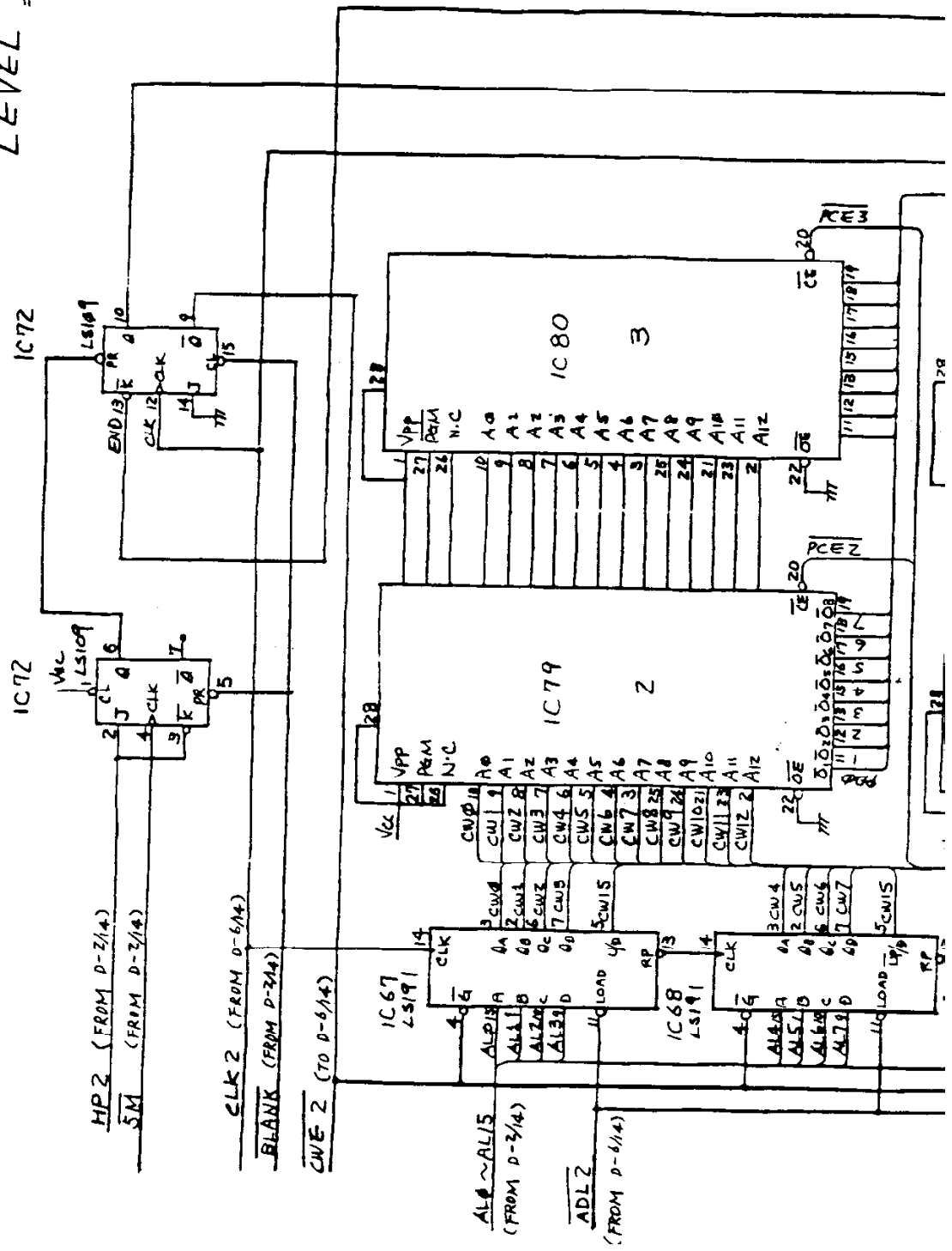

LOGIC DIAGRAM ROM D-9/14

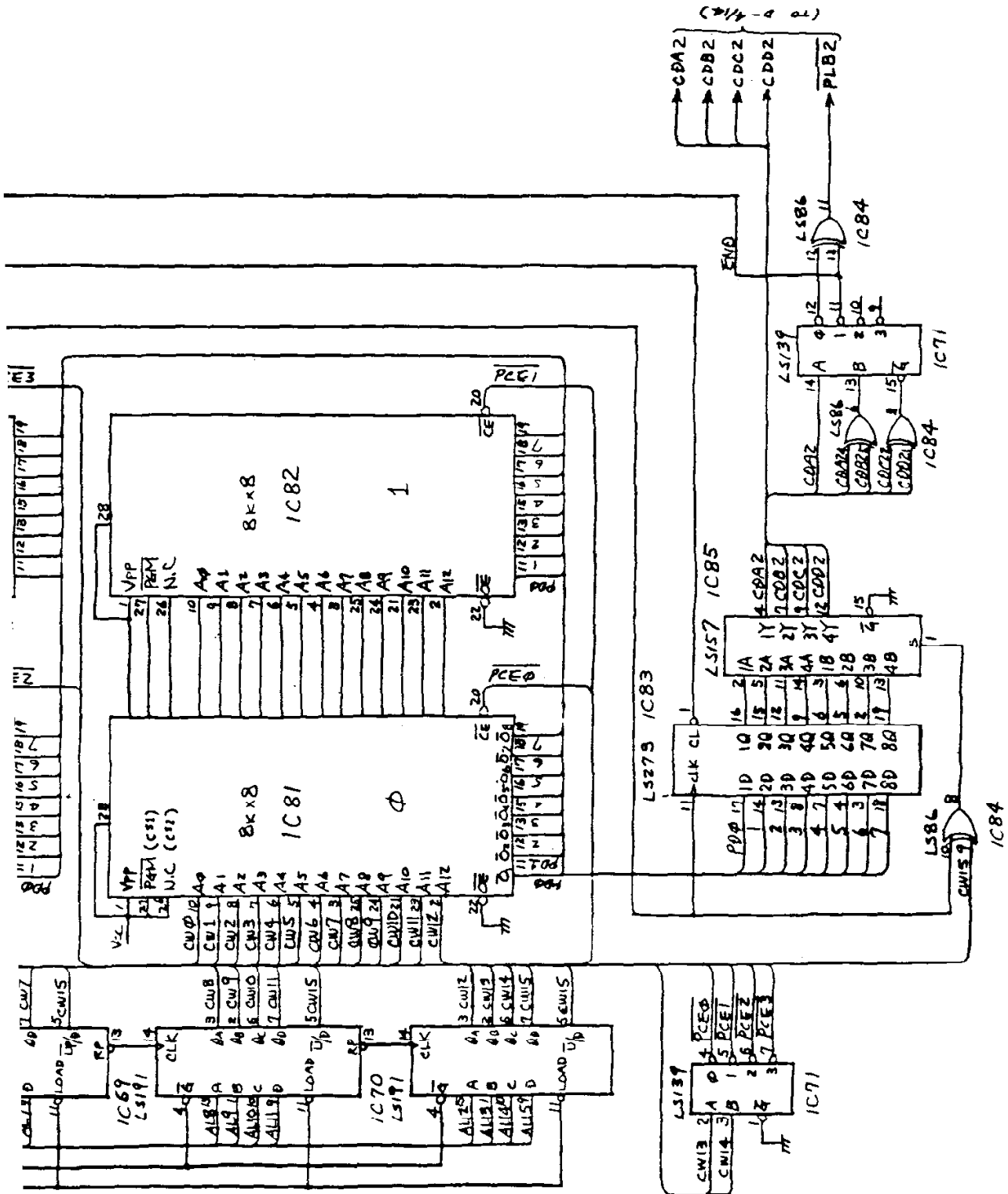

LEVEL 3

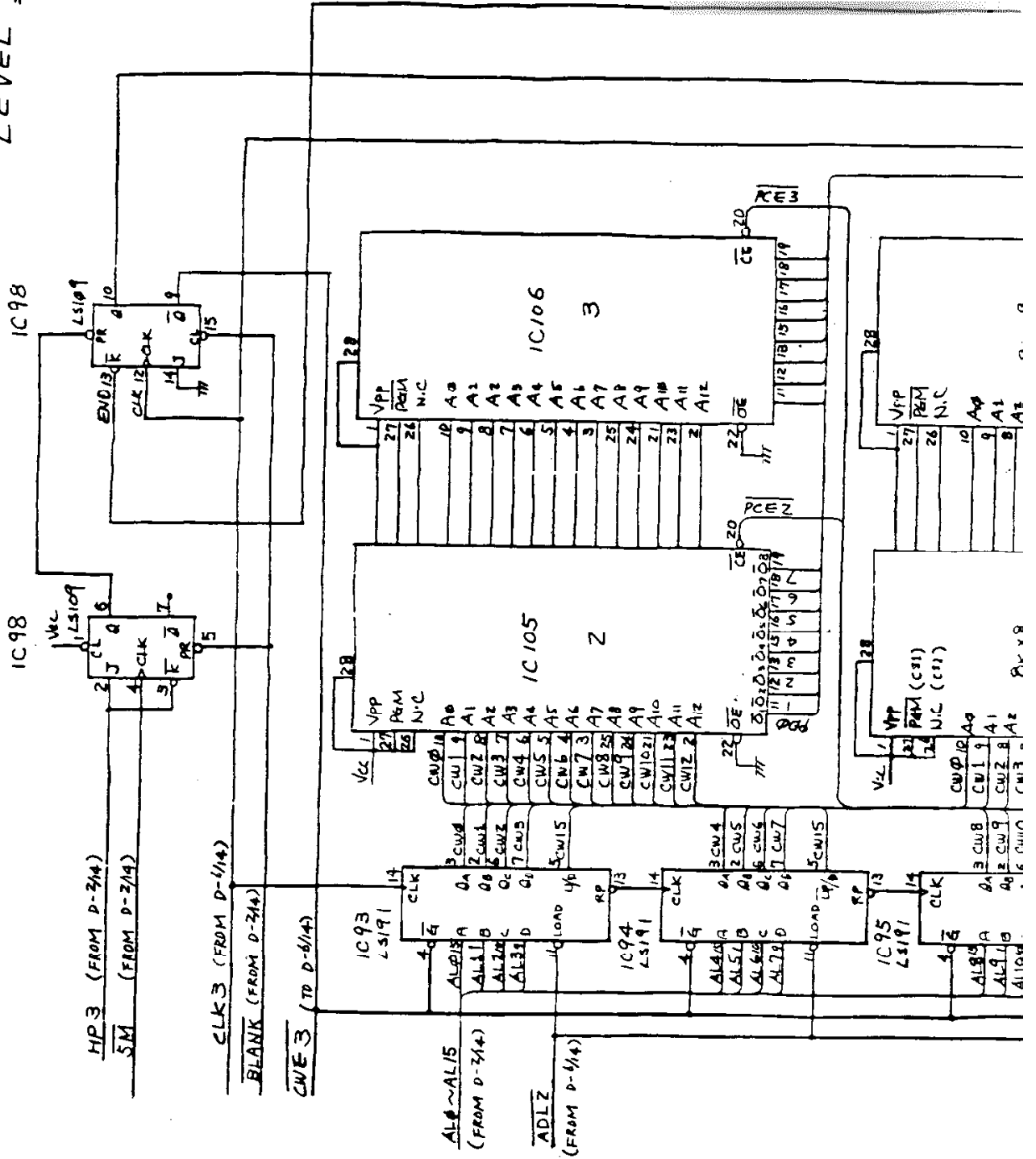

LEVEL 4

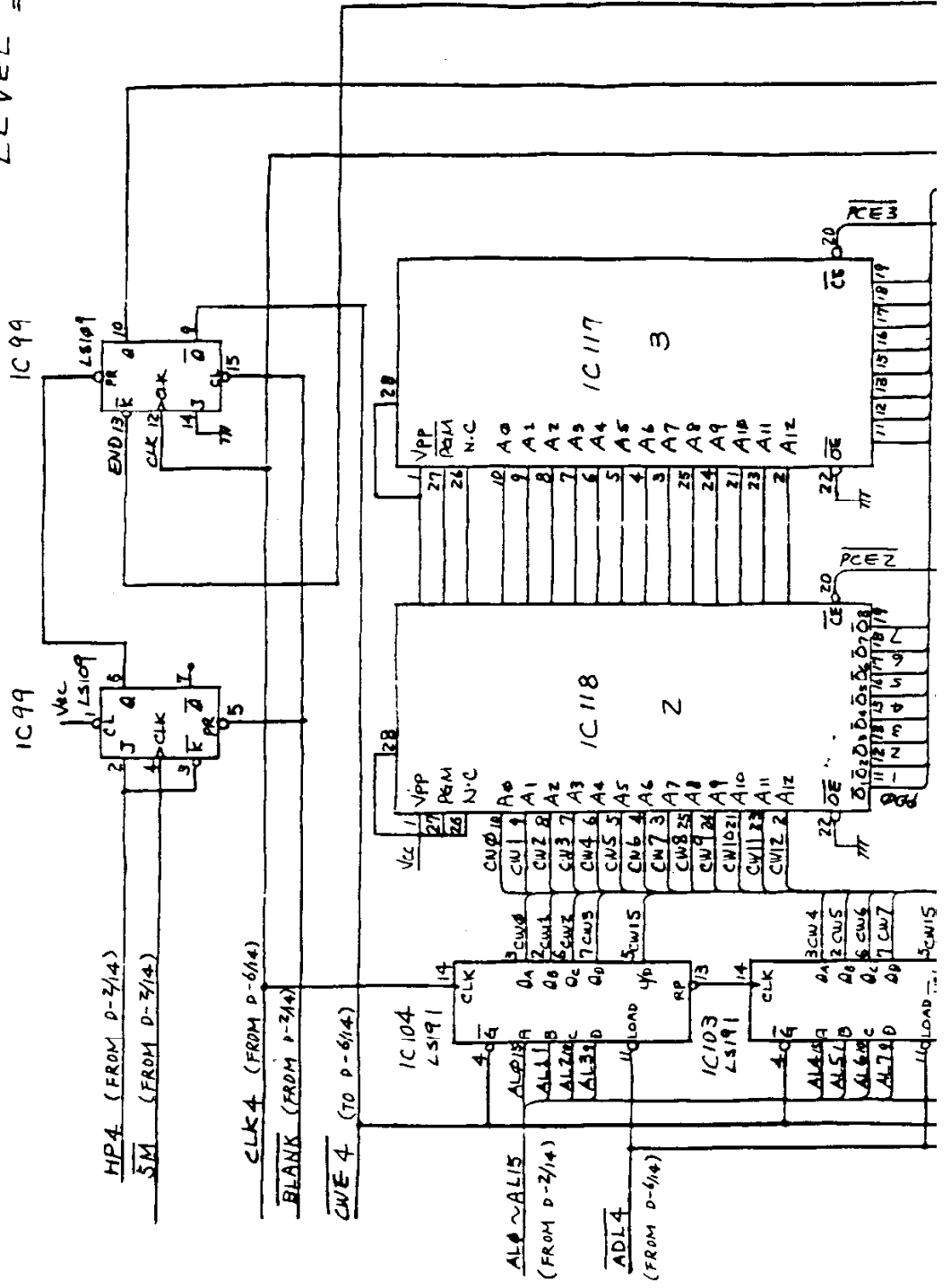

LOGIC DIAGRAM ROM D-11/14

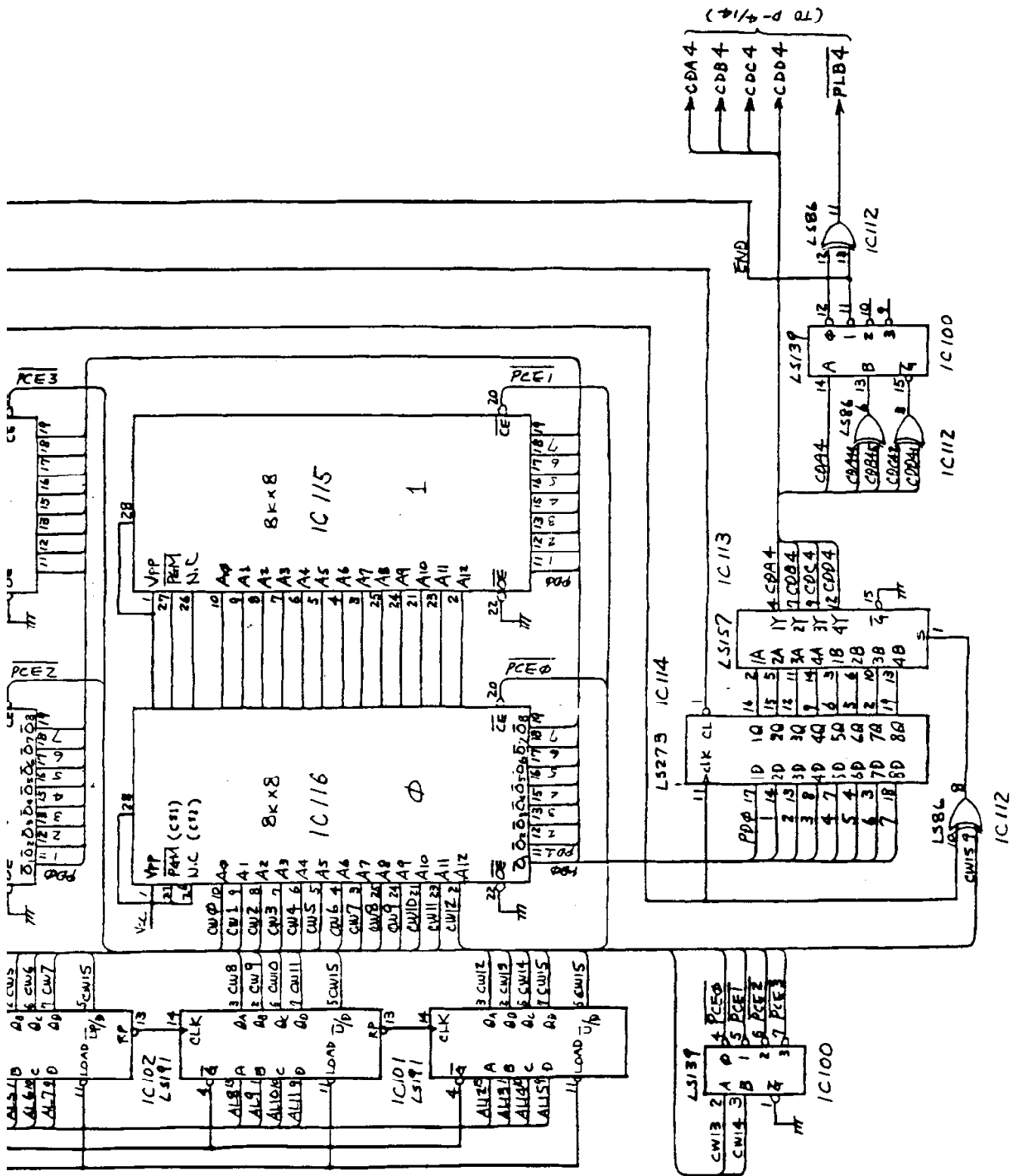

LOGIC DIAGRAM ROM D-12/14

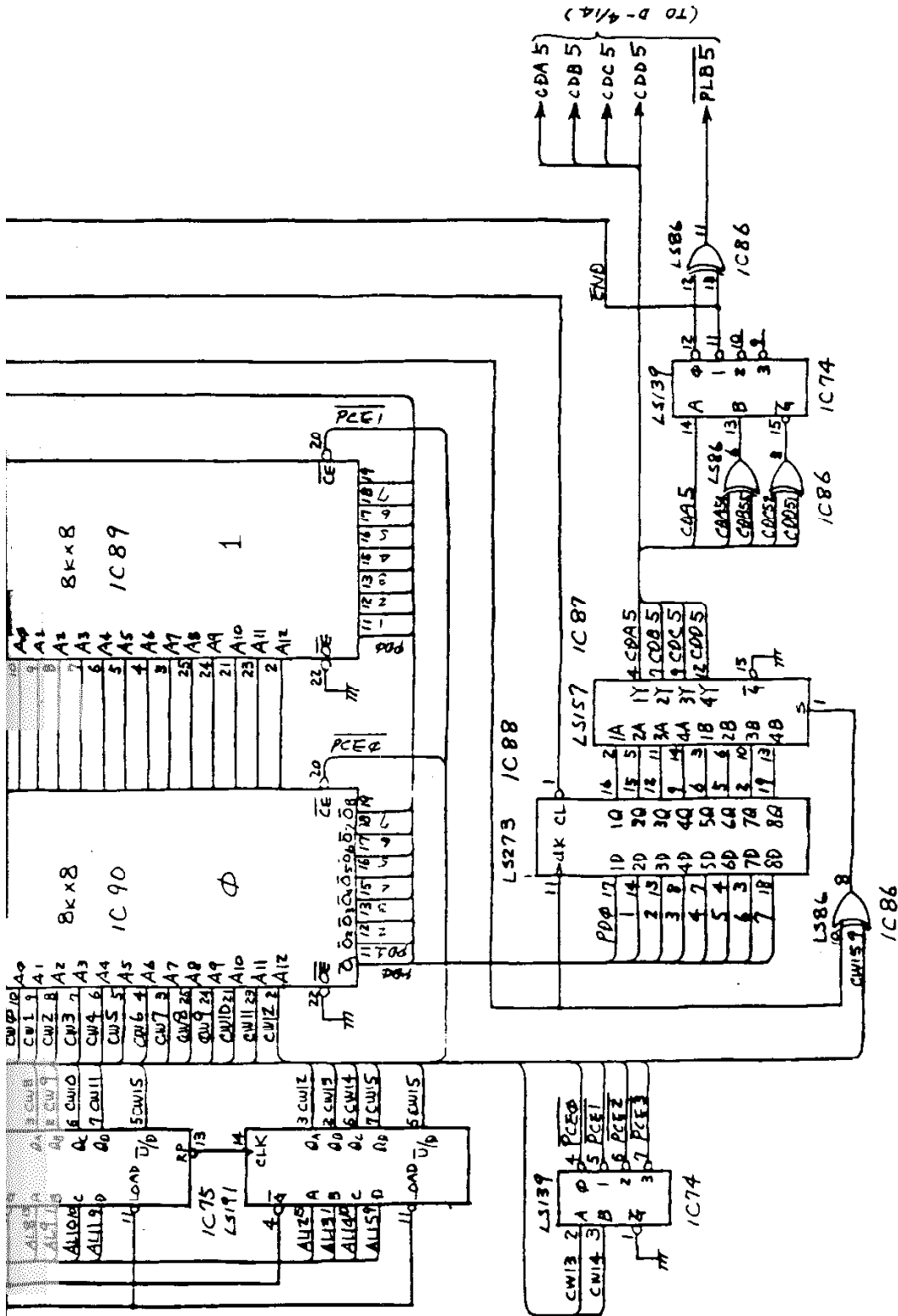

(TO D-4/4)

LEVEL 6

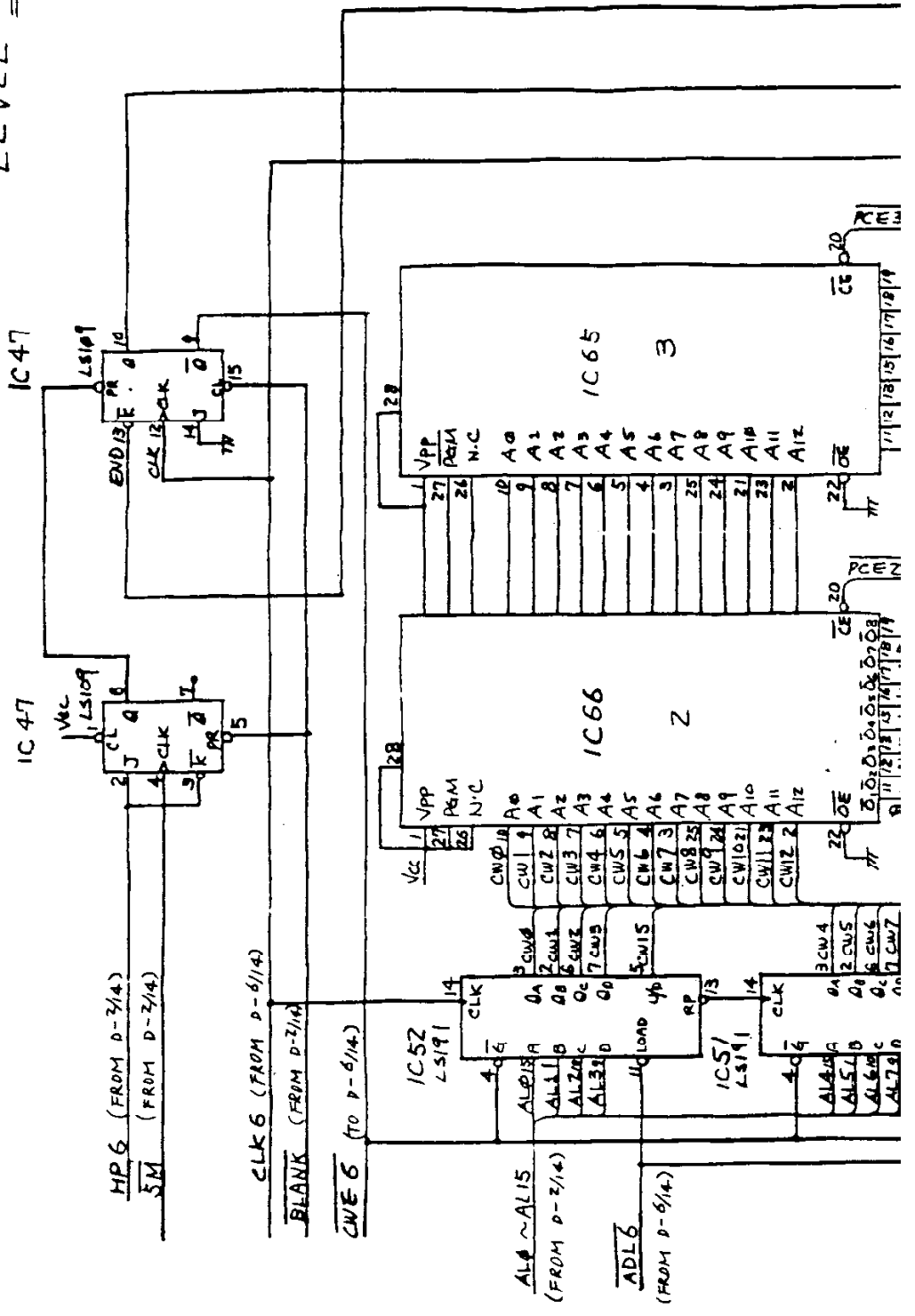

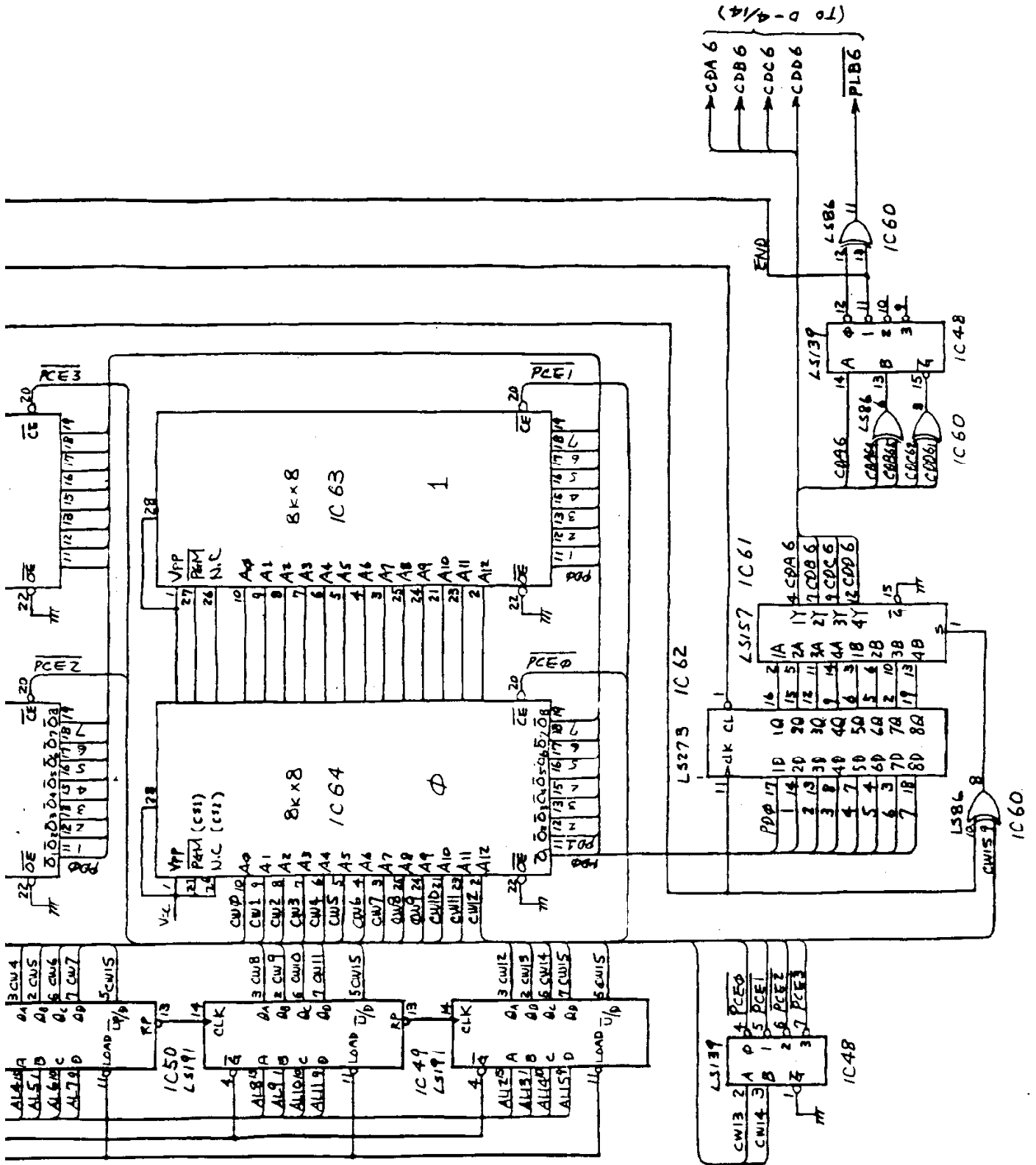

LEVEL 7

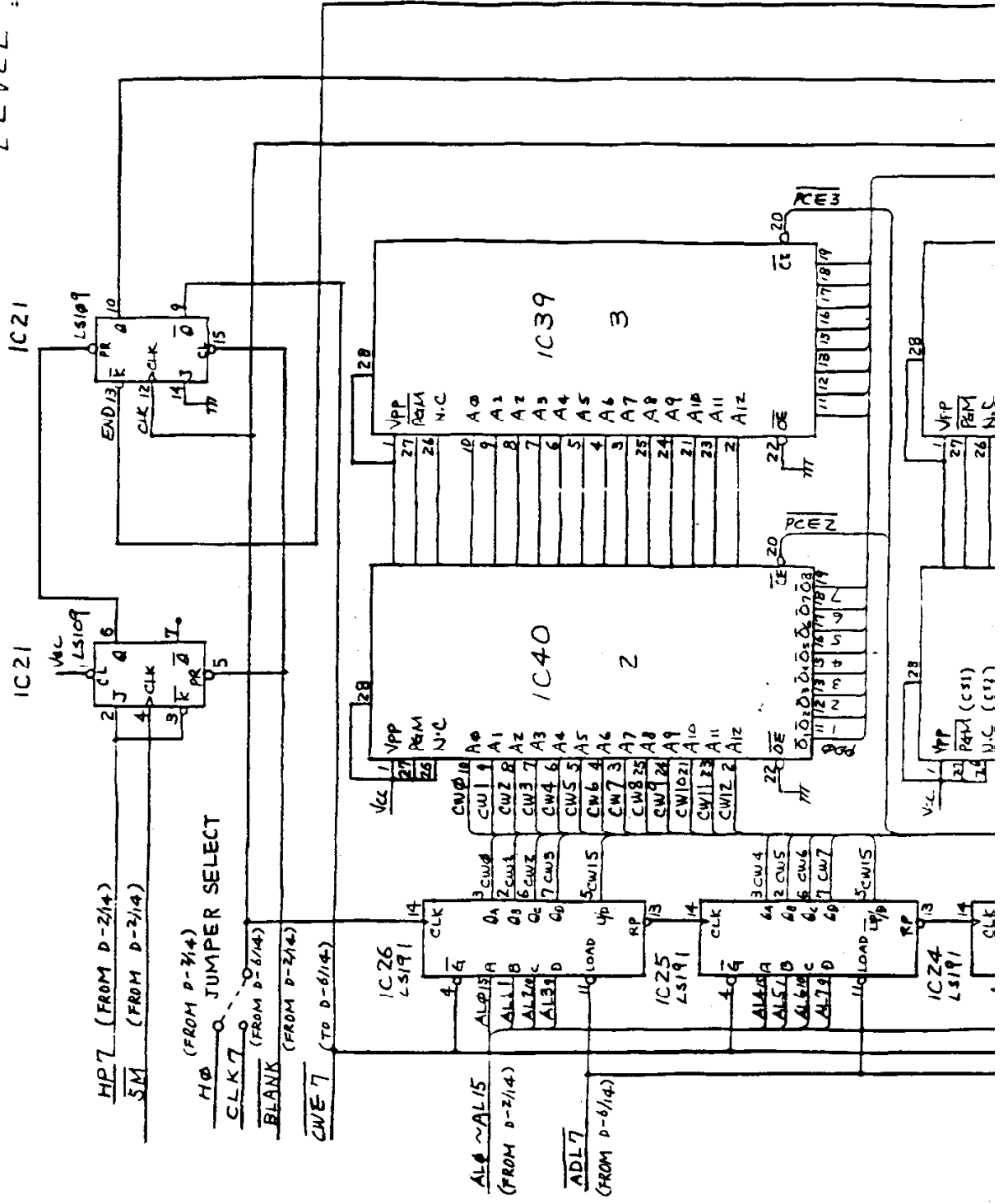

LOGIC DIAGRAM ROM D-14/14

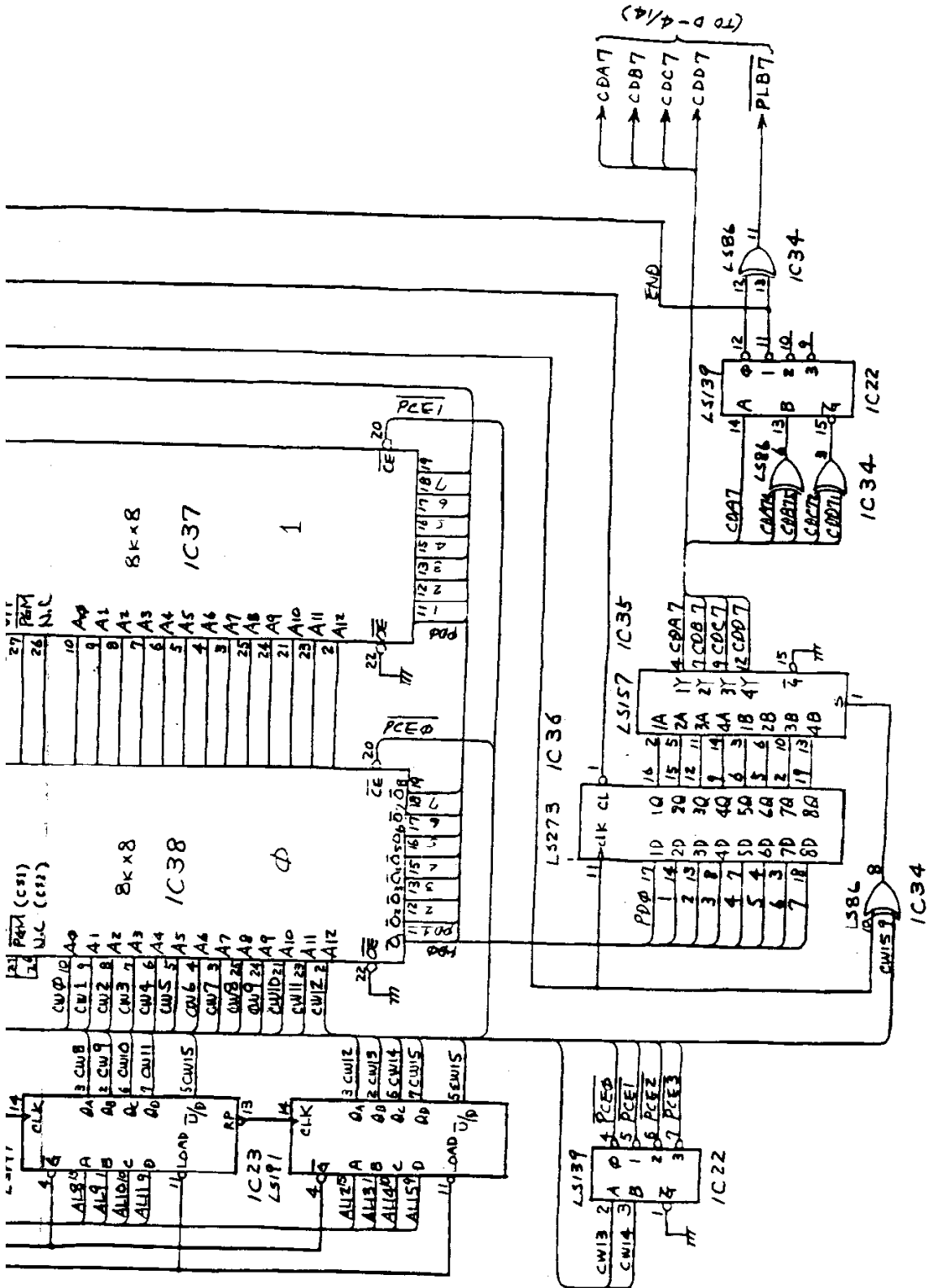

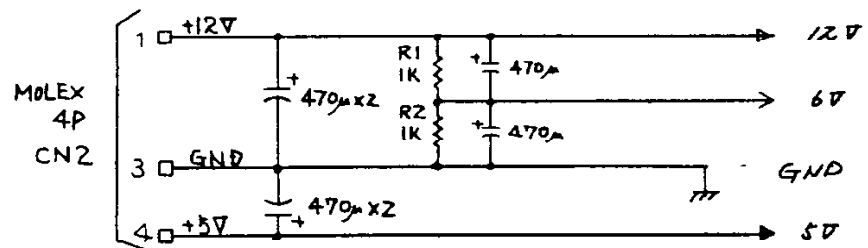
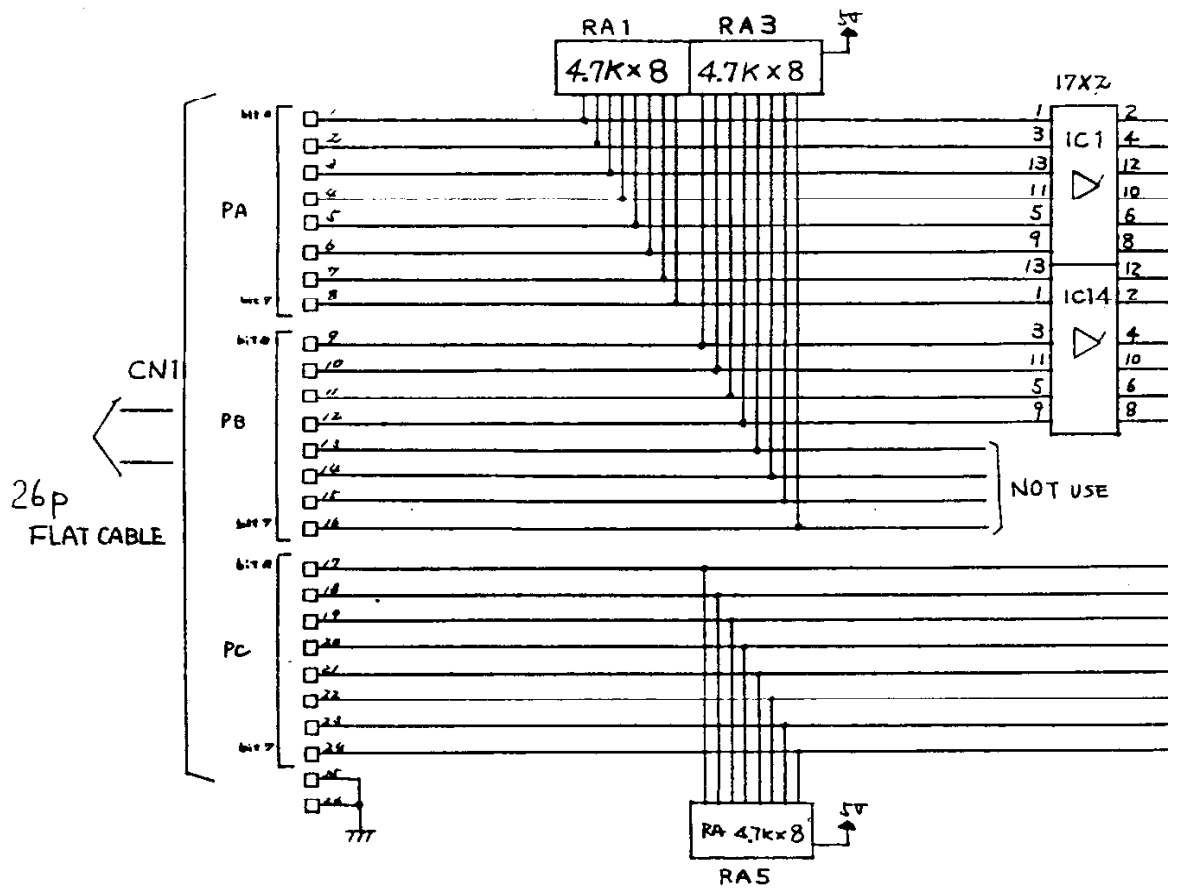

LOGIC DIAGRAM SOUND BOARD D-1/5

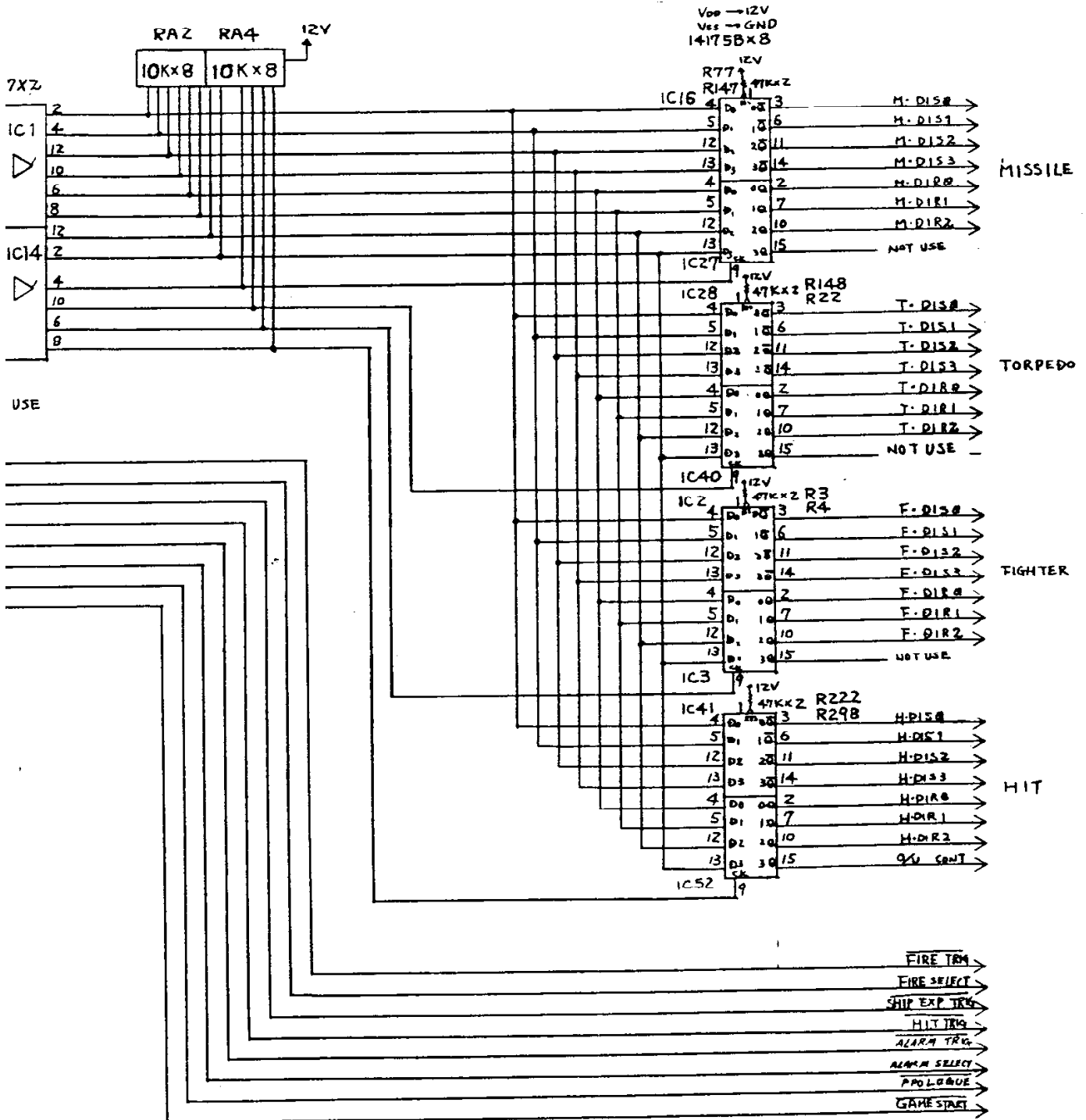

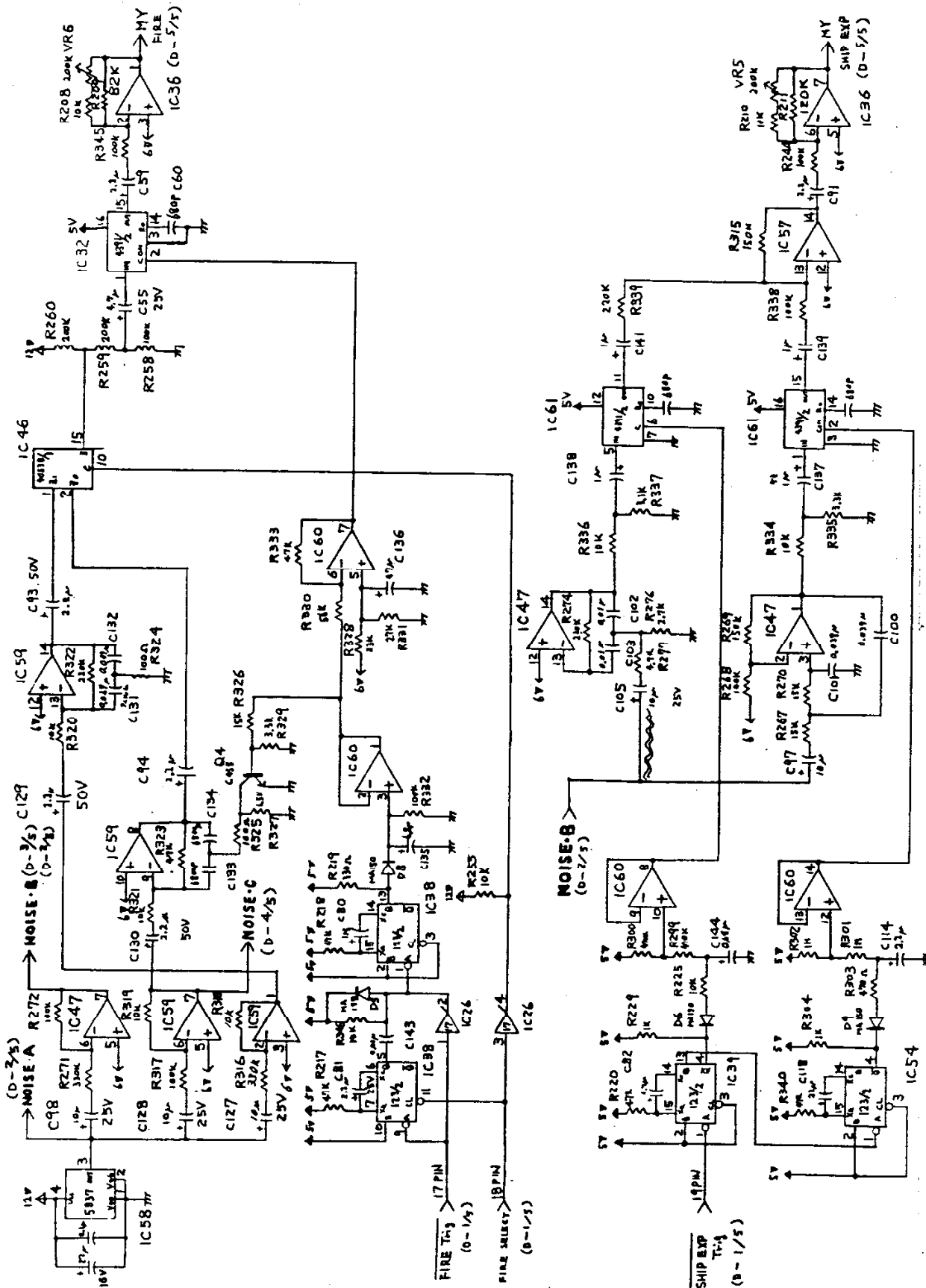

LOGIC DIAGRAM SOUND BOARD D-2/5

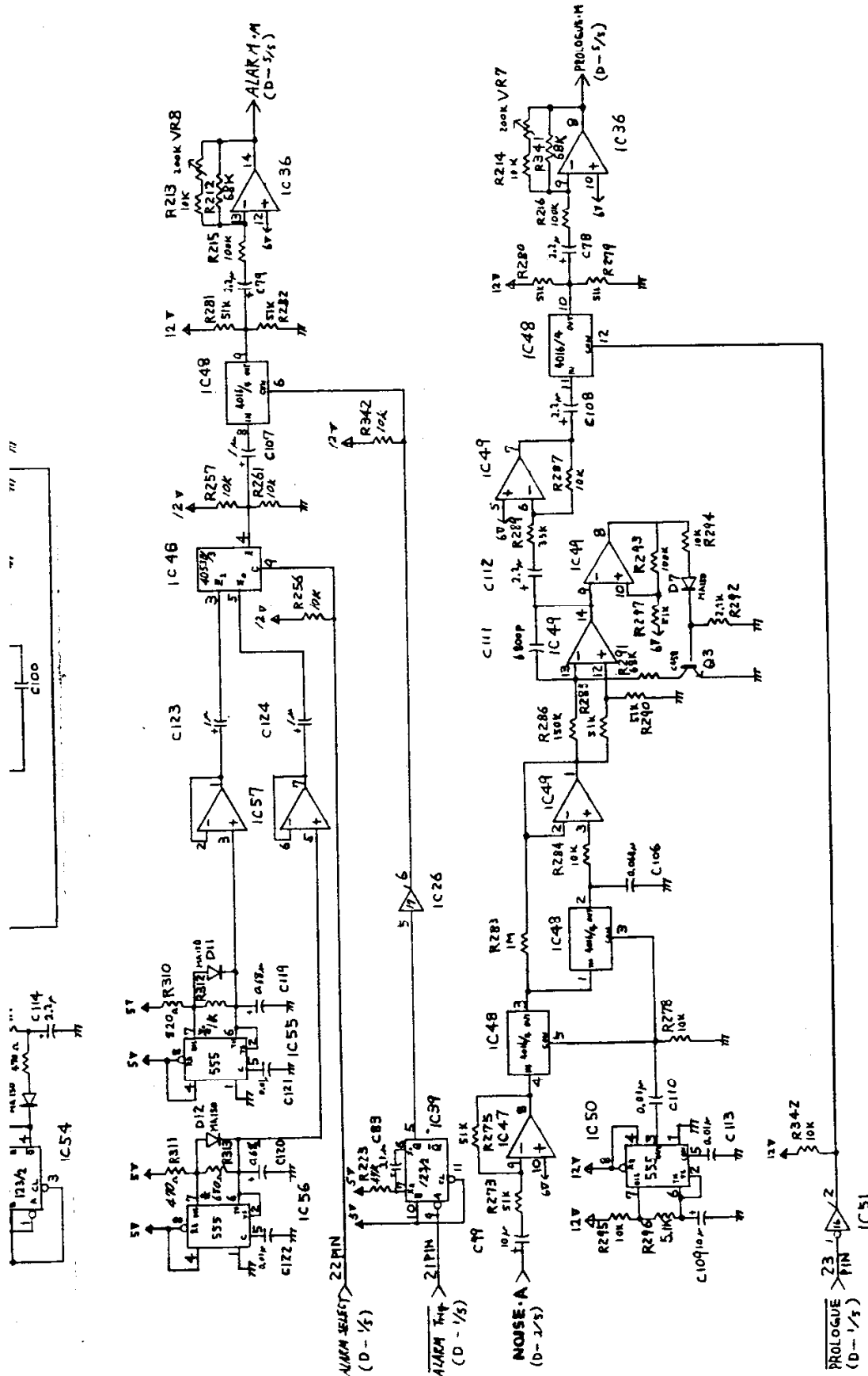

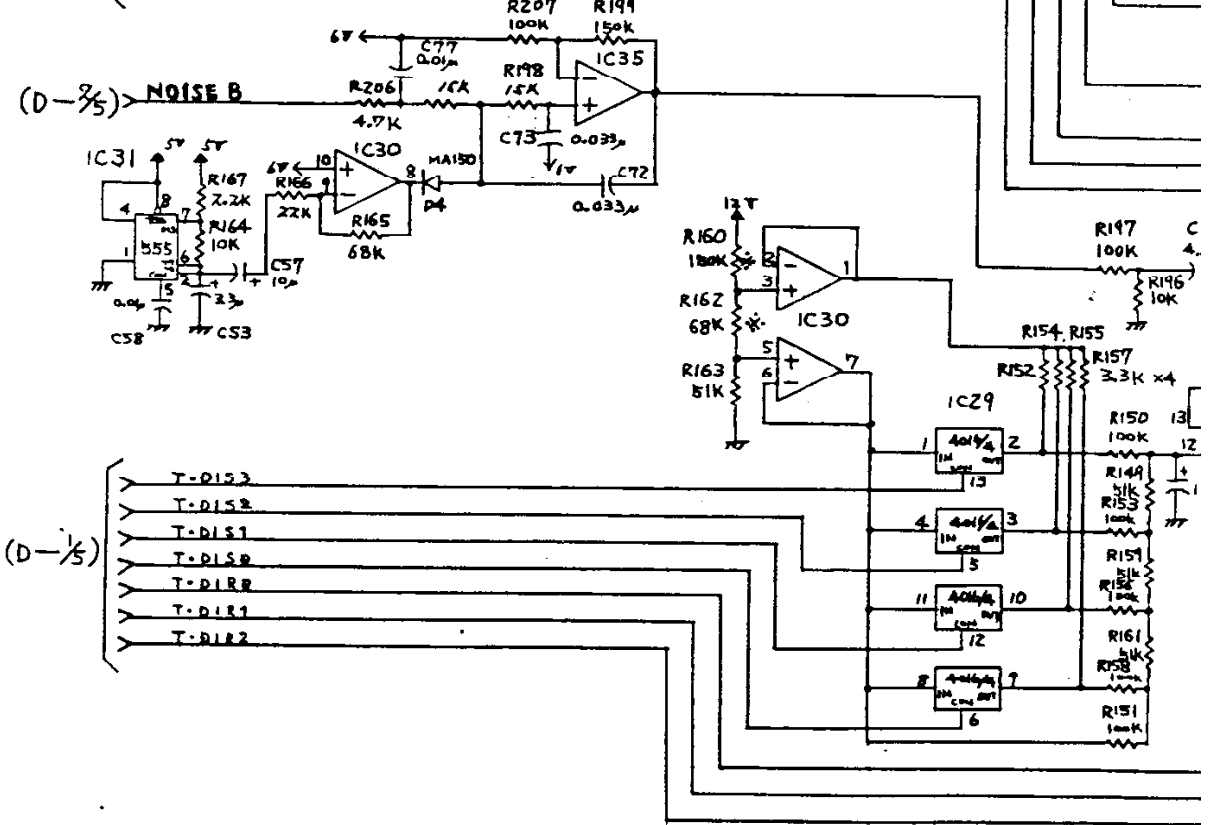
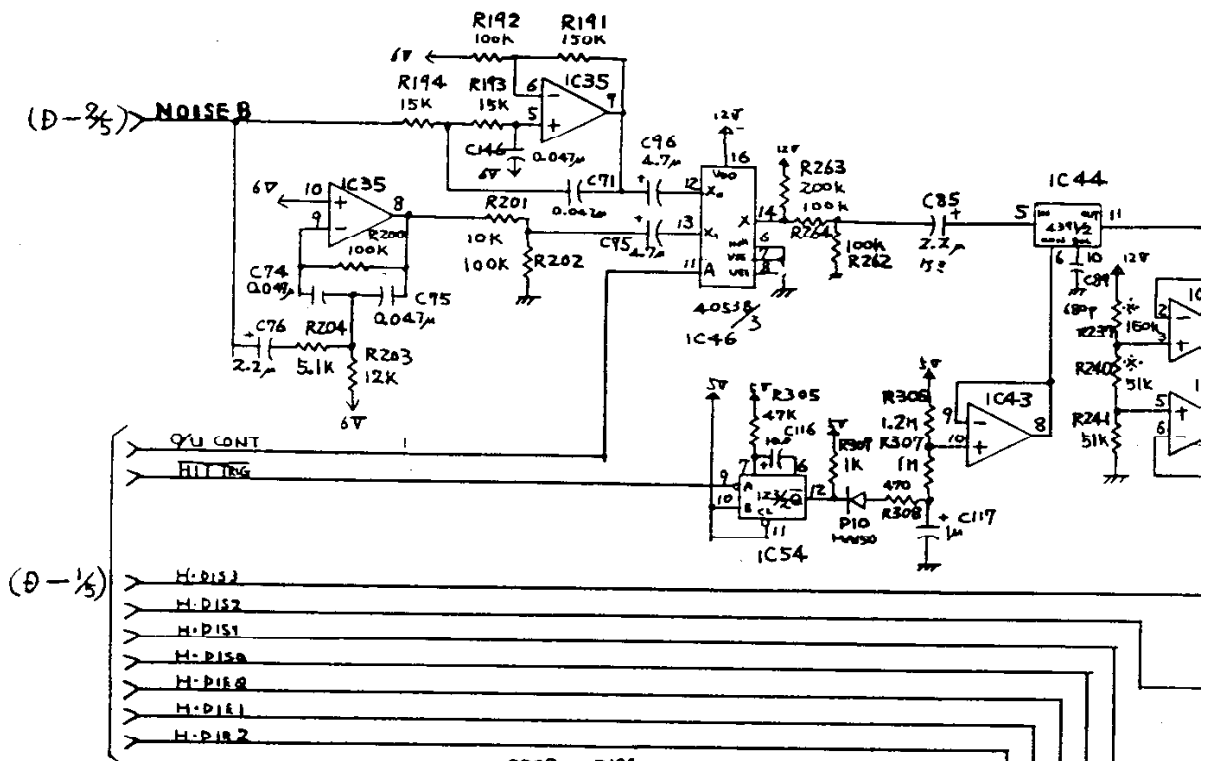

LOGIC DIAGRAM SOUND BOARD D-3/5

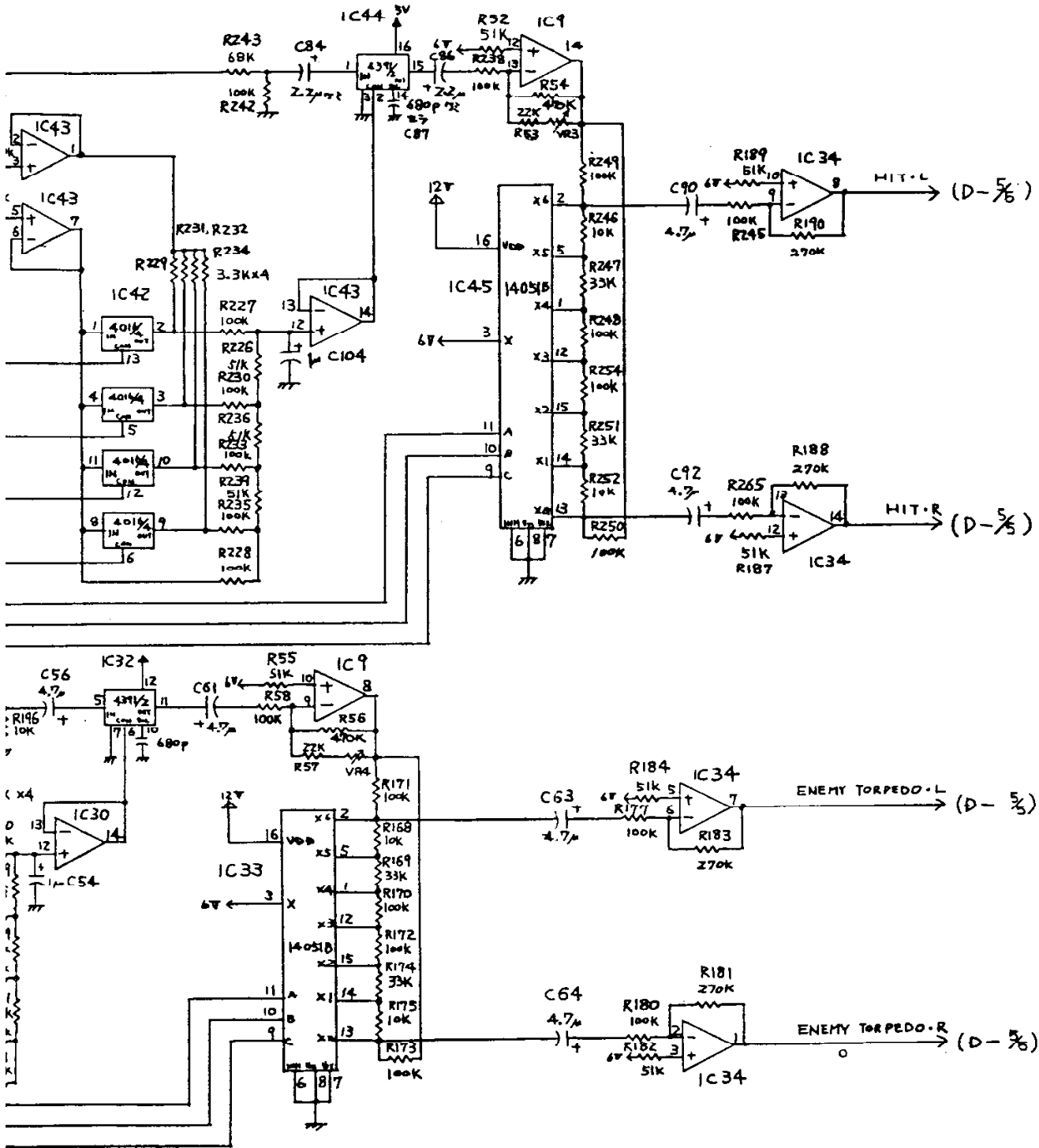

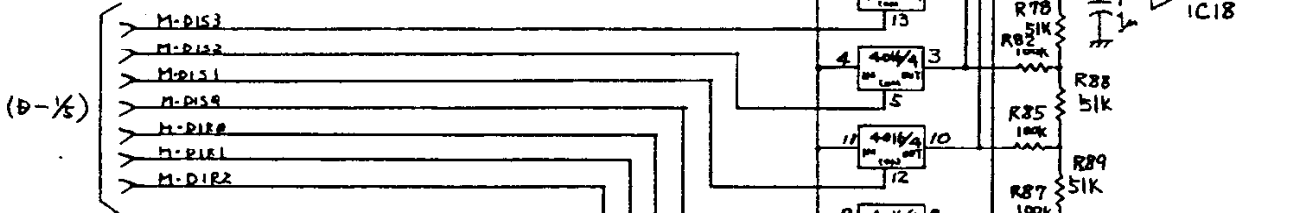
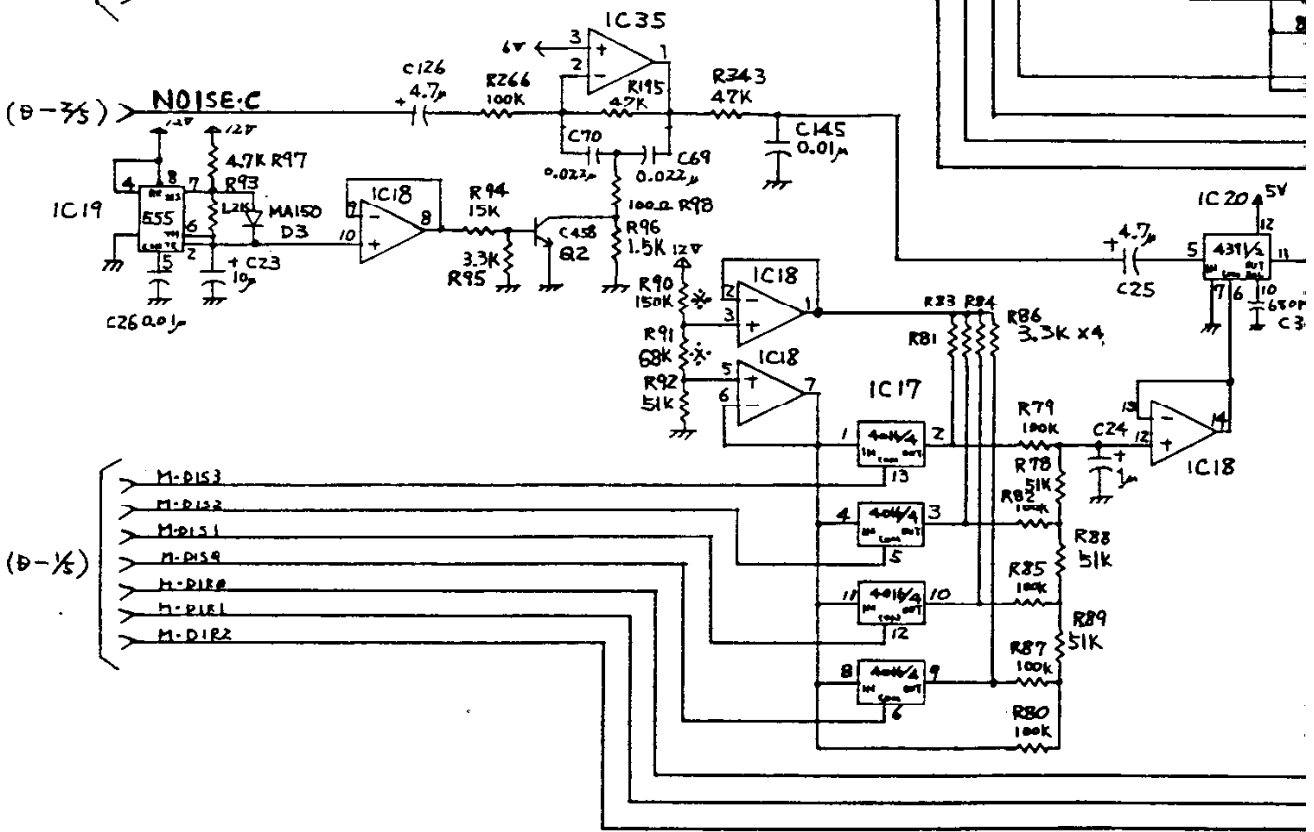
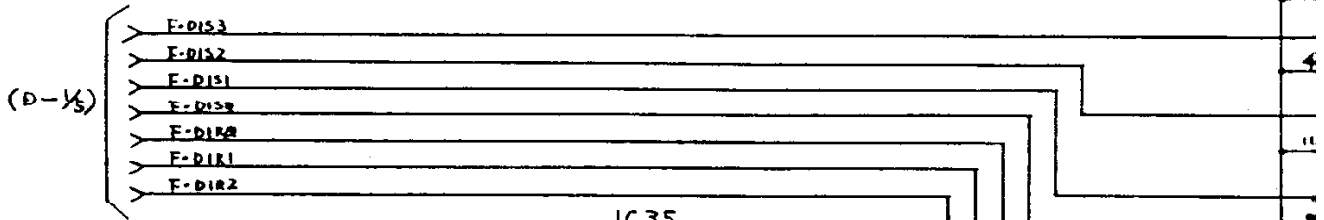
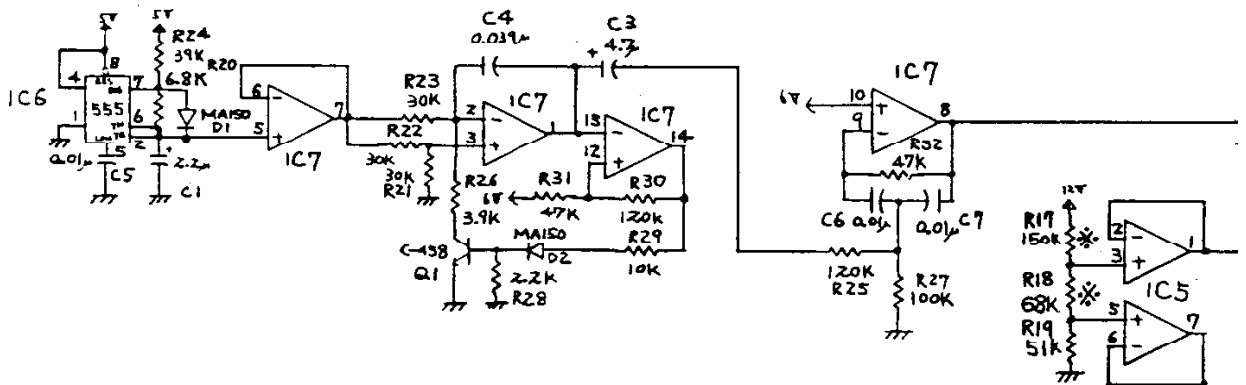

LOGIC DIAGRAM SOUND BOARD D-4/5

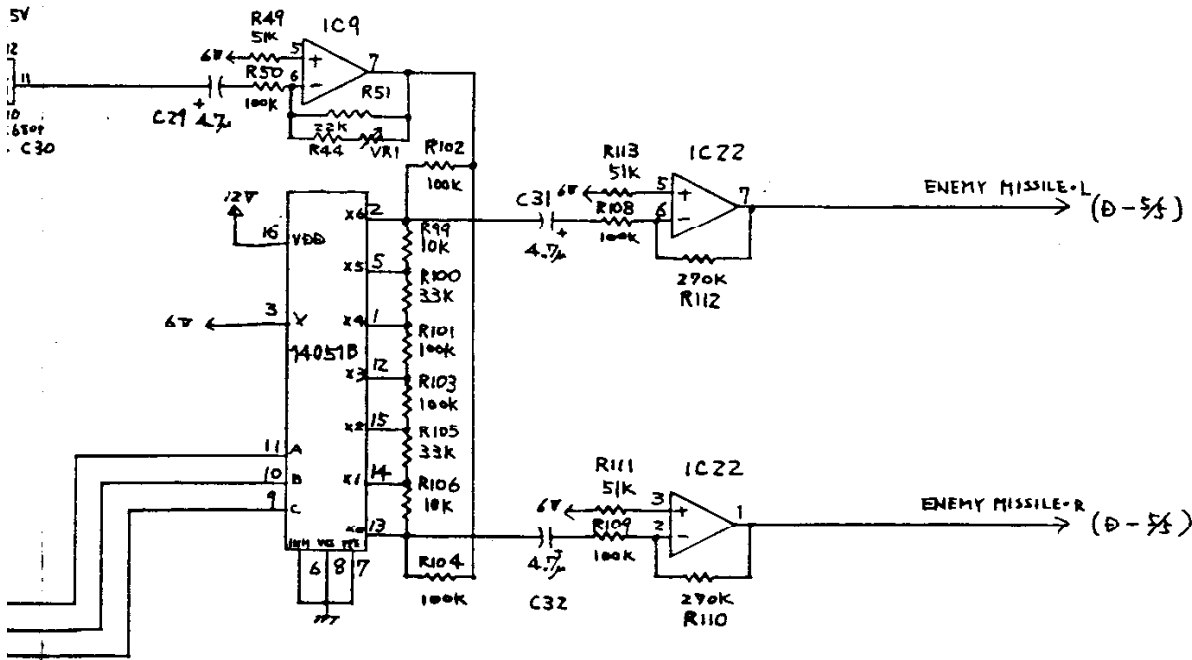
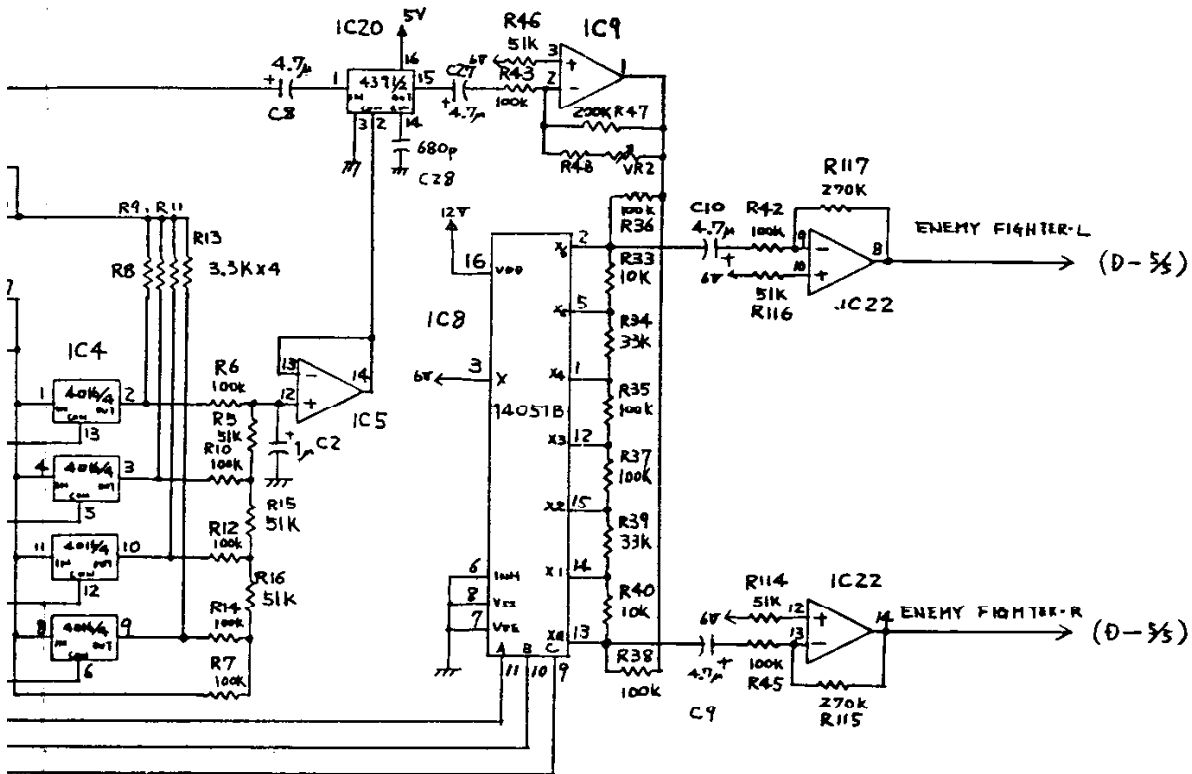

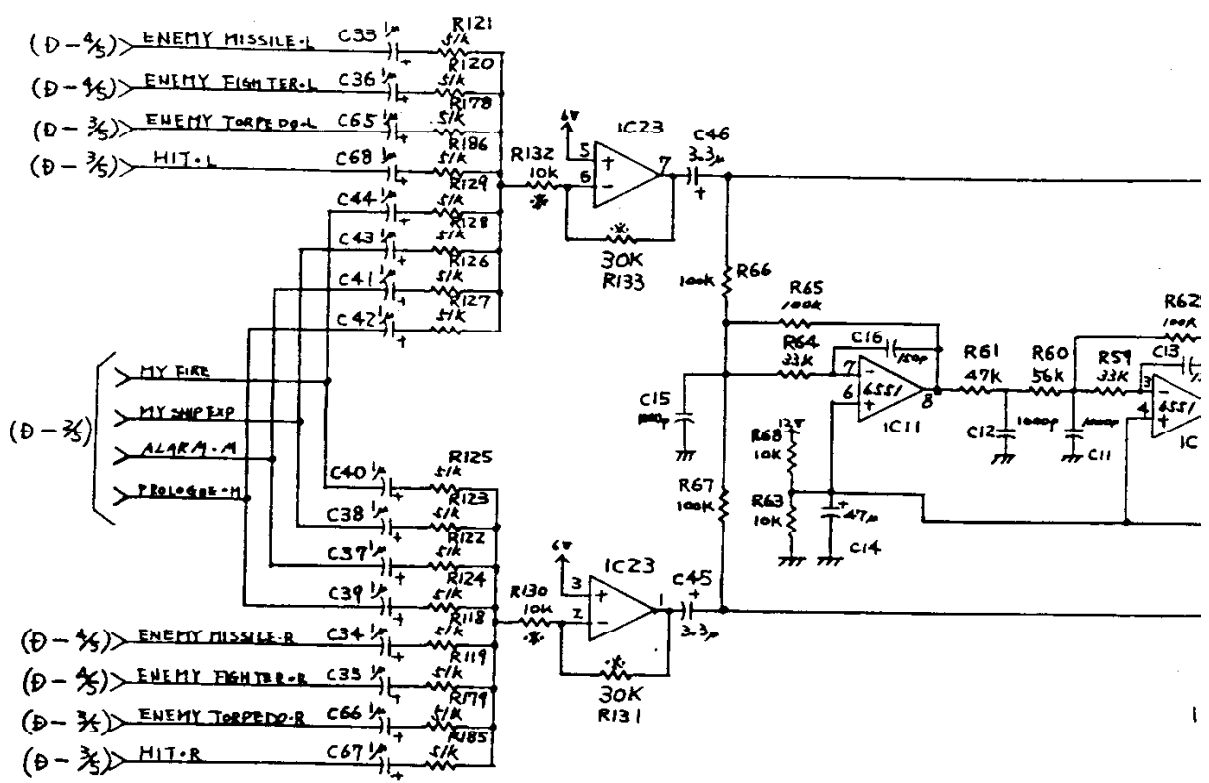

(D-15) GAME START
24 PIN

LOGIC DIAGRAM SOUND BOARD D-5/5

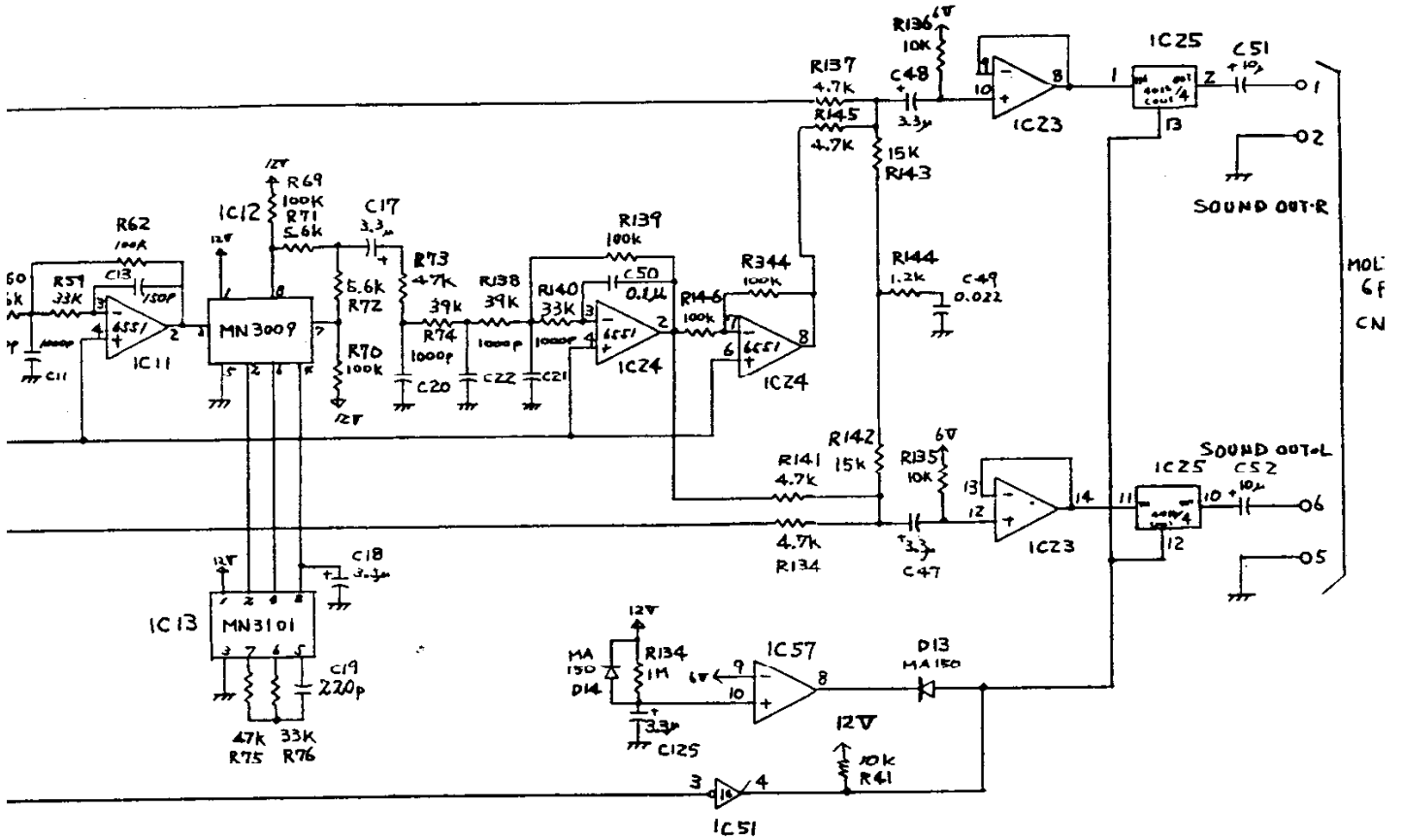

SEGA CUSTOMER SERVICE OFFICES

- Sega Enterprises, Ltd.,
P.O. Box 63,
Tokyo Airport Post Office,
Tokyo 149, Japan,
Tel : 03-742-3171 Tlx : J22357
Cable : SEGASTAR

- Gremlin Industries, Inc.,
16250 Technology Drive,
San Diego, California 92127,
U.S.A.
Technical Assistance (800) 854-1938
Parts Assistance (800) 854-1900
California-Only Technical (800) 722-8576
California-Only Parts (800) 722-8575
Tlx : 9103351621

- Sega Enterprises, Inc.,
2029 Century Park East,
Los Angeles, California 90067
Tel : (213)557-1700
Tlx : 688433 SEGASTAR LSA

- Sega Europe Limited,
15 Old Bond Street,
Mayfair, London W1X 3DB
England
Tel : 01-409 1286
Tlx : 25512 SEGAUK G

SEGA ENTERPRISES, LTD.
No. 2-12 Haneda 1-Chome
Ohta-ku, Tokyo, Japan 144
(03)742-3171

PRINTED IN JAPAN

2ND820805K