

# STAR GUARDS U.R.

## 3 PLAYER

*Bally*

MIDWAY MFG. CO.

10601 W. Belmont Avenue  
Franklin Park, Illinois 60131  
U.S.A.



Phone: (312) 451-9200 Cable Address: MIDCO Telex No.: 72-1596

# STAR GUARDS U.R. - 3 PLAYER

## TABLE OF CONTENTS

<b>SECTION 1 - SYSTEM INFORMATION</b>	<b>PAGE</b>
Game Description .....	1-1
General Instructions: Installation, Servicing, & Self-Test .....	1-3
Option Switch Settings .....	1-5
P.C. Board Reference Drawing .....	1-8
Trouble Shooting Procedure .....	1-9
 <b>SECTION 2 - ILLUSTRATED PARTS BREAKDOWN</b>	
Star Guards Front View: Picture .....	2-2
Star Guards Front View: Parts List .....	2-3
Star Guards Rear Access: Picture .....	2-5
Star Guards Rear Access: Parts List .....	2-7
Header Fluorescent Light Assy.: Picture & Parts List .....	2-9
Joystick Assembly: Illustrated Parts .....	2-10
Coin Door (w/Cable) Front View: Picture .....	2-11
Coin Door (w/Cable) Rear View: Picture .....	2-12
Coin Door (w/Cable): Parts List .....	2-13
Power Chassis: Picture .....	2-15
Power Chassis: Parts List .....	2-16
 <b>SECTION 3 - COMPONENT LAYOUTS, SCHEMATICS &amp; WIRING DIAGRAM</b>	
Monitor Oscilloscope Waveform Patterns & Troubleshooting Chart .....	3-2
Monitor Schematic .....	3-3
Monitor Theory of Operation .....	3-4
Monitor Parts List .....	3-5
Mono Board - Component Layout .....	3-6
Mono Board - Parts List .....	3-7
Mono Board - Schematic .....	3-10
Sounds Good P.C.B. - Component Layout .....	3-23
Sounds Good P.C.B. - Parts List .....	3-24
Sounds Good - Schematic .....	3-25
Dual Power Amp P.C.B. - Component Layout & Parts List .....	3-28
Dual Power Amp P.C.B. - Schematic .....	3-29
Switching Power Supply P.C.B. - Schematic .....	3-30
Uni-Power Supply Chassis Assy. - Schematic .....	3-31
F.C.C. Filter Bd. - Component Layout & Parts List .....	3-32
F.C.C. Filter Bd. - Schematic .....	3-33
Cabinet Wiring Diagram .....	3-34
8 to 4 Multiplexer Bd. - Component Layout, Parts List & Schematic .....	3-36
Eprom List .....	Inside Back Cover

## GENERAL INSTRUCTIONS

### FOR

## STAR GUARDS - 3 PLAYER - U. R.

### INSTALLATION

1. Remove keys from the taped coin return slot and unlock to open the coin box door.
2. Remove four (4) "CABINET LEVELING LEGS" from inside the coin box.
3. Tip the cabinet to the side and remove the shipping cleats from its bottom.
  - Locate the threaded holes - one in each corner - and install the "CABINET LEVELING LEGS" in them.
  - Level the cabinet.
  - When finished, the cabinet should be stable in the upright position.
4. ◦ Unlock and remove the rear access door to gain access to the 3-pronged line cord. Reinstall the rear access door.
5. Connect the 3-pronged line cord to a 3-slot A.C. wall outlet to insure proper grounding.
6. The power ON/OFF switch is located on top to the right rear of the cabinet as you face the cabinet.

### TO SERVICE THE CONTROL PANEL

- Turn power to the game off.
- The control panel is held in place by two (2) latch clamps which provide constant pressure on the strikes.
- They can be reached through the coin door.
- To release the clamps, lift up and toward the center of the control panel.
- Once they are released, unhook them from their strikes.
- Swing out the control panel on it's hinge for servicing.
- To resecure the control panel, reverse this procedure.

**NOTE:** To remove the control panel for bench-servicing only:

- With the control panel in it's open position, disconnect it from it's cabling.
- Remove the screws which secure the continuous hinge to the cabinet.
- The control panel is now loose and may be bench serviced.
- To reinstall the control panel, reverse this procedure.

### REMOVAL OF THE VIEWING GLASS

- Turn power to the game off and swing open the hinged control panel. This frees the viewing glass so it can be removed.

- By putting your fingers in the slot in the middle of the main-display-glass support, the viewing glass can be removed as follows:
  - 1) Lift the glass up.
  - 2) Swing the bottom edge of the glass out slightly forward.
  - 3) Drop the glass down so that its' top edge is slightly below the bottom edge of the speaker grille.
  - 4) Now, holding the glass by its' top edge and bottom edge, lift up and out. To reinstall the viewing glass, reverse this procedure.

#### REMOVAL OF THE HEADER (ATTRACT) GLASS

- Turn the power to the game off.
- The glass is held in place by the speaker grille at the bottom and a retaining bracket at the top.
- The retaining bracket is secured to the cabinet top by five tamper-resistant screws. Remove these screws by using a special wrench provided in the Hardware and Bag Assembly.
- Remove the retaining bracket and slide the header glass up. This exposes the fluorescent light assembly.
- The fluorescent light tube may be replaced at this time.
  - \* **WARNING: If you drop a fluorescent tube and it breaks, IT WILL IMplode!**
  - Use care in handling.**
- To reinstall the header glass, reverse this procedure.

#### REMOVAL OF THE FLUORESCENT LIGHT ASSEMBLY

- Be sure the power to the game has been turned off.
- Disconnect it from it's power cable.
- Remove the fluorescent light assembly's three mounting screws and then remove the assembly from the cabinet.
- To reinstall the fluorescent light assembly, reverse this procedure.

#### REMOVAL OF THE SPEAKER(S)

- Be sure the power to the game has been turned off.
- Remove the header glass and disconnect cabling from the speaker(s).
  - NOTE:** To remove one or both speakers, it is NOT required to remove the speaker grille.
- The grille is held to the cabinet with tamper-resistant screws. Each speaker is secured to the wooden speaker panel by two carriage bolts and two nuts. Remove the speaker(s) by removing the nuts and sliding the bolts out of the grille.
- To reinstall the speaker(s), reverse this procedure.

#### VOLUME CONTROL POT / OPTION SWITCH LOCATIONS

The volume control pot is located, along with the credit switch and the self-test switch, just inside the cabinet on the right side of the coin door frame. The option switch is located as shown in the attached p.c. board reference drawing. For adjustment, it can be reached through the game's rear access door.

To make the sounds louder, turn the volume pot clockwise as you face it.

To make the sounds less loud, turn the volume pot counterclockwise as you face it.

## SELF-TEST MODE

The Self-Test mode is a special mode for checking the game switches and computer functions. It is the most complete way of checking for proper game operation and is quite easy to use.

The Self-Test mode may be entered at any time and from any mode of operation. Simply locate the black slide switch inside the coin door and slide it to the Self-Test position. With this switch in the Self-Test position, activate the slam switch located on the Coin Door. The game will enter the Self-Test mode immediately and display the following test menu....

1. INPUT TEST
2. OUTPUT TEST
3. DIPSWITCH OPTIONS
4. SELF-DIAGNOSTICS
5. GRID TEST

TO MOVE CURSOR UP, MOVE ANY JOYSTICK UP.  
TO MOVE CURSOR DOWN, MOVE ANY JOYSTICK DOWN.  
TO EXECUTE TEST, PRESS ANY START BUTTON.

1. INPUT TEST: This test is designed to confirm the operation of player input switches and device switches in the game. When you enter the test, the screen displays the following:

COIN CHUTE 1 .....	OPEN	PLAYER 2 BUTTON .....	OPEN
COIN CHUTE 2 .....	OPEN	LEFT JOYSTICK 2 .....	1111
COIN CHUTE 3 .....	OPEN	RIGHT JOYSTICK 2 .....	1111
CREDIT BUTTON .....	OPEN		
PLAYER 1 BUTTON .....	OPEN	PLAYER 3 BUTTON .....	OPEN
LEFT JOYSTICK 1 .....	1111 *	LEFT JOYSTICK 3 .....	1111 *
RIGHT JOYSTICK 1 .....	1111 *	RIGHT JOYSTICK 3 .....	1111 *

\* All joystick switches are open: 1 = Open Switch & 0 = Closed Switch.

When you activate any one of the above switches, its' respective message "OPEN" changes to "CLOSED" except for LEFT JOYSTICK 1 (2 and 3) and RIGHT JOYSTICK 1 (2 and 3). For any one of these six:

<u>JOYSTICK POSITION</u>	<u>SWITCH DISPLAY</u>	<u>JOYSTICK POSITION</u>	<u>SWITCH DISPLAY</u>
UP	1110	UPPER LEFT DIAGONAL	1010
DOWN	1101	UPPER RIGHT DIAGONAL	0110
LEFT	1011	LOWER LEFT DIAGONAL	1001
RIGHT	0111	LOWER RIGHT DIAGONAL	0101

To exit this test, activate the coin door slam switch.

2. OUTPUT TEST: This test is designed to confirm the operation of all 3 players' Start button lights. These lights will flash in sequence with the following messages displayed on the screen:

START BUTTON 1 LIGHT ON  
START BUTTON 1 LIGHT OFF

START BUTTON 2 LIGHT ON  
START BUTTON 2 LIGHT OFF

START BUTTON 3 LIGHT ON  
START BUTTON 3 LIGHT OFF

## SELF-TEST MODE, Cont'd.

This cycle continues unless:

- A. You press any one of the Start buttons to hold a light ON.
  - B. You exit the test by activating the coin door slam switch.
3. **DIP SWITCH OPTIONS:** All game options such as "energy units/coin" and "difficulty levels" are adjusted through the use of dip-switches located on the Monoboard. When this test is selected, a full display of the current dip-switch settings will appear on the screen (see "Option Switch Settings" on page 1-7). To exit this test, activate the coin door slam switch.
  4. **SELF-DIAGNOSTIC TEST:** This test is designed to effectively locate and identify any malfunction of the on-board computer. When selected, the game enters this mode immediately and begins scanning the memory stored in rom and ram. If the test is successful, at the end of the scan "ALL TEST OK" is displayed on the screen. If a defective component is found during the scan, that component and its' location will be displayed on the screen. The entire test is performed approximately in 15 seconds. To exit the test, activate the coin door slam switch.
  5. **GRID DISPLAY:** This test is designed to display a crosshatch pattern used in adjusting the color monitor. This pattern may be used to adjust convergence, color balance, vertical linearity, and vertical/horizontal size. To exit this test, activate the coin door slam switch.

## POWER-UP TEST MODE

This test sequence is designed to effectively locate and identify any malfunction of the Sounds Good p.c. board. Test results are indicated by an L.E.D. located on the sound board.

On power-up under normal operation, the sound board runs through its' self-diagnostic checks flashing its' L.E.D. to announce every successful test. At the end of the test run, the attract mode begins.

If one of the tests fails however, the L.E.D. will not flash for the failed test nor for any remaining tests in the sequential run. At this point, "SOUND BOARD INTERFACE ERROR" appears on the screen.

The following is the Self-Test routine for the Sounds Good Board:

- 1st FLASH - Determines if the ROM (U7) is good.
- 2nd FLASH - Determines if the ROM (U8) is good.
- 3rd FLASH - Determines if the ROM (U17) is good.
- 4th FLASH - Determines if the ROM (U18) is good.
- 5th FLASH - Checks to see if the RAM (U6, U16) is good.
- 6th FLASH - Checks the PIA (6821) (U9).

**IMPORTANT NOTE:** There is **NO** battery back up provided for this game. All logic & memory functions will be retained thru dip switch settings.

STAR GUARDS U.R.

OPTION SWITCH SETTINGS

//////////////////// SWITCH NO. 2 - AT A13 - LOCATED ON MONOBOARD //////////////////////

	<u>SW#1</u>	<u>SW#2</u>	<u>SW#3</u>	<u>SW#4</u>	<u>SW#5</u>	<u>SW#6</u>	<u>SW#7</u>	<u>SW#8</u>	<u>SW#9</u>	<u>SW#10</u>
	NOT USED	NOT USED			NOT USED				NOT USED	
<u>ENERGY UNITS/COIN</u>										
8 ENERGY UNITS/COIN			ON	OFF						
10 ENERGY UNITS/COIN			OFF	OFF						
12 ENERGY UNITS/COIN			OFF	ON						
14 ENERGY UNITS/COIN			ON	ON						
<u>ATTRACT SEQUENCE SOUNDS:</u>										
SOUNDS							OFF			
NO SOUNDS							ON			
<u>DIFFICULTY LEVEL:</u>										
EASY							ON	OFF		
MEDIUM							OFF	OFF		
HARDER							OFF	ON		
HARDEST							ON	ON		
<u>VIDEO FREEZE MODE:</u>										
NORMAL VIDEO										OFF
FREEZE VIDEO										ON

FACTORY SETTING - ALL LOGIC SWITCHES SET IN THE "OFF" POSITION | PART NO. M051-00E89-A007

P.C. BOARD REFERENCE DRAWING

FOR MONOBOARD SYSTEM

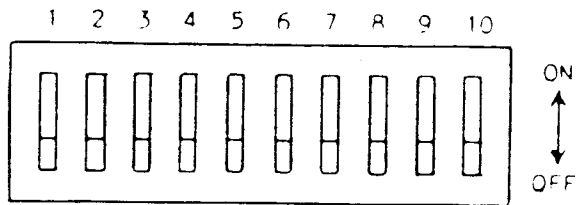
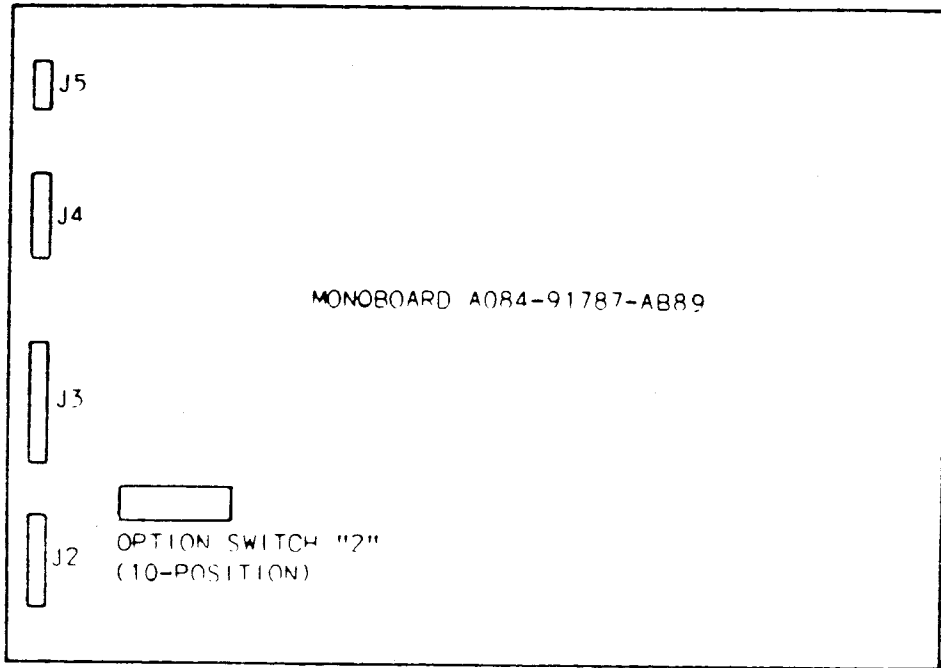



## INTRODUCTION

This manual offers generalized troubleshooting procedures for common types of malfunctions which can be applied to most video games. We will not attempt to give you specific instructions for troubleshooting particular games because this would involve hundreds of pages of more repetitive instructions, differing only in the specific details of each game.

The most common problems occur in harness components such as the coin acceptor, player controls, interconnecting wiring, etc. These areas are covered in moderate detail.

The TV Monitor and Game Logic Printed Circuit Boards (PCB's) provide their fair share of problems too, but not to the extent of the harness and its component parts.

As you already know, the Game Logic PC Boards are complex devices. Each contains a great number of different interrelated circuits. The major changes which give each game its own particular individuality are accomplished in the EPROMS and other Integrated Circuit devices that are installed on each of these PC Boards.

## GENERAL TROUBLE SHOOTING SUGGESTIONS

The first step in troubleshooting is to correctly identify the malfunctions symptoms. This includes not only the circuits or features malfunctioning, but also those still operational. A carefully trained eye will pick up other clues to what's wrong as well. For instance, a game in which the computer functions fail completely just after money was collected may have a quarter shorting the PCB traces. Often an experienced troubleshooter will be able to spot the cause of a problem even before opening the cabinet.

After all the clues are carefully considered, the possible malfunctioning areas can be narrowed down to one or two good suspects. Those areas can be examined by a process of elimination until the cause of the malfunction is discovered.

## HARNESS COMPONENT TROUBLESHOOTING

Typical problems falling in this category are coin and credit problems, power problems, and failure of individual features.

**NO GAME CREDIT** - - For example, a prospective game player inserts a quarter or token and is not awarded a game. The first thing to check is whether or not the quarter or token is returned. If it was returned, the malfunction most certainly lies in the coin acceptor itself. First, use a set of test coins (both old and new) to ascertain that the player's coin is not undersize or underweight. If your test coins are also returned, coin acceptor servicing is indicated. Generally, the cause of this particular problem is a maladjusted magnet gate. Normally, this will mean slightly closing the magnet gate by turning the adjusting screw out a bit.

If the quarter or token is not returned and there is no game credit, the cause of the malfunction may be in one of several areas. First, try operating the coin return button; if the coin is returned, the problem is most likely in the magnet gate. Enlarge the gap according to the coin acceptor manufacturers service procedures. If this does not cure the problem, remove the coin acceptor, clean it, and perform the manufacturers suggested major adjustment procedure.

If the trapped coin is not returned when the wiper lever is actuated, you may have an acceptor jammed by a slug, gummed up with beer, a jammed coin chute, or mechanical failure of the acceptor mechanism. In this case, first check for the slug that will generally be trapped against the magnet. If a slug is found, simply remove it and test the acceptor. If the chute is blocked, remove the acceptor and remove the jammed coins. If there is actual failure of the acceptor, remove the unit and repair as indicated by the acceptor manufacturers service procedures.

If the coin is making its way through the acceptor (that is, falling into the coin box), yet there is still no game credit, you either have a mechanical failure of the coin switch or electrical failure of the coin and credit circuits. The first place to begin is by checking the coin switch. Most of these switches are the make/break variety of micro switch. They are checked for continuity between the "NO", "NC", and "C" terminals. When **not** actuated, the "NC" and "C" terminals should be continuous and the "NO" terminal open. When actuated, the "NO" and "C" terminals should be continuous and the "NC" terminal open. If the coin switch checks good, inspect the solder connections to the coin switch terminals to be sure there is good contact at this point. If necessary, use a continuity tester and check from the terminal lug on the switch to the associated PCB trace. This will tell you if there is a continuous line all the way to the credit circuit.

If the coin switch wires do check good, the problem is in one of the game logic boards - - most likely in the coin and credit circuitry.

If you do get a game credit when a coin is deposited, but the game will not start when the one or two player start button is pressed, there may be a problem in the start switch, the interconnecting wiring, or the game logic boards. First, check the switch. If the switch is OK, proceed to check the wiring. Again, make sure you go from the terminal lug on the switch to the PCB trace. This way, you will check the terminal contact as well as the PCB edge connector contact. If the wiring is continuous, proceed to check the PCB credit circuit. If not, check each section of the wiring, until the discontinuity is located. If the wiring is OK, the problem must lie in the games logic boards.

#### TRANSFORMER AND LINE VOLTAGE PROBLEMS

Your game **MUST** have the correct line voltage to operate properly. If the line voltage drops too low, one of the games logic circuits will disable the credit acceptance circuit. The point at which the games logic circuits will fail to function is approximately 105 volts AC.

Low line voltage may have many causes. Line voltage normally fluctuates a certain amount during the day as the total usage varies. Peak usage times occur mainly at dawn and/or dusk. So if your games problem seems to be related to the time of day, this may be a factor. A large load connected to the same line as the game (such as a large air conditioner or other device with an exceptionally large electric motor) may drop the line voltage significantly when starting up. This drop can result in an intermittent credit problem. In addition, poor connections in the location wiring, plug, or line cord may also cause a significant drop in power. Cold solder joints in the games harness, especially in areas like the transformer connections, interlock switch, or fuse block, may also produce the same results, although probably on a more permanent basis.

Sometimes location owners (especially in bars) replace light switches with dimmer rheostats, and the game is sometimes on the same line. Obviously, the voltage available to the game is going to drop dramatically when the dimmer is turned down.

In any case, the way to check for proper line voltage is with your VOM. Set the VOM to the 250 VAC scale and stick the probes into the wall outlet the game was connected to. If it's OK here, check the transformer primary connections. If you do not get 117 VAC, examine the solder joints on the transformer, fuse block, and interlock switch. If you do get 117 VAC, the problem must be either in the transformer, harness connections, or in the PCB power supply.

If you suspect the transformer, check its secondaries with the VOM set to the 50 VAC scale and correlate the readings with the legend on the side of the transformer. The transformer must also be correctly grounded, so check the ground potential as well, especially if there is a hum bar rolling up or down the Monitor screen.

**NO POWER, NO PICTURE** - - If the Monitor screen is completely dark, first look in back of the Monitor to see if the CRT filament is glowing. If it is, try adjusting the brightness control. If no luck here, put your ear near the Monitor and listen for the high-pitched B+ hum produced by the flyback transformer. If you get the hum but no picture, and you have tried adjusting the brightness, major Monitor servicing is indicated.

If the monitor seems completely dead, check the rest of the game to see if it has power. If it doesn't, go directly to the wall outlet and check there. If OK there, check the game fuse(s), interlock switch, and interconnecting wire lengths.

Sometimes it is difficult to tell if a slow-blow fuse has blown. If in doubt, check it using any of the VOM "R" scales.

**HARNESS PROBLEMS** - - Other harness problems include blowing fuses and malfunctioning controls. The repeating blown-fuse problem can sometimes be quite exasperating to solve. Short circuits have the tendency to occur in areas almost impossible to find. First, try inserting a new fuse as old fuses age and sometimes blow without cause. If the new fuse also blows, you definitely have a short.

The best way to approach this problem is by disconnecting devices that may be causing the problem, such as the TV Monitor, the various PCB's one at a time, and the isolation transformer. Disconnect the devices by FIRST turning the game off, disconnecting it from its wall outlet. Remove the blown fuse and connect your VOM across the terminals of the fuse block (this will save blowing a fuse each time you want to check the circuit). Set your VOM to one of its resistance scales. You should be reading a short. If not you probably have a part that only shorts out after it is heated up - we'll cover this in a minute. So, assuming you are reading a short on your VOM, disconnect the components from their cabling one at a time, checking the VOM after each one is disconnected. When the short disappears, you have just disconnected the bad component. If all components are disconnected and the short still remains, the problem is in the harness and only patient exploration will reveal its location. Carefully examine all the wiring, looking for terminals that may be touching, metal objects such as coins shorting the connections, or burned insulation. If necessary, use the VOM to check each suspected wire.

OK, now lets assume that you connected your VOM across the fuse block terminals as stated above and you did not read a short. This most likely means that you have a component somewhere in that game that **ONLY** goes bad **AFTER** it heats up. It checks good when its cold. In this case, turn the game off and disconnect **ALL** of its components. Install a known good fuse in the fuse block. And turn the game on. If the fuse does not blow after a few minutes, you know that it is not anything to do with the wire harness. (In this instance, it shouldn't be, actually. But it never hurts to check.) Next, turn the game off again and reconnect **ONE** component. Turn the game back on and wait a few minutes to see if the fuse blows. If it does not, turn the game off again and reconnect another single component.

Turn the game back on and wait a few minutes to see if the fuse blows. Repeat this procedure until the fuse blows. When it does blow, the last component you connected has the part on it that is going bad after it warms up and is shorting out.

**MALFUNCTIONING CONTROLS** - - The most common problem here is the bad potentiometer (pot). Typically, a bad pot will cause the image on the screen to jump when it reaches a certain point. The only cure for this one is to install a new pot.

If a feature that is operated by a switch (for example, joysticks, foot pedals, control panel buttons) does not operate at all, check the switch with a VOM or continuity tester to verify its operation. If the switch does not check good, replace it. If the switch is OK, you should suspect the input to the switch from the PCB. In this case, get out the harness and logic schematics and check to see what kind of input is supposed to be at this switch. In many cases, the input will be +5 volts DC. If so, use the VOM to check its presence with the game turned on. Normally, the switch is used to pull a +5 volt DC line LOW to GROUND or to pull a LOW line HIGH. If the PCB output is missing, check the wire length from the PCB. If you find the signal at the PCB trace, the wire length or connection is at fault. If there is no signal at the PCB trace, begin exploring the PCB using the logic schematics and game manual.

SECTION 2

ILLUSTRATED PARTS BREAKDOWN

STAR GUARDS U.R. - 3 PLAYER - FRONT VIEW

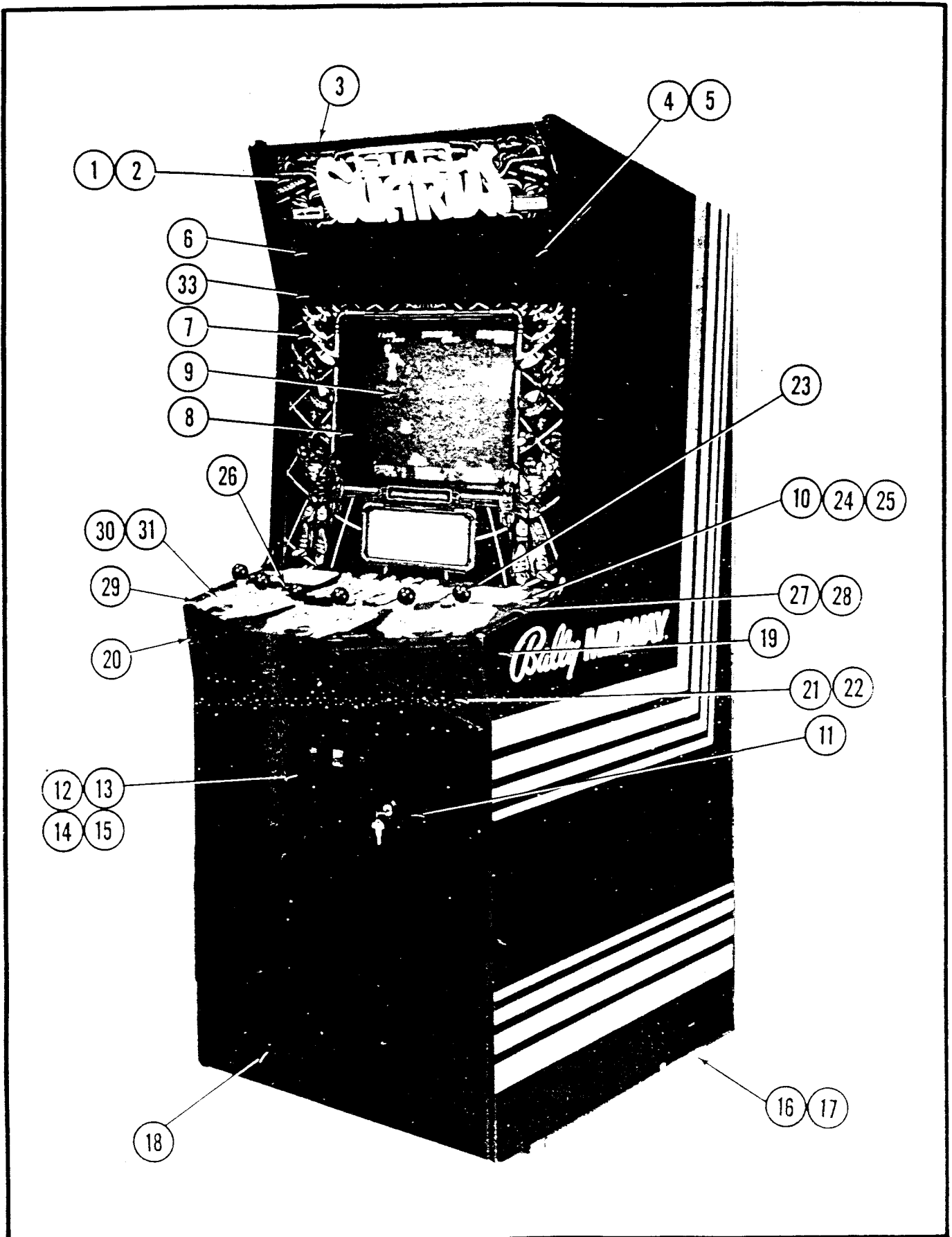

**STAR GUARDS U.R. - 3 PLAYER - FRONT PARTS LIST**  
**ORDER BY PART NUMBER ONLY**

ITEM	PART NO.	DESCRIPTION
1	0E89-00900-00XF	HEADER GLASS: SCREENED
2	A595-00011-0000	HEADER FLUORESCENT LIGHT ASSY. (BEHIND HEADER SEE PG. 2-9)
3	0574-00903-0700	HEADER RETAINING BRKT.
*	0017-00101-0138	#8 X 5/8" TORX TAMPER RESISTANT PAN SCREW (11 REQ'D.)
*	0017-00009-0522	LONG ARM KEY: (FOR ABOVE SCREW) TAMPER RESISTANT
4	0E36-00102-00XF	SPEAKER GRILLE
5	0017-00003-0570	5-1/4" SPEAKER - 4 OHM, 15W (2 REQ'D.) (NOT SHOWN)
6	0017-00042-0127	8-32 X 1-1/2" CARRIAGE BOLT (4 REQ'D.)
7	0017-00042-0314	BEZEL: 19" INJECTION MOLDED
8	0E89-00901-00XF	MAIN VIEWING GLASS
9	0017-00003-0465	WELLS-GARDNER - 19" COLOR DUAL SYNCH HORIZONTAL MTG. MONITOR
10	AE68-00004-0000	CONTROL SHELF ASSY.: (INCLUDES ITEMS 20 THRU 31)
*	0017-00009-0534	BASSICK CLAMP (2 REQ'D.) (NOT SHOWN)
*	.0555-00901-0000	PIN: LOCATING (MOLDED) (8 REQ'D.) (NOT SHOWN)
11	0090-00002-04BK	COIN DOOR FRAME: LARGE BLACK, TRIPLE
12	A982-00014-0021	U.S.A. 25¢ COIN DOOR & CABLE ASSY.
13	0017-00009-0477	CASH BOX: MOLDED (BEHIND COIN DOOR)
14	0950-00115-0000	COVER: COIN BOX (BEHIND COIN DOOR)
15	0950-00901-0000	BASKET: COIN BOX - WIRE (BEHIND COIN DOOR)
16	0017-00102-0048	LEG LEVELERS (4 REQ'D.)
17	0017-00103-0026	NUT 3/8 -16 HEX (FOR LEG LEVELERS) (4 REQ'D.)
18	0935-00906-1100	PLATE: KICK L = 27 - 5/8"
19	0E36-00105-0100	BRKT.: SHELF-SUPPORT: RIGHT (UNDER CONTROL SHELF)
20	0E36-00105-0200	BRKT.: SHELF-SUPPORT: LEFT (UNDER CONTROL SHELF)
*		<b>NOT PART OF ABOVE ASSEMBLY &amp; MUST BE ORDERED SEPARATELY</b>

STAR GUARDS U.R. - 3 PLAYER - FRONT PARTS LIST, CONT'D.

ORDER BY PART NUMBER ONLY

ITEM	PART NO.	DESCRIPTION
21	AE36-00010-00XF	CONTROL - APRON WELD ASSY.
22	AE89-00005-0000	CONTROL SHELF CABLE ASSY. (UNDER CONTROL SHELF)
23	AE36-00021-0000	JOYSTICK - ASSY.: SHAFT & PLATE (6 REQ'D.) (SEE PAGE 2-10) OR
23	0017-00009-0694	JOYSTICK - ASSY.: SHAFT, BALL & PLATE
24	0E89-00100-00XF	PLATE: CONTROL SHELF
25	0E89-00902-00XF	OVERLAY: CONTROL-SHELF
26	0017-00032-0093	SWITCH: SPST PUSHBUTTON W/RED LIGHT (3 REQ'D.)
27	0E36-00106-0000	STRIKE: CONTROL-SHELF (2 REQ'D.) (UNDER CONTROL SHELF)
28	0E89-00501-0000	CONTROL SHELF: WOOD
29	0017-00101-0138	#8 X 5/8" TORX TAMPER RESISTANT PAN SCREW (8 REQ'D.)
30	0017-00101-0620	8-32 X 1/2" CARRIAGE BOLT (24 REQ'D.)
31	0017-00103-0061	NUT: 8-32 HEX W/SEMS (28 REQ'D.)



STAR GUARDS U.R. - 3 PLAYER - REAR ACCESS

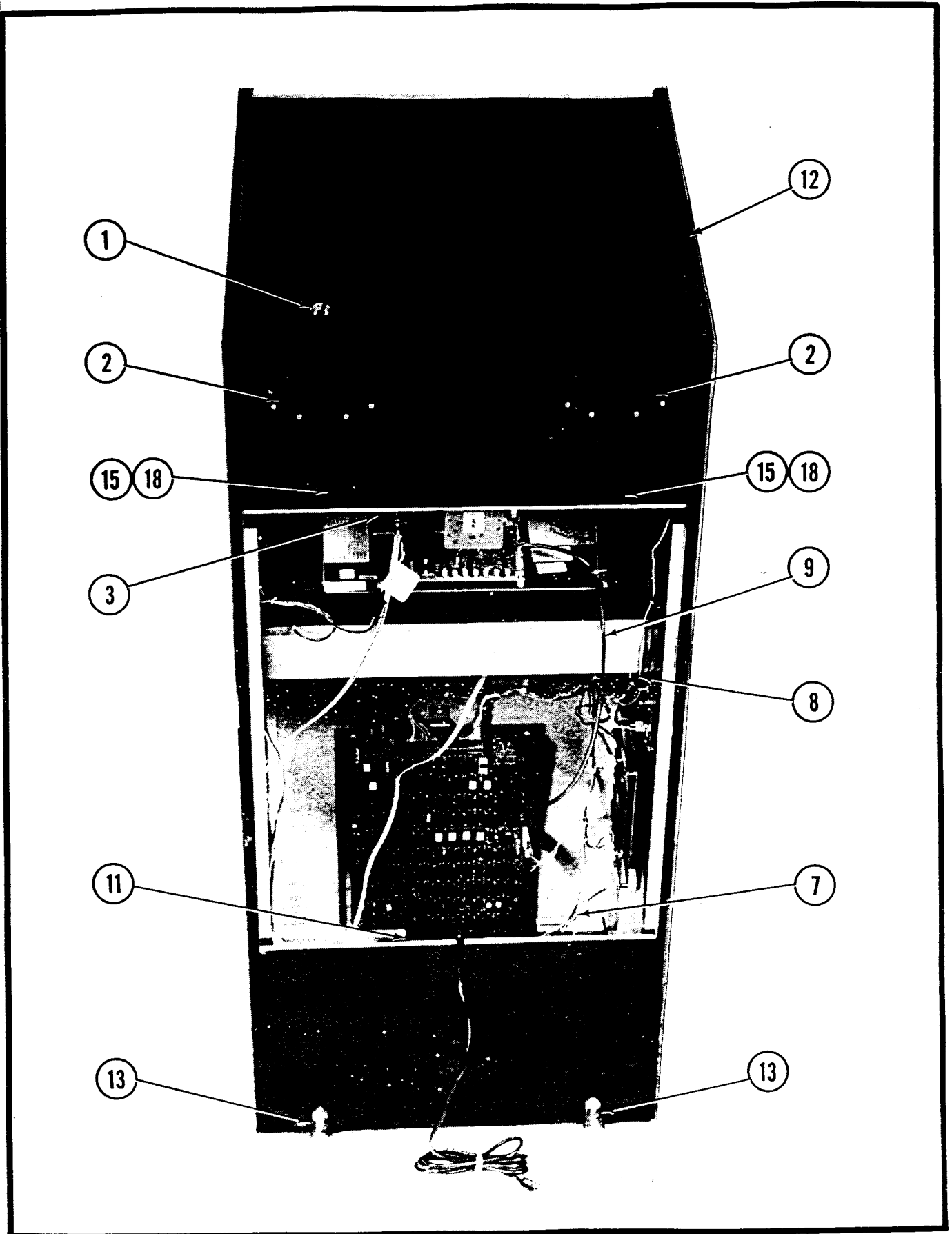

STAR GUARDS U.R. - 3 PLAYER - REAR ACCESS

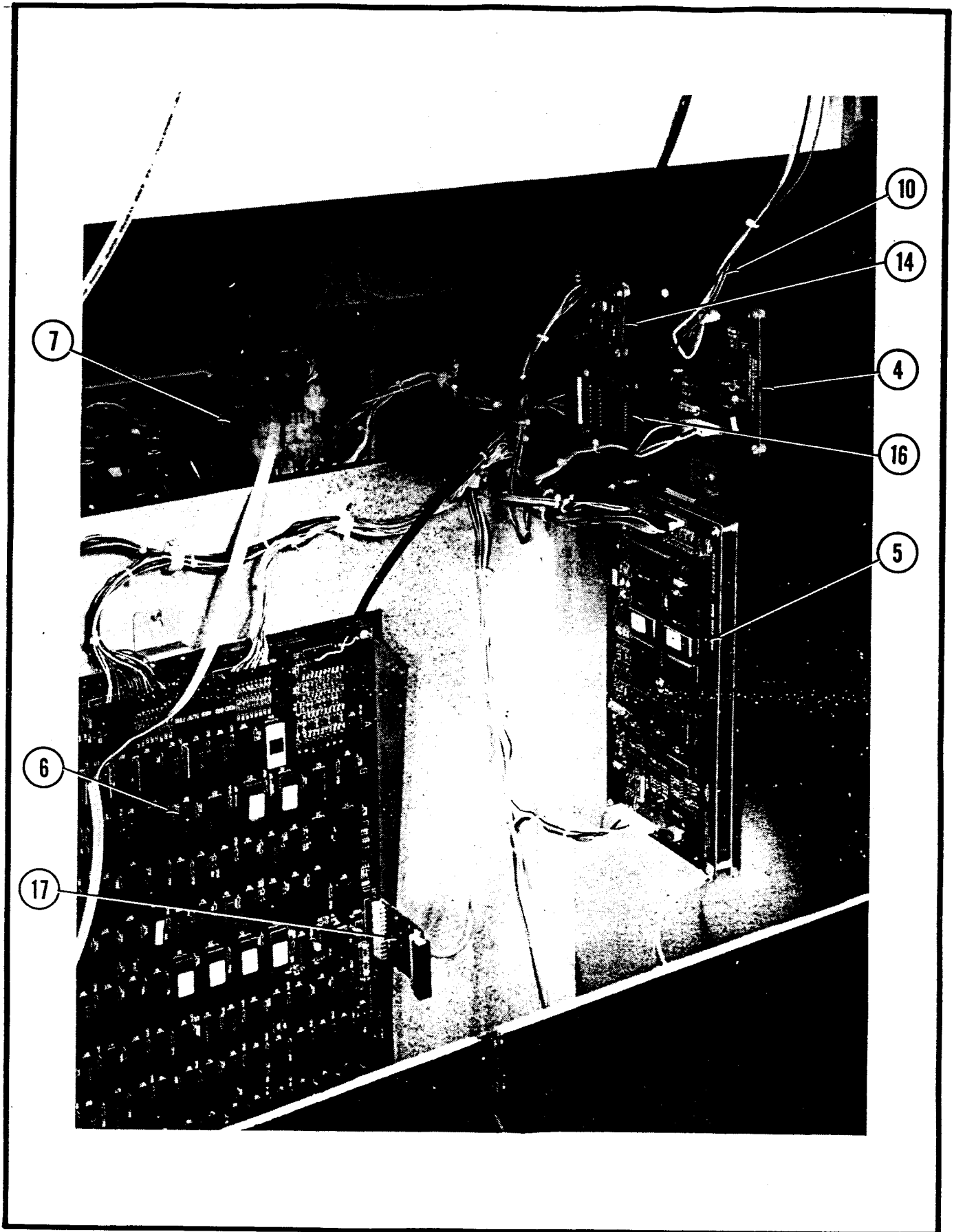

**STAR GUARDS U.R. - 3 PLAYER - REAR ACCESS PARTS LIST**

ORDER BY PART NUMBER ONLY

ITEM	PART NO.	DESCRIPTION
1	A945-00062-0000	ON-OFF SWITCH & PLATE ASSY.
	0017-00032-0105	SWITCH: 2PST 6 AMP
	0017-00104-0111	WASHER .516" I.D., 1.25" O.D., .062" TH. FLAT NYLON (2 REQ'D.)
	0567-00106-0500	PLATE: SWITCH MTG.
2	0894-00916-0100	PLASTIC PULL & VENT (2 REQ'D.)
3	0017-00003-0465	WELLS-GARDNER - 19" COLOR DUAL SYNCH HORIZONTAL MTG. MONITOR
4	B084-90910-F000	DUAL POWER AMP P.C.B. ASSY.
5	AE89-00011-0000	CARDRACK W/SOUNDS P.C.B. ASSY. (SEE PG. 2-5)
	B084-91863-AE89	PROGRAMMED SOUNDS GOOD P.C.B.
	A385-00024-0000	BRACKET, SHIELD & SPACER ASSY.
6	AE89-00012-0000	CARDRACK W/MONOBOARD ASSY. (SEE PG. 2-5)
	B084-91787-AE89	PROGRAMMED MONOBOARD ASSY.
	AE36-00013-0000	SHIELD & SPACER ASSY.: MONOBOARD
7	AE68-00006-0000	MASTER CABLE W/BRKT. ASSY.
	A515-00021-0000	MULTIFUNCTION SWITCH BRKT. ASSY. (INCLUDES FOLLOWING 6 ITEMS)
	0017-00032-0007	SWITCH: SPDT SLIDE 4 AMP
	0515-00107-0000	BRKT: CREDIT: TEST-SWITCH: VOLUME
	0017-00032-0051	BUTTON: SWITCH, RED
	105E-00001-0017	POT.: 0-1K CBN 1/2W
	0017-00103-0075	NUT: 3/8 - 32 HEX
	0017-00104-0104	WASHER: .375" I.D., .562" O.D., .018 TH. INTERNAL TOOTH LOCK
8	AE36-00008-0000	HIGH VOLTAGE CABLE ASSY.
	0017-00003-0500	LINE-CORD: 3-CONDUCTOR 18 AWG.
9	AE36-00002-0000	VIDEO CABLE ASSY.

**STAR GUARDS U.R. - 3 PLAYER - REAR ACCESS PARTS LIST (CONT'D.)**

**ORDER BY PART NUMBER ONLY**

<b>ITEM</b>	<b>PART NO.</b>	<b>DESCRIPTION</b>
10	AE36-00003-0000	AUDIO CABLE ASSY. (SEE PG. 2-5)
11	A945-00059-0200	POWER CHASSIS: 130VA - SWITCHING (SEE PG. 2-17)
	AE89-00500-0000	CABINET ASSY. (INCLUDES ITEMS 12 & 13)
12	OE68-00500-0000	CABINET
13	A961-00007-0000	CASTER-WHEEL ASSY. (INCLUDES FOLLOWING 4 ITEMS) (2 REQ'D.)
	0017-00042-0255	CASTER WHEEL
	0017-00100-0037	E-RING .375
	0894-00702-00XF	CASTER - WHEEL SHAFT
	0961-00109-0000	WHEEL BRKT.
14	B084-91877-AE68	LAMP CONTROL P.C. BOARD ASSY.
15	OE36-00102-00XF	MONITOR RAIL (2 REQ'D.) (BEHIND REAR WALL OF CABINET)
16	B084-91787-AE89	8 TO 4 MULTIPLEX BD. ASSY.
17	B084-91870-A000	FCC - FILTER BD. ASSY.: MONOBOARD
18	0311-00100-0000	BEZEL MOUNTING BRKT. (2 REQ'D.) (BEHIND REAR WALL OF CABINET)
		<b>ADDITIONAL PARTS LIST</b>
	OE89-00300-0000	CATALOG: STAR GUARDS U.R. - 3 PLAYER
	M051-00E89-A007	TAG: OPTION SWITCH SETTINGS
	AE36-00009-0000	REAR DOOR ASSY. (INCLUDES FOLLOWING 6 ITEMS)
	OE36-00502-0000	REAR DOOR (WOOD)
	0017-00005-0050	DOOR LOCK W/2 INDIVIDUAL KEYS
	0017-00005-0209	LOCK PLATE (SCREW MTD.)
	0017-00009-0490	VENT GRILLE - 5-5/8 SQ. IN. (2 REQ'D.)
	0618-00117-00XF	PERFORATED VENT GRILLE (2 REQ'D.)
	0639-00116-00XF	CAM: OFFSET 30 DEGREES

HEADER FLUORESCENT LIGHT ASSY.-PARTS LIST  
 PART NO. A595-00011-0000

ORDER BY PART NUMBER ONLY

ITEM	PART NO.	DESCRIPTION
1	0595-00105-0000	FLUORESCENT BRKT.
2	0017-00003-0043	18" COOL WHITE FLUORESCENT LAMP
3	0017-00003-0445	LAMP LOCKS (2 REQ'D.)
4	0017-00031-0036	FLUORESCENT SOCKET (2 REQ'D.)
5	0017-00003-0412	FLUORESCENT STARTER HOLDER W/LEADS
	0017-00101-0347	#6-32 X 1/2 PHIL. RND. HD. M.S. (4 REQ'D.)
6	0017-00003-0019	FLUORESCENT STARTER
7	0017-00003-0026	BALLAST
	0017-00101-0598	#8-32 X 5/16 SLT. HEX HD. SCR. (4 REQ'D.)

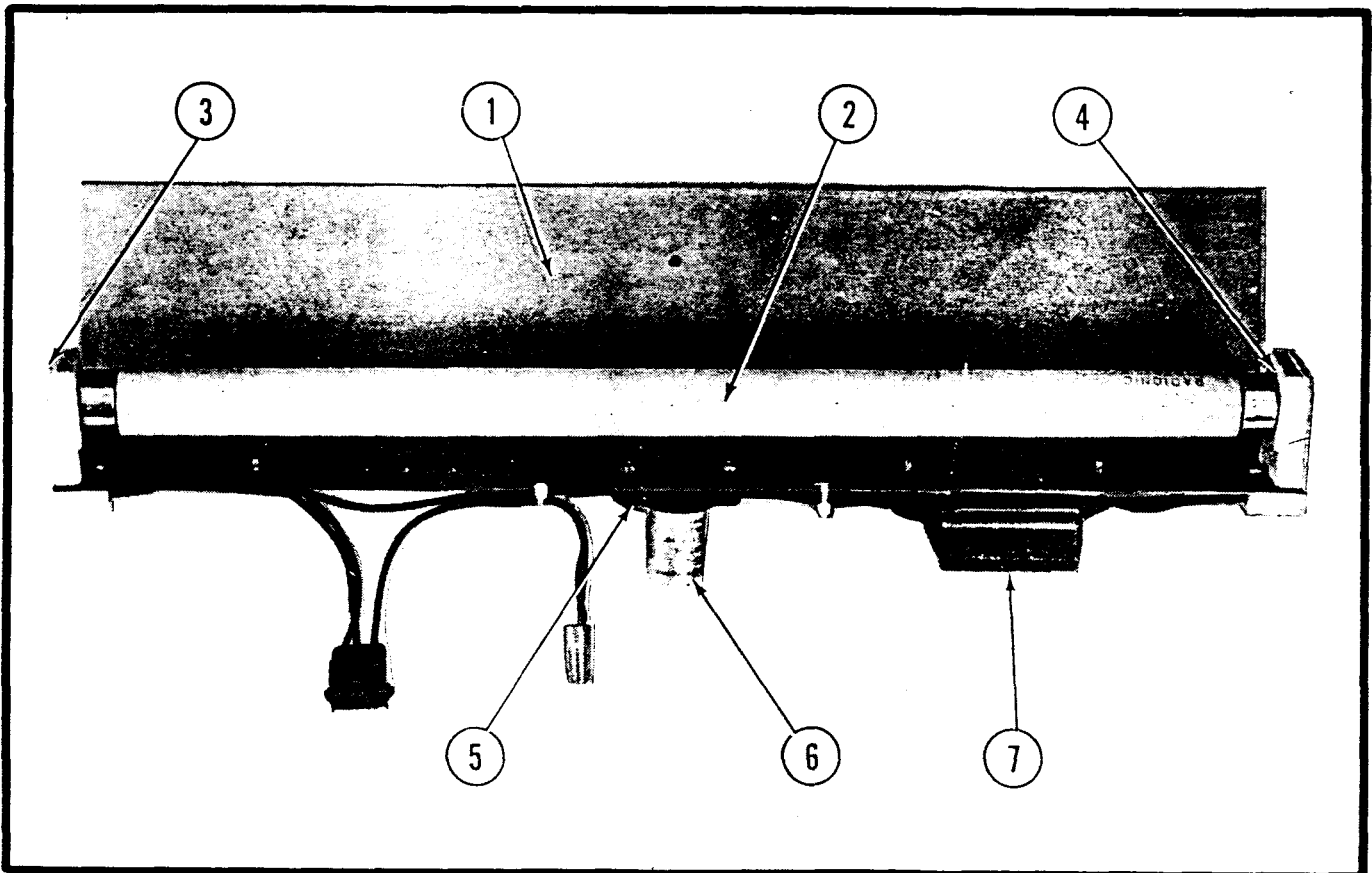

**JOYSTICK ASSY.: SHAFT & PLATE  
PART NO. AE36-00021-0000**

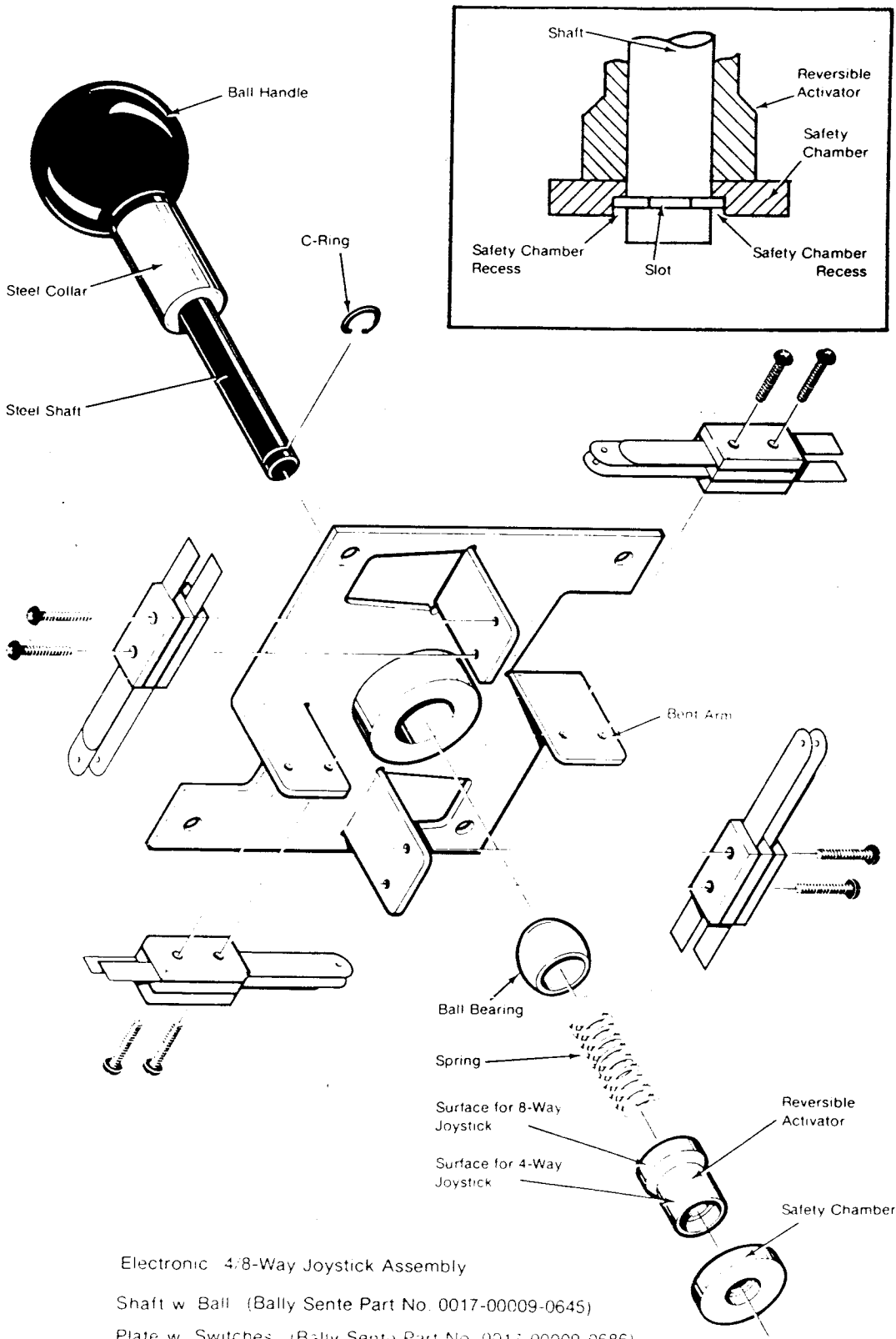

Electronic 4/8-Way Joystick Assembly

Shaft w Ball (Bally Sente Part No. 0017-00009-0645)

Plate w Switches (Bally Sente Part No. 0017-00009-0686)

COIN DOOR W/CABLE: BLACK 3-CHUTE  
PART NO. A982-00014-0021

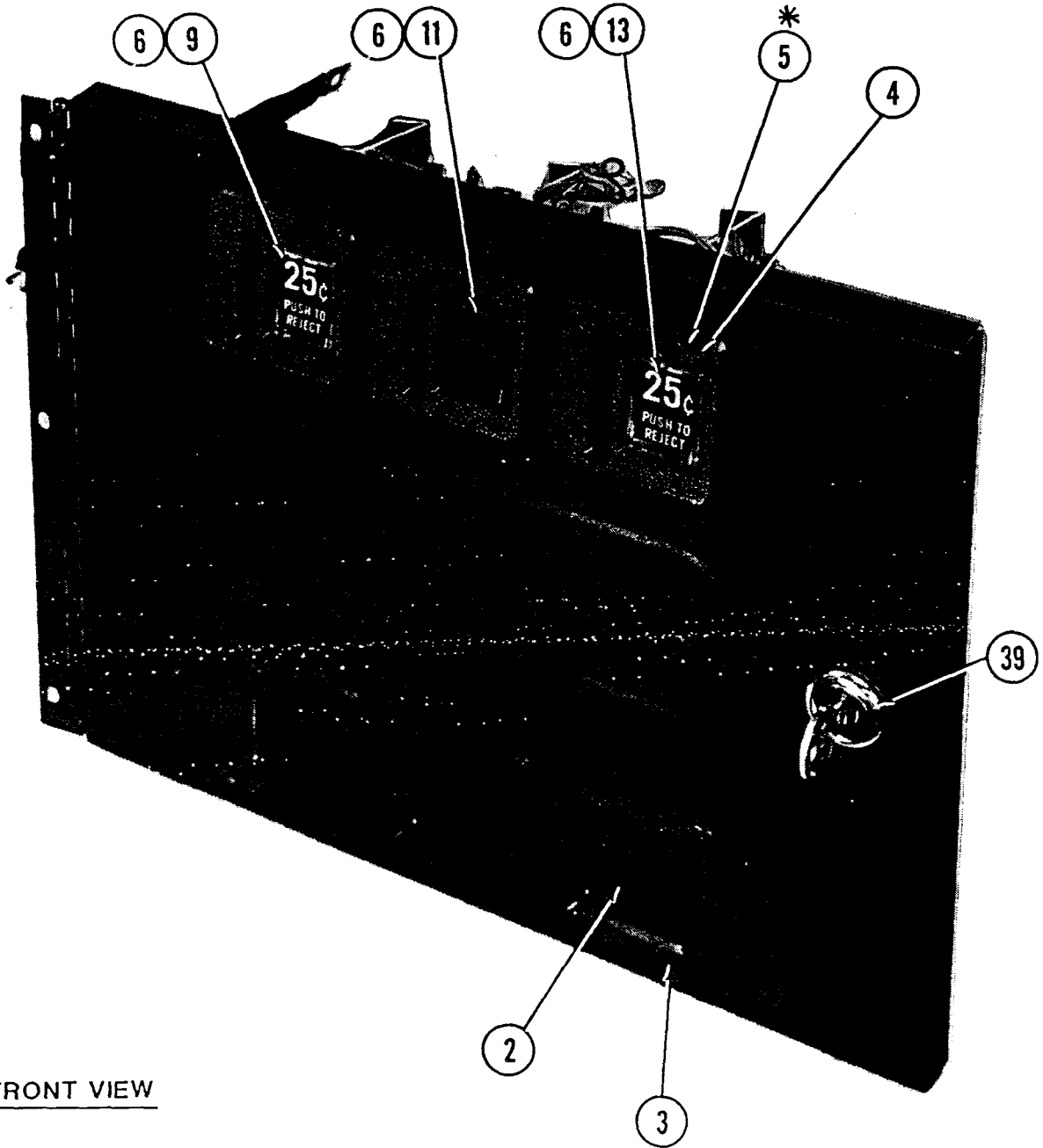

FRONT VIEW

\* NOT SHOWN

COIN DOOR W/CABLE: BLACK 3-CHUTE  
PART NO. A982-00014-0021

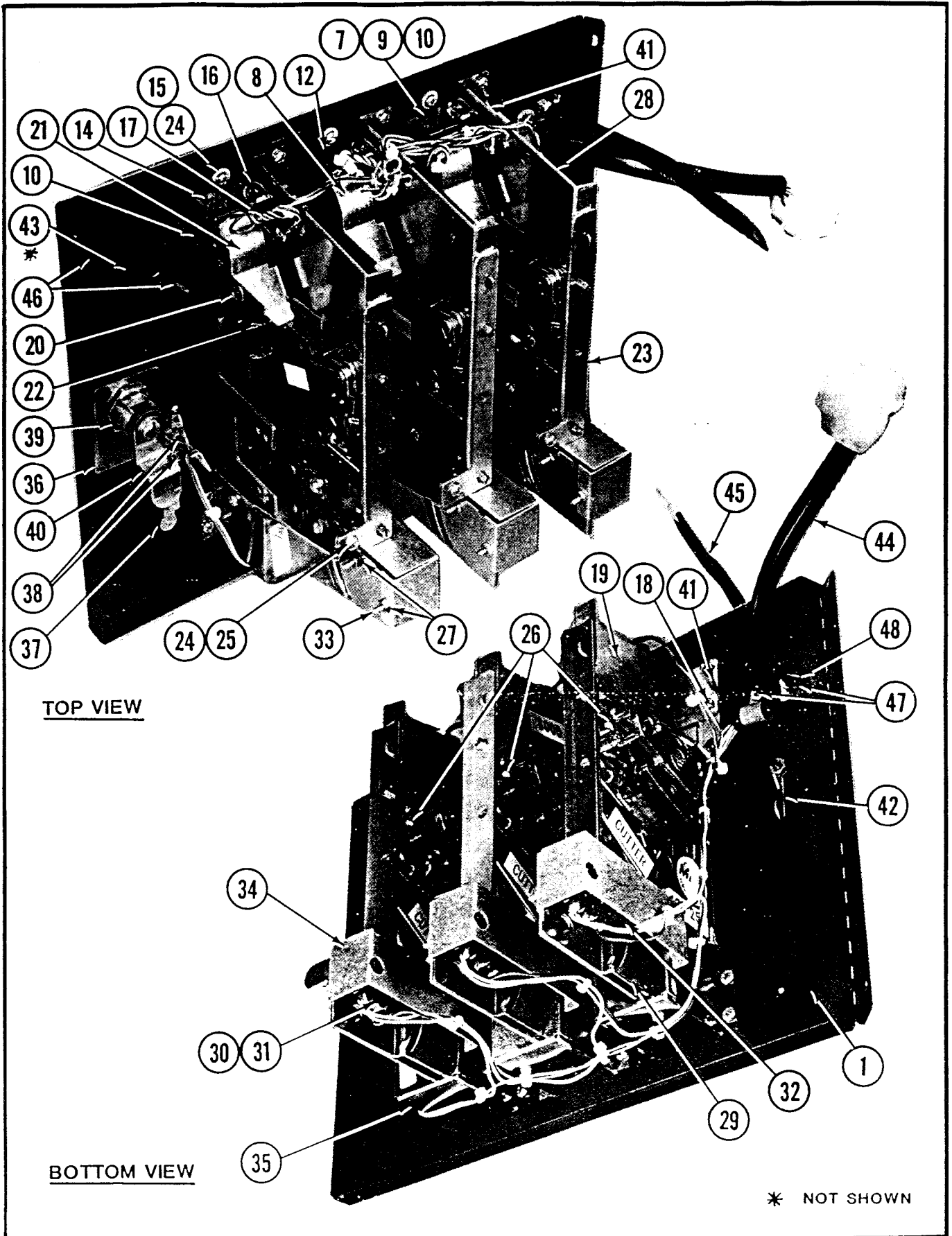

TOP VIEW

BOTTOM VIEW

\* NOT SHOWN



**COIN DOOR W/CABLE: BLACK 3-CHUTE - PARTS LIST, CONT'D.**  
**PART NO. A982-00014-0021**  
**ORDER FROM COIN MECHANISM BY PART NUMBER ONLY (312) 279-9150**

ITEM	PART NO.	DESCRIPTION
26	0017-00005-0003	COIN ACCEPTOR W/STRING CUTTER (3 REQ'D.) OR
26	0017-00005-0214	COIN ACCEPTOR W/STRING CUTTER
27	404-4	4-40 HEX NUT (6 REQ'D.)
28	8000-10	MECH. MTG. BRACKET "STAKED" (3 REQ'D.)
29	8000-18	SW. CHUTE (SMALL) (3 REQ'D.)
30	7300-134	SWITCH INSULATOR (3 REQ'D.)
31	7300-100-1	BLUE, SWITCH (3 REQ'D.)
32	8000-19	5¢ / 25¢ / SW. WIRE (3 REQ'D.)
33	101-4-16	4-4 X 1" ROUND HEAD MACHINE SCREW (6 REQ'D.)
34	8000-28	SWITCH COVER (3 REQ'D.)
35	8000-13	COIN RETURN CUP (3 REQ'D.)
36	8800-9-1-R	SLAM SWITCH BRACKET
37	7800-42	SLAM SWITCH
38	100-4-6	4-36 X 3/8 ROUND HEAD MACHINE SCREW (3 REQ'D.)
39	8800-24	DBL. BTD. LOCK & KEY W/NUTS
40	X615	LOCKING CAM
41	7800-7	KEY HOOK
42 *	0017-00007-0019	KEY HOOK
43 *	A090-00089-0000	COIN METER ASSY. W/DIODE
44 *	A982-00015-0011	COIN DOOR CABLE ASSY.
45 *	0017-00009-0609	GROUND STRAP: L = 7" W/BLACK COVER
46 *	0017-00103-0061	NUT: 8-32 HEX W/SEMS ST. (2 REQ'D.)
47 *	0017-00103-0084	NUT: 6-32 HEX W/SEMS ST. (2 REQ'D.)
48 *	0017-00104-0019	WASHER: 6 145 - .375 - 032 FLAT ST.
*		NOT PART OF ABOVE ASSEMBLY & MUST BE
		ORDERED SEPARATELY, THROUGH BALLY MIDWAY MFG. CO.

**COIN DOOR W/CABLE: BLACK 3-CHUTE - PARTS LIST, CONT'D.**  
**PART NO. A982-00014-0021**  
**ORDER FROM COIN MECHANISM BY PART NUMBER ONLY (312) 279-9150**

ITEM	PART NO.	DESCRIPTION
26	0017-00005-0003	COIN ACCEPTOR W/STRING CUTTER (3 REQ'D.) OR
26	0017-00005-0214	COIN ACCEPTOR W/STRING CUTTER
27	404-4	4-40 HEX NUT (6 REQ'D.)
28	8000-10	MECH. MTG. BRACKET "STAKED" (3 REQ'D.)
29	8000-18	SW. CHUTE (SMALL) (3 REQ'D.)
30	7300-134	SWITCH INSULATOR (3 REQ'D.)
31	7300-100-1	BLUE, SWITCH (3 REQ'D.)
32	8000-19	5¢ / 25¢ / SW. WIRE (3 REQ'D.)
33	101-4-16	4-4 X 1" ROUND HEAD MACHINE SCREW (6 REQ'D.)
34	8000-28	SWITCH COVER (3 REQ'D.)
35	8000-13	COIN RETURN CUP (3 REQ'D.)
36	8800-9-1-R	SLAM SWITCH BRACKET
37	7800-42	SLAM SWITCH
38	100-4-6	4-36 X 3/8 ROUND HEAD MACHINE SCREW (3 REQ'D.)
39	8800-24	DBL. BTD. LOCK & KEY W/NUTS
40	X615	LOCKING CAM
41	7800-7	KEY HOOK
42 *	0017-00007-0019	KEY HOOK
43 *	A090-00089-0000	COIN METER ASSY. W/DIODE
44 *	A982-00015-0011	COIN DOOR CABLE ASSY.
45 *	0017-00009-0609	GROUND STRAP: L = 7" W/BLACK COVER
46 *	0017-00103-0061	NUT: 8-32 HEX W/SEMS ST. (2 REQ'D.)
47 *	0017-00103-0084	NUT: 6-32 HEX W/SEMS ST. (2 REQ'D.)
48 *	0017-00104-0019	WASHER: 6 145 - .375 - 032 FLAT ST.
*		NOT PART OF ABOVE ASSEMBLY & MUST BE
		ORDERED SEPARATELY, THROUGH BALLY MIDWAY MFG. CO.

POWER CHASSIS: 130VA (SWITCHING)  
PART NO. A945-00059-0200

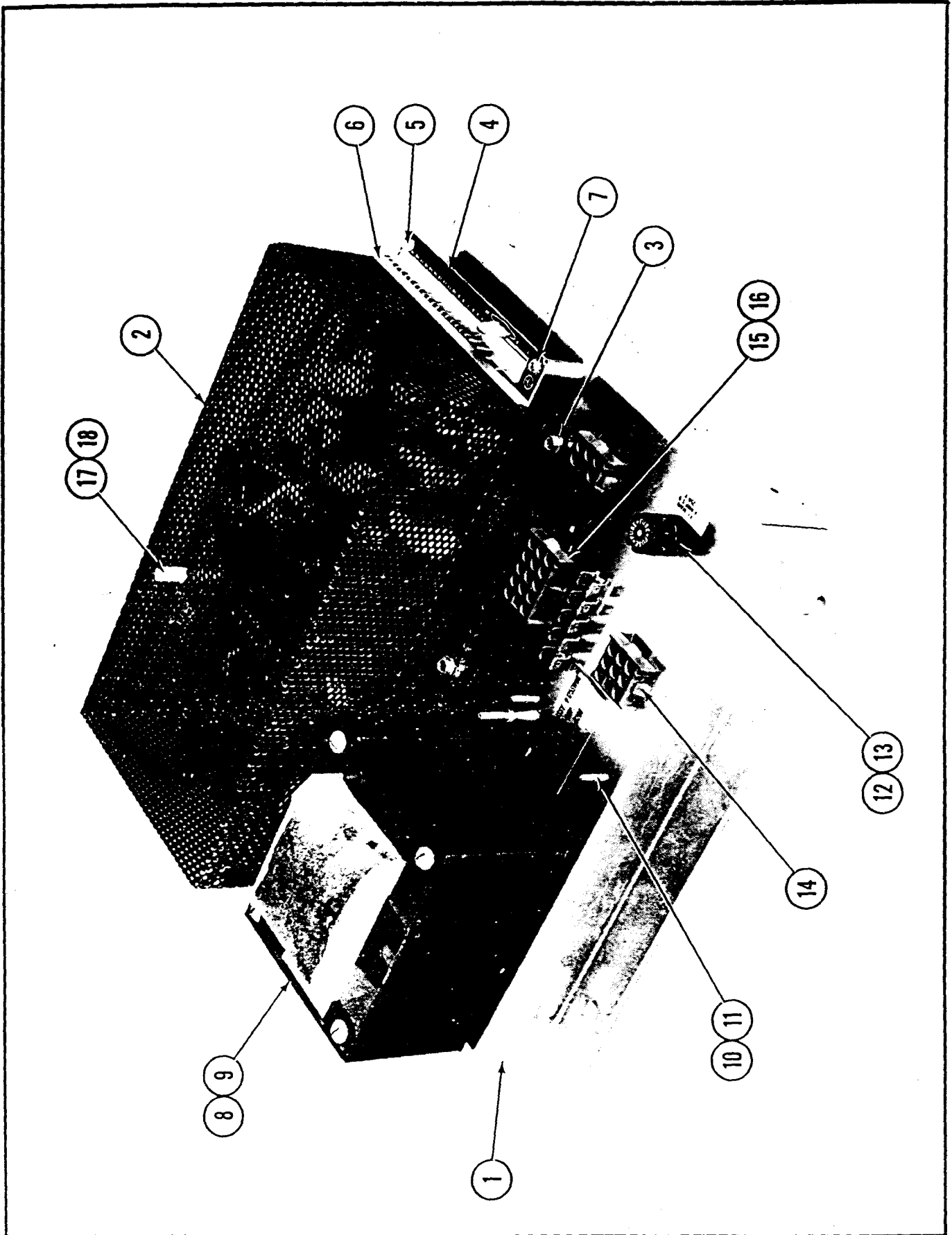

**POWER CHASSIS: 130VA (SWITCHING) PARTS LIST  
PART NO. A945-00059-0200**

ORDER BY PART NUMBER ONLY

ITEM	PART NO.	DESCRIPTION
1	A945-00057-01XF	CHASSIS SUB-ASSEMBLY
2	0945-00117-01XF	POWER SUPPLY COVER
3	0017-00101-0123	8 X 4 UNSLOT HEX HD. SCREW (8 REQ'D.)
4	0017-00003-0543	SWITCHING POWER SUPPLY - 125VA
5	0017-00042-0663	LOCKING P.C. BRD. SPACER (4 REQ'D)
6	0540-00138-2100	CABLE PROTECTOR - 5"
7	0017-00101-0134	6-32 X 4 PHIL. ROUND HD. SCREW
8	MT00-00136-A000	ISOLATION TRANSFORMER W/O SHIELD ASSY.-115V., 50/60 HZ.
9	0017-00103-0061	8-32 HEX NUT W/SEMS (4 REQ'D) (NOT SHOWN)
10	0017-00003-0114	LINE FILTER - 5 AMP, 115VAC (NOT SHOWN)
11	0017-00101-0067	6 X 6 PHL. PAN HD. (2 REQ'D)
12	0017-00003-0433	FUSE HOLDER
13	0017-00003-0263	FUSE MDA, 3AG, 4 AMP, 115 VAC
14	A945-00030-0600	CONNECTOR & CABLE ASSEMBLY
15	0017-00021-0370	TERMINAL STRIP
16	0017-00101-0140	4-40 X 5 PHL. PAN HD. SCREW (2 REQ'D)
17	0017-00009-0580	CAPACITOR ALIGNMENT TOOL
18	0945-00912-0000	ADJ. TOOL HANDLE
		<b>ADDITIONAL PARTS LIST</b>
	115E-00001-0004	VARISTOR-METAL OXIDE (UNDER CHASSIS)
	0017-00021-1110	2 POSITION TERMINAL BARRIER STRIP (UNDER CHASSIS)
	0017-00101-0780	6 X 8 PHIL. PAN HD. SCREW (UNDER CHASSIS)
	0017-00103-0084	6-32 HEX NUT W/SEMS (UNDER CHASSIS)

SECTION 3  
COMPONENT LAYOUTS,  
SCHEMATICS & WIRING DIAGRAM

## TYPICAL OSCILLOSCOPE WAVEFORM PATTERNS

The waveforms shown below were observed on a wide band oscilloscope. The input signal was from a crosshatch generator with a horizontal sync frequency of 15.73kHz and a vertical frequency of 60 Hz. If the waveforms are observed on an oscilloscope with a limited high frequency response, the corners of the pulses will tend to be more rounded than those shown, and the amplitude of any high frequency pulse will tend to be less.

Each photograph is numbered. These numbers correspond to the circled numbers on the schematic diagrams.

Photographs 12, 13, 14, 15 and 16 are of the red signal at various points along the red video channel. The waveforms at corresponding points along the green and blue video channels will look similar.

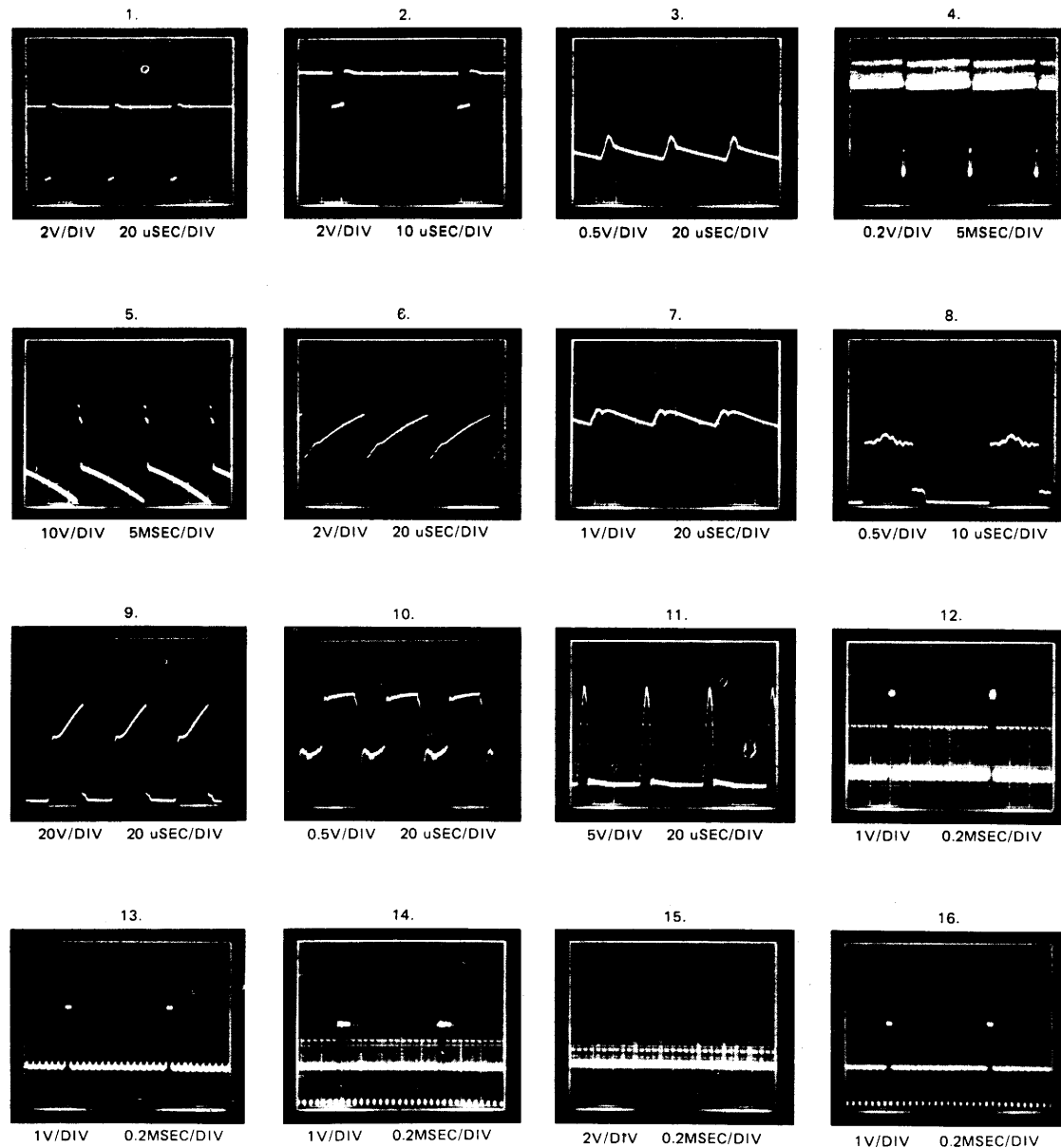

## TROUBLESHOOTING CHART

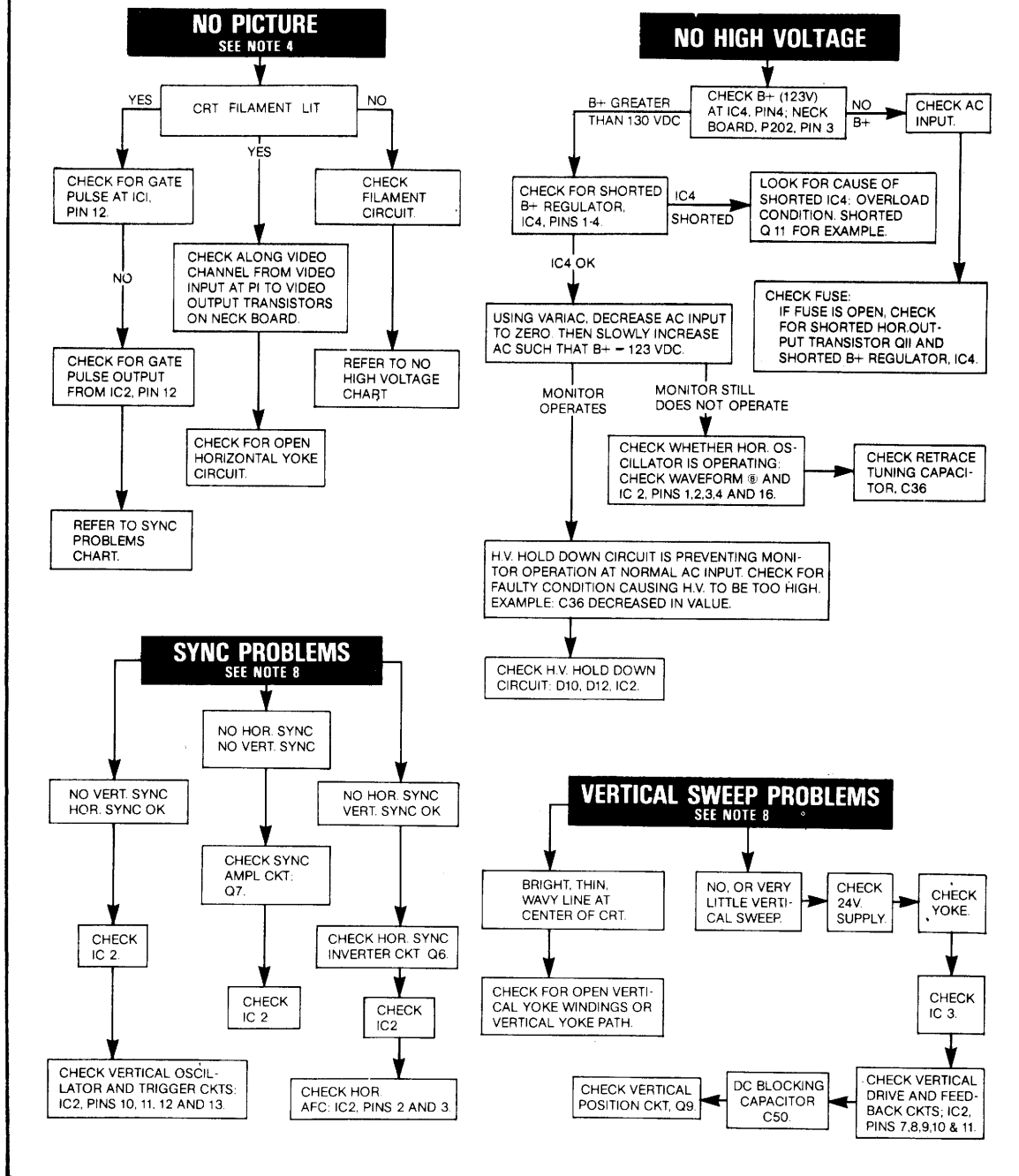

### TROUBLESHOOTING NOTES

- The troubleshooting chart mentions specific components to be checked. It is intended that the entire circuit associated with these components be checked.
- This chart is a guide to servicing rather than a complete list of each component that could fail. Therefore, troubleshooting should not be limited only to those components mentioned in the chart.
- It is always useful to begin checking a circuit by measuring the DC voltages and then comparing the measurements to those listed in the Typical DC Voltages chart.
- The cutoff controls and drive controls on the neck board and the screen control at the bottom of the flyback transformer have been preset at the factory. When servicing the monitor for a lack of video, do not adjust any of these controls unless it is suspected that the problem is a result of these controls having been tampered with. Otherwise do not adjust these controls; if they are so severely out of adjustment that there is a lack of video, then there is something malfunctioning.
- The Wells-Gardner Service Department does accept telephone calls for servicing assistance. Call 1-312-252-8220, between 7:00am and 3:30pm Central Time. Ask for the Service Department. The Service Department is closed during the first two weeks of July. Telephone assistance is not available during this period. Before calling, be sure to have available the model number of the monitor being serviced and the schematic diagram of the monitor being serviced.

- Replacement parts may be ordered from the Service Department between 7:00am and 4:30pm Central Time.

- All monitors are equipped with automatic degaussing coils which demagnetize the picture tube every time the monitor is turned on after being off for a minimum of 20 minutes. Should any part of the chassis become magnetized it will be necessary to degauss the affected area with a manual degaussing coil. Move the coil slowly around the CRT face area and all surrounding metal parts. Then slowly withdraw for a distance of 6 feet before turning off.

#### 8. Horizontal vs. Vertical:

Some models have the picture tube mounted vertically rather than horizontally. That is, the picture tube is mounted in the frame such that the long dimension of the tube is up and down. Examples of this include (but are not limited to) Models 13K7851 and 19K7951. Other than the physical orientation of the picture tube, there is no electrical difference between these models and their horizontal counterparts. The same circuits, the vertical circuits, produce and control deflection along the short dimension of the tube in all models.

The same circuits, the horizontal circuits, produce and control deflection along the long dimension of the tube in all models. Therefore, wherever "vertical" appears in this manual or on the monitor, it refers to the short dimension of the picture tube; wherever "horizontal" appears, it refers to the long dimension of the picture tube.

# K7000 COLOR MONITOR SCHEMATIC DIAGRAM

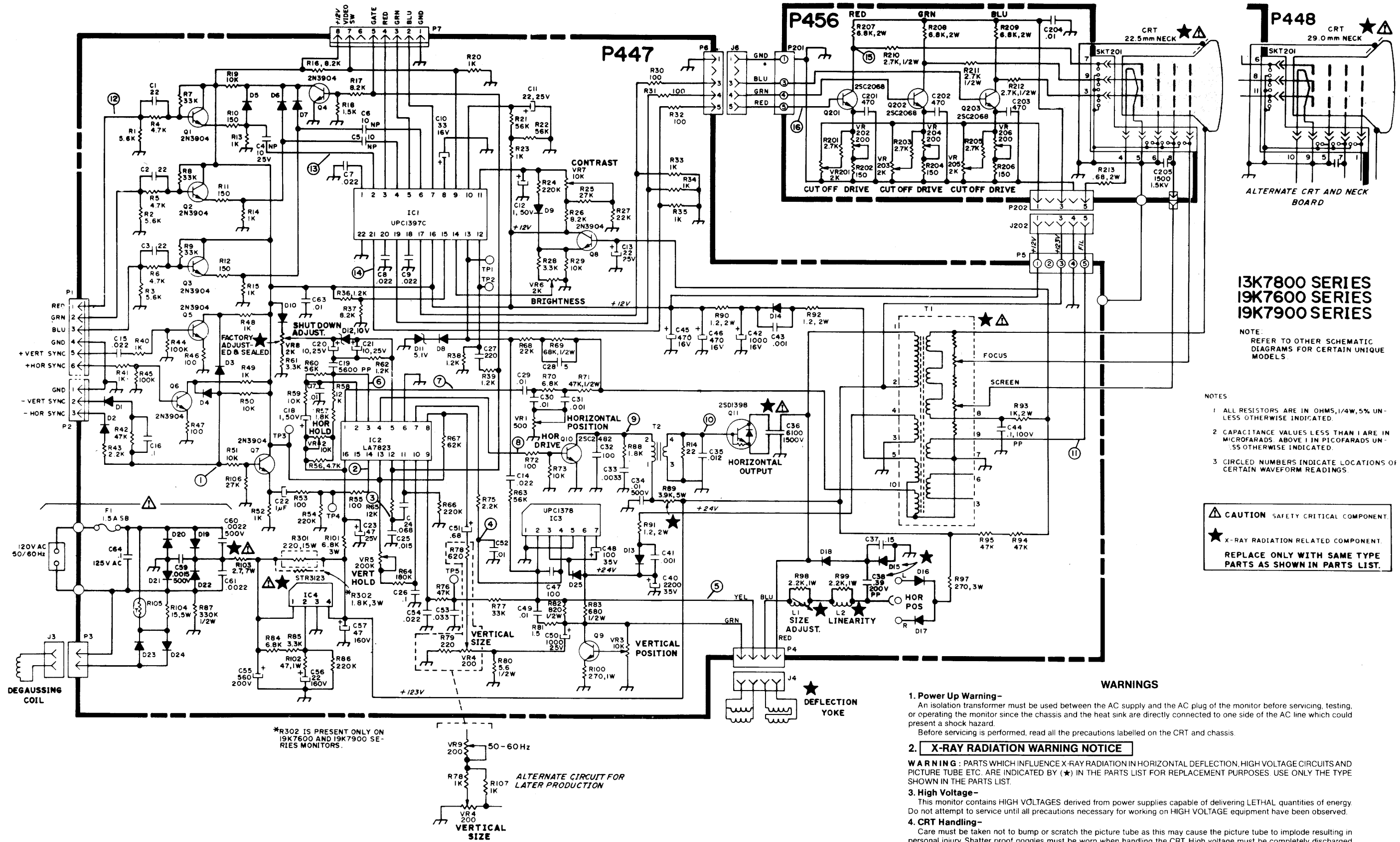

**13K7800 SERIES  
19K7600 SERIES  
19K7900 SERIES**

NOTE:  
REFER TO OTHER SCHEMATIC  
DIAGRAMS FOR CERTAIN UNIQUE  
MODELS.

- NOTES
- 1 ALL RESISTORS ARE IN OHMS, 1/4W, 5% UNLESS OTHERWISE INDICATED.
  - 2 CAPACITANCE VALUES LESS THAN 1 ARE IN MICROFARADS. ABOVE 1 IN PICOFARADS UNLESS OTHERWISE INDICATED.
  - 3 CIRCLED NUMBERS INDICATE LOCATIONS OF CERTAIN WAVEFORM READINGS.

**CAUTION** SAFETY CRITICAL COMPONENT.

**X-RAY RADIATION RELATED COMPONENT.**

REPLACE ONLY WITH SAME TYPE PARTS AS SHOWN IN PARTS LIST.

## WARNINGS

- 1. Power Up Warning-**  
An isolation transformer must be used between the AC supply and the AC plug of the monitor before servicing, testing, or operating the monitor since the chassis and the heat sink are directly connected to one side of the AC line which could present a shock hazard.  
Before servicing is performed, read all the precautions labelled on the CRT and chassis.
- 2. X-RAY RADIATION WARNING NOTICE**  
**WARNING:** PARTS WHICH INFLUENCE X-RAY RADIATION IN HORIZONTAL DEFLECTION, HIGH VOLTAGE CIRCUITS AND PICTURE TUBE ETC. ARE INDICATED BY (★) IN THE PARTS LIST FOR REPLACEMENT PURPOSES. USE ONLY THE TYPE SHOWN IN THE PARTS LIST.  
**AVERTISSEMENT:** POUR MAINTENIR LE DEGRE DE SECURITE DE L'APPAREIL NE REMPLACER LES COMPOSANTS DONT LE FONCTIONNEMENT EST CRITIQUE POUR LA SECURITE QUE PAR DES PIECES RECOMMANDEES PAR LE FABRICANT.
- 3. High Voltage-**  
This monitor contains HIGH VOLTAGES derived from power supplies capable of delivering LETHAL quantities of energy. Do not attempt to service until all precautions necessary for working on HIGH VOLTAGE equipment have been observed.
- 4. CRT Handling-**  
Care must be taken not to bump or scratch the picture tube as this may cause the picture tube to implode resulting in personal injury. Shatter proof goggles must be worn when handling the CRT. High voltage must be completely discharged before handling. Do not handle the CRT by the neck.
- 5. PRODUCT SAFETY NOTICE**  
**WARNING:** FOR CONTINUED SAFETY REPLACE SAFETY CRITICAL COMPONENTS ONLY WITH MANUFACTURER RECOMMENDED PARTS. THESE PARTS ARE IDENTIFIED BY SHADING AND BY (Δ) ON THE SCHEMATIC DIAGRAM.  
**AVERTISSEMENT:** POUR MAINTENIR LE DEGRE DE SECURITE DE L'APPAREIL NE REMPLACER LES COMPOSANTS DONT LE FONCTIONNEMENT EST CRITIQUE POUR LA SECURITE QUE PAR DES PIECES RECOMMANDEES PAR LE FABRICANT.  
For replacement purposes, use the same type or specified type of wire and cable, assuring the positioning of the wires is followed (especially for H.V. and power supply circuits). Use of alternative wiring or positioning could result in damage to the monitor or in a shock or fire hazard.

## VIDEO INTERFACE AND OUTPUT

The red, green, and blue video inputs come into the monitor at P1. Isolation and attenuation is provided by emitter followers Q1, Q2 and Q3. Forced blanking of the video signals is provided by the circuit of Q4, D5, D6, and D7. The forced blanking causes there to be an interruption in the video signal before it goes to the inputs of IC1. This interruption occurs between scan periods, while retrace is taking place; it is required by IC1. The forced blanking is not necessary for most video signals since they already have an interruption of video (blanking) between scan periods. Some do not; it is to accommodate such signals that the forced blanking circuit is included.

The red, green, and blue signals go into IC1 at pins 2, 4, and 6. Their levels are controlled by the gain of separate channels of the contrast amplifier. The gain is controlled by a DC voltage input to pin 11, which varies with the setting of the contrast control.

IC1 provides blanking of the video during retrace in response to blanking pulses at pin 13, derived from the horizontal and vertical sweep circuits. IC1 also requires a gating signal at pin 12 in order to provide red, green, and blue outputs at pins 21, 19, and 17. If the gating signal is not present, IC1 will not provide video output signals. The gating signal comes from IC2, pin 12 and is derived from horizontal sync.

The brightness is varied by varying the DC level of the outputs at pins 17, 19, and 21. This is accomplished by varying the DC voltage input to pin 14.

The video outputs from IC1 are provided via R30, R31, and R32 to the neck board where they are amplified by the video output stages Q201, Q202, and Q203 before being applied to the cathodes of the CRT through R10, R11, and R12.

## SYNC

Sync is applied at P1 (positive sync) or at P2 (negative sync). Composite sync should be applied only to the horizontal sync input of the appropriate polarity. Positive sync is inverted by Q5 and Q6 then applied through D3, D4 and R51 to the sync amplifier Q7.

The sync amplifier output is applied through C22, R53, and R55 to pin 14 of IC2. Pin 14 is the sync separation input.

The sync separator extracts the horizontal and vertical sync from each other—providing horizontal sync to the horizontal AFC circuit in the IC. A composite sync output is provided at pin 12. This output signal is used for gating IC1 the video interface IC and for triggering the vertical oscillator.

## HORIZONTAL OSCILLATOR AND OUTPUT

The horizontal AFC circuit of IC2 receives a horizontal sync input from the sync separator and a feedback signal at pin 1, derived from the horizontal output. Slight differences in frequency and phase of the two signals will cause the AFC to generate a correction voltage at pin 2.

The horizontal oscillator in IC2 has its free running frequency determined by the RC time constant of C19, R56, R57, R58, and VR2, the horizontal hold control. The horizontal hold control varies the horizontal frequency by varying the RC time constant. Slight correction in frequency is provided by a correction voltage at IC2, pin 3 which comes from pin 2 through R60.

The oscillator output at pin 4 is amplified and shaped by the horizontal drive stage Q10. The drive signal is then coupled to the base circuit of the horizontal output transistor Q11 by the horizontal drive transformer T2. T2 is used for impedance transformation to provide the Q11 base circuit with the low impedance source that it requires.

The horizontal output transistor Q11 is operated as a switch. It is either on or off. It is turned on and off at the scan rate which is determined by the horizontal oscillator frequency which is ultimately determined by the incoming horizontal sync frequency. A yoke current with a sawtooth waveform is needed to deflect the beam linearly across the CRT. The beam begins at the center of the CRT and is deflected from center to right. This center-to-right deflection occurs when Q11 is turned on. The deflection yoke coupling capacitor C38, also known as the S-shaping capacitor, begins to discharge through the yoke; the discharge current causes the beam to be deflected to the right CRT edge. At this time, Q11 is turned off, and the current provided by C38 stops. As the current falls to zero, a voltage is induced across the yoke windings as the magnetic field collapses; an oscillation is produced by the yoke windings and C36, the retrace tuning capacitor. During the first half cycle of oscillation, the induced voltage is impressed on the collector of Q11, C36, and the primary of the flyback transformer T1. This induced voltage is stepped up by the flyback transformer's secondary winding. This high voltage is then rectified and applied to the high voltage anode of the CRT. When this induced voltage occurs, the electron beam is deflected from the right edge of the CRT face to the left edge. This is called retrace. During the second half cycle of the oscillation (of C36 and the yoke windings), the voltage at the Q11 collector tries to go negative or below ground. When this happens, the damper diode (include in same package with Q11) becomes forward biased. The conduction of the damper diode allows energy stored in the horizontal system to decay linearly to zero, thus allowing the beam to return to the center of the CRT face.

The focus voltage and the screen, G2, voltage are obtained from the anode voltage with a resistor divider network within the T1 assembly. An auxiliary winding (pin 10) provides feedback to the horizontal AFC through R71, R70, and C29. This signal is also used to furnish the horizontal blanking input to IC1 via C28, R69, and R68. The signal from the auxiliary winding at pin 5 of T1 is rectified by D14 and filtered to provide the +12VDC supply for the video interface and sync circuits. The auxiliary winding of pins 3 and 4 produces a signal which is rectified by D13 and filtered to produce the +24VDC supply for the vertical output circuit.

The horizontal linearity coil L2 is a magnetically biased coil which shapes the yoke current for optimum linearity. The horizontal size coil L1 is a variable series inductor which is used to vary the horizontal size of the display.

## HIGH VOLTAGE HOLD-DOWN CIRCUIT

The high voltage hold down circuit is part of the main PC board P447 of this monitor. The +12V DC supply is sensed via D10. Since the +12V DC supply is flyback pulse derived, the +12V DC supply will rise as the high voltage rises. If the +12V DC exceeds a threshold which is set with VR8, then D12 will conduct, thereby providing drive to IC2, pin 5—holddown input of deflection oscillator IC. The drive being applied to pin 5 causes the horizontal oscillator within the IC to shut down—thus preventing the generation of high voltage.

The horizontal oscillator will remain in its OFF state, even if the input to IC2, pin 5 is removed, unless and until AC power is removed from the monitor input. The power may then be reapplied.

## VERTICAL OSCILLATOR AND OUTPUT

The composite sync output of IC2, pin 12 is filtered through the network of R65, C25, C24 and R66 so that only vertical sync is applied to the vertical trigger input at pin 11. The vertical oscillator frequency is controlled by the vertical hold control and its input to pin 10.

The vertical drive output at IC2, pin 7 is applied to pin 4 of IC3, the vertical output IC. Output current from IC3, pin 2 flows through the yoke to cause vertical deflection. During upward deflection, current flows out of pin 2, through the yoke, and into C50 to charge it. Downward deflection is caused by C50 discharging through the yoke in the opposite direction and back into IC3, pin 2. AC feedback is provided through the wiper of the vertical size control VR4 to IC2, pin 8 in order to control the drive amplitude. DC feedback at IC2, pin 9 maintains good vertical linearity at all sizes.

DC current from the +24V supply flows through R83 and through the yoke to provide downward raster shift. Some of this DC current is diverted from the yoke through the collector of Q9. The amount of this current which is diverted from the yoke can be varied by varying the base drive to Q9 by adjusting VR3, the vertical position control, thus providing manual adjustment of the vertical position of the display.

The drive signal at IC3, pin 2 is also used to furnish the vertical blanking input to IC1, pin 13 via R63 and C14.

## AUTOMATIC DEGAUSSING ADG

The ADG circuit automatically demagnetizes the CRT. This circuit is activated only when the monitor is initially powered up after having been off for at least 20 minutes.

R105 is a positive temperature coefficient device. When it is cold, it has a very low resistance. As it gets warm, its resistance increases. If the monitor is cold when AC power is applied, then R105 with a low resistance allows current to pass through it, D23, D24, and the degaussing coil. As current flows through R105, it heats up and eventually has a very high resistance, allowing very little current to flow through it. The residual current now flowing through R105 produces a voltage drop across R104 of less than 0.6 volts. This is not enough to forward bias D23 and D24, so there is no current through the degaussing coil.

The process of initially having a large current through the degaussing coil and then having the current decay to zero is what produces the degaussing action. The degaussing current decays to zero before the CRT warms up, so the degaussing is completed before the picture comes on.





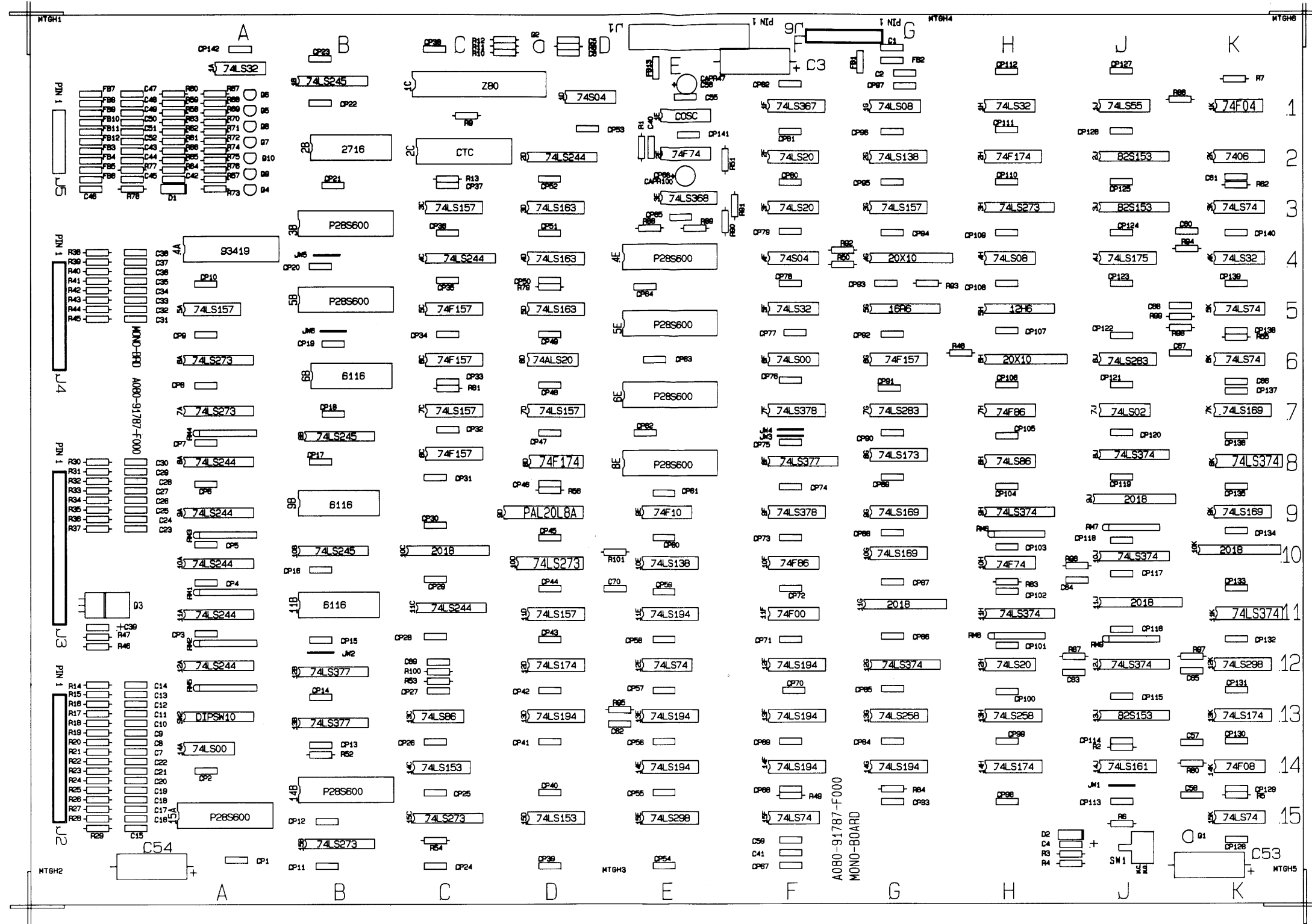

REVISED FOR PRODUCTION *1/2/86*

PROJECT ENG:		USED ON:		BALLY/MIDWAY MFG. CO.	
DO NOT SCALE DWG.		NO. RECD:		FRANKLIN PARK ILL.	
DRN. JS	HEAT TREAT	NON-SCROLL MONO BD.		PART NO.	
CKD. C.M.M.	MATL.	A084-91787-F000		M051-00114-F128	
DATE 07/25/86	FINISH				



MONOBOARD  
A084-91787-F000  
M051-00114-F156

CROSS REFERENCE LIST:

<u>DESCRIPTION</u>	<u>QTY</u>	<u>DESIGNATION NO.</u>	<u>PART NO.</u>
SWITCH PC. MIG.	1	SW1	0986-00804-3100
10 POS. DIP SWITCH	1	SW2	113E-00001-0004
SNAP	1	MHQ3	0017-00007-0134
PC BOARD	1		A080-91787-F000

DESIGNATION LIST:

<u>DESCRIPTION</u>	<u>DESIGNATION NO.</u>
CP1-CP65	.01 UF AX. CER.
CP66	100 UF 16V RD. TANT
CP67-CP142	.01UF AX. CER.
C1,C2	390 PF AX. CER.
C3	470 UF 16V AX. ELEC.
C4	10 UF 25V AX. TANT.
C5	33 PF AX. CER.
C6-C38	.1 UF AX. CER.
C39	10 UF 25V AX. TANT.
C40	.01 UF AX. CER
C41,C42	390 PF AX. CER.
C43-C46	820 PF AX. CER.
C47-C52	47 PF AX. CER.
C53,C54	470 UF 16V AX. ELEC.
C55	390 PF AX. CER.
C56	47 UF 25V RD. TANT.
C57	68 PF AX. CER.
C58,C59	.01 UF AX. CER.
C60	18 PF AX. CER.
C61	.01 UF AX. CER.
C62	18 PF AX. CER.
C63	68 PF AX. CER.
C64	68 PF AX. CER.
C65	33 PF AX. CER.
C66	.01 UF AX. CER.
C67	18 PF AX. CER.
C68	18 PF AX. CER.
C69	270 PF AX. CER
C70	270 PF AX. CER
R1,R2	4.7K OHM 1/4W 5% CRBN.
R3,R4	10K OHM 1/4W 5% CRBN.
R5-R7	4.7K OHM 1/4W 5% CRBN.
R8	82K OHM 1/4W 5% CRBN.
R9	82 OHM 1/4W 5% CRBN.
R10-R13	4.7K OHM 1/4W 5% CRBN.
R14-R45	220 OHM 1/4W 5% CRBN.
R46,R47	2.7K OHM 1/4W 5% CRBN.
R48	22 OHM 1/4W 5% CRBN.
R49,R52-R56	4.7K 1/4W 5% CRBN.
R50,R51	68 OHM 1/4W 5% CRBN.
R57	560 OHM 1/4W 5% CRBN.
R58,R59	10 OHM 1/4W 5% CRBN.
R60	470 OHM 1/4W 5% CRBN.
R61,R62	10 OHM 1/4W 5% CRBN.
R63	470 OHM 1/4W 5% CRBN.
R64,R65	10 OHM 1/4W 5% CRBN.
R66	470 OHM 1/4W 5% CRBN.
R67	2K OHM 1/4W 5% CRBN.
R68	1K OHM 1/4W 5% CRBN.
R69	510 OHM 1/4W 5% CRBN.
R70	2K OHM 1/4W 5% CRBN.

DESIGNATION LIST:

<u>DESCRIPTION</u>	<u>DESIGNATION NO.</u>
R71	1K OHM 1/4W 5% CRBN.
R72	510 OHM 1/4W 5% CRBN.
R73	1K OHM 1/4W 5% CRBN.
R74	2K OHM 1/4W 5% CRBN.
R75	1K OHM 1/4W 5% CRBN.
R76	510 OHM 1/4W 5% CRBN.
R77,R78	560 OHM 1/4W 5% CRBN.
R79	4.7K OHM 1/4W 5% CRBN.
R80	82 OHM 1/4W 5% CRBN.
R81-R84	4.7K OHM 1/4W 5% CRBN.
R86	1K OHM 1/4W 5% CRBN.
R87	82 OHM 1/4W 5% CRBN.
R88	47 OHM 1/4W 5% CRBN.
R89	47 OHM 1/4W 5% CRBN.
R90	47 OHM 1/4W 5% CRBN.
R91	68 OHM 1/4W 5% CRBN.
R92	68 OHM 1/4W 5% CRBN.
R93	47 OHM 1/4W 5% CRBN.
R94	680 OHM 1/4W 5% CRBN.
R95	680 OHM 1/4W 5% CRBN.
R96	82 OHM 1/4W 5% CRBN.
R97	82 OHM 1/4W 5% CRBN.
R98	680 OHM 1/4W 5% CRBN.
R99	680 OHM 1/4W 5% CRBN.
R100	82 OHM 1/4W 5% CRBN.
R101	82 OHM 1/4W 5% CRBN.
RM1-RM4	2.7K OHM 10 PIN SIP
RM5	4.7K OHM 10 PIN SIP
RM6-RM9	1K OHM 9 PIN SIP
D1,D2	1N4148 DIODE
Q1	2N4123 XSTR.
Q2	2N4403 XSTR.
Q3	TIP110 XSTR.
Q4	2N4123 XSTR.
Q5-Q10	MPSA70 XSTR.
IC 1A	74LS32
IC 4A	93419 64x9 RAM
IC 5A	74LS157
IC 6A,7A	74LS273
IC 8A-12A	74LS244
IC 14A	74LS00
IC 15A	BG0 64K ROM/EPROM
IC 1B	74LS245
IC 2B	NOT USED
IC 3B,5B	PROG0,PROG1 256K ROM/EPROM
IC 6B	6116 2Kx8 RAM 150 NS.
IC 8B	74LS245
IC 9B	6116 2Kx8 RAM 150 NS.
IC 10B	74LS245

MONOBOARD  
A084-91787-F000  
M051-00114-F156

DESIGNATION LIST:

<u>DESCRIPTION</u>	<u>DESIGNATION NO.</u>
IC 11B	6116 2Kx8 RAM 120 NS.
IC 12B,13B	74LS377
IC 14B	BG1 64K ROM/EPROM
IC 15B	74LS273
IC 1C	Z80B CPU
IC 2C	Z80B CTC
IC 3C	74LS157
IC 4C	74LS244
IC 5C,6C	74F157
IC 7C	74LS157
IC 8C	74F157
IC 10C	2018 2Kx8 RAM 55NS
IC 11C	74LS244
IC 13C	74LS86
IC 14C	74LS153
IC 15C	74LS273
IC 1D	74S04
IC 2D	74LS244
IC 3D-5D	74LS163
IC 6D	74ALS20
IC 7D	74LS157
IC 8D	74F174
IC 9D	Colarb Rl Pal
IC 10D	74LS273
IC 11D	74LS157
IC 12D	74LS174
IC 13D	74LS194
IC 15D	74LS153
IC 1E	20 MHZ COSC.
IC 2E	74F74
IC 3E	74LS368
IC 4E-6E,8E	FG3,FG2,FG1,FG0 256K ROM/EPROM
IC 9E	74F10
IC 10E	74LS138
IC 11E	74LS194
IC 12E	74LS74
IC 13E,14E	74LS194
IC 15E	74LS298
IC 1F	74LS367
IC 2F,3F	74LS20
IC 4F	74S04
IC 5F	74LS32
IC 6F	74LS00
IC 7F	74LS378
IC 8F	74LS377
IC 9F	74LS378
IC 10F	74F86
IC 11F	74F00
IC 12F-14F	74LS194
IC 15F	74LS74

DESIGNATION LIST:

<u>DESCRIPTION</u>	<u>DESIGNATION NO.</u>
IC 1G	74LS08
IC 2G	74LS138
IC 3G	74LS157
IC 4G	MMC01A HAL
IC 5G	MMC03B HAL
IC 6G	74F157
IC 7G	74LS283
IC 8G	74LS173
IC 9G,10G	74LS169
IC 11G	2018 2Kx8 RAM 45NS
IC 12G	74LS374
IC 13G	74LS258
IC 14G	74LS194
IC 1H	74LS32
IC 2H	74F174
IC 3H	74LS273
IC 4H	74LS08
IC 5H	PAL
IC 6H	MMC02B HAL
IC 7H	74F86
IC 8H	74LS86
IC 9H	74LS374
IC 10H	74F74
IC 11H	74LS374
IC 12H	74LS20
IC 13H	74LS258
IC 14H	74LS174
IC 1J	74LS55
IC 2J	PACNS REV 1.0 PLA
IC 3J	PACOUT REV 1.0 PLA
IC 4J	74LS175
IC 6J	74LS283
IC 7J	74LS02
IC 8J	74LS374
IC 9J	2018 2Kx8 RAM 45NS
IC 10J	74LS374
IC 11J	2018 2Kx8 RAM 45NS
IC 12J	74LS374
IC 13J	ROMCTRL REV 1.0 PLA
IC 14J	74LS161
IC 1K	74F04
IC 2K	7406
IC 3K	74LS74
IC 4K	74LS32
IC 5K,6K	74LS74
IC 7K	74LS169
IC 8K	74LS374
IC 9K	74LS169
IC 10K	2018 2Kx8 RAM 45NS
IC 11K	74LS374

DESIGNATION LIST:

<u>DESCRIPTION</u>	<u>DESIGNATION NO.</u>
IC 12K	74LS298
IC 13K	74LS174
IC 14K	74F08
IC 15K	74LS74
ICS 4A,15A,3B,5B	28 PIN IC SOCKET (.600)
ICS 6B,9B,11B	24 PIN IC SOCKET (.600)
ICS 14B	28 PIN IC SOCKET (.600)
ICS 1C	40 PIN IC SOCKET (.600)
ICS 2C	28 PIN IC SOCKET (.600)
ICS 10C	24 PIN IC SOCKET (.300)
ICS 9D	24 PIN IC SOCKET (.300)
ICS 3E	16 PIN IC SOCKET (.300)
ICS 4E-6E,8E	28 PIN IC SOCKET (.600)
ICS 4G	24 PIN IC SOCKET (.300)
ICS 5G	20 PIN IC SOCKET (.300)
ICS 11G	24 PIN IC SOCKET (.300)
ICS 5H	20 PIN IC SOCKET (.300)
ICS 6H	24 PIN IC SOCKET (.300)
ICS 2J,3J	20 PIN IC SOCKET (.300)
ICS 9J,11J	24 PIN IC SOCKET (.300)
ICS 13J	20 PIN IC SOCKET (.300)
ICS 10K	24 PIN IC SOCKET (.300)
FB1-FB13	FERRITE BEAD
SW1	SWITCH PC. MITG.
SW2	10 POS. DIP SWITCH
JW1-JW6	JUMPER
J1	AUTO INSERT PINS TIN .045 SQ. PIN
J2-J6	AUTO INSERT PINS TIN .025 SQ. PIN
MHQ3	SNAP
PC BOARD	A080-91787-F000

Released 12 Sept. 86 CMM  
Rev. 1 - 20 Nov. 86 moved 5H to chart. CMM

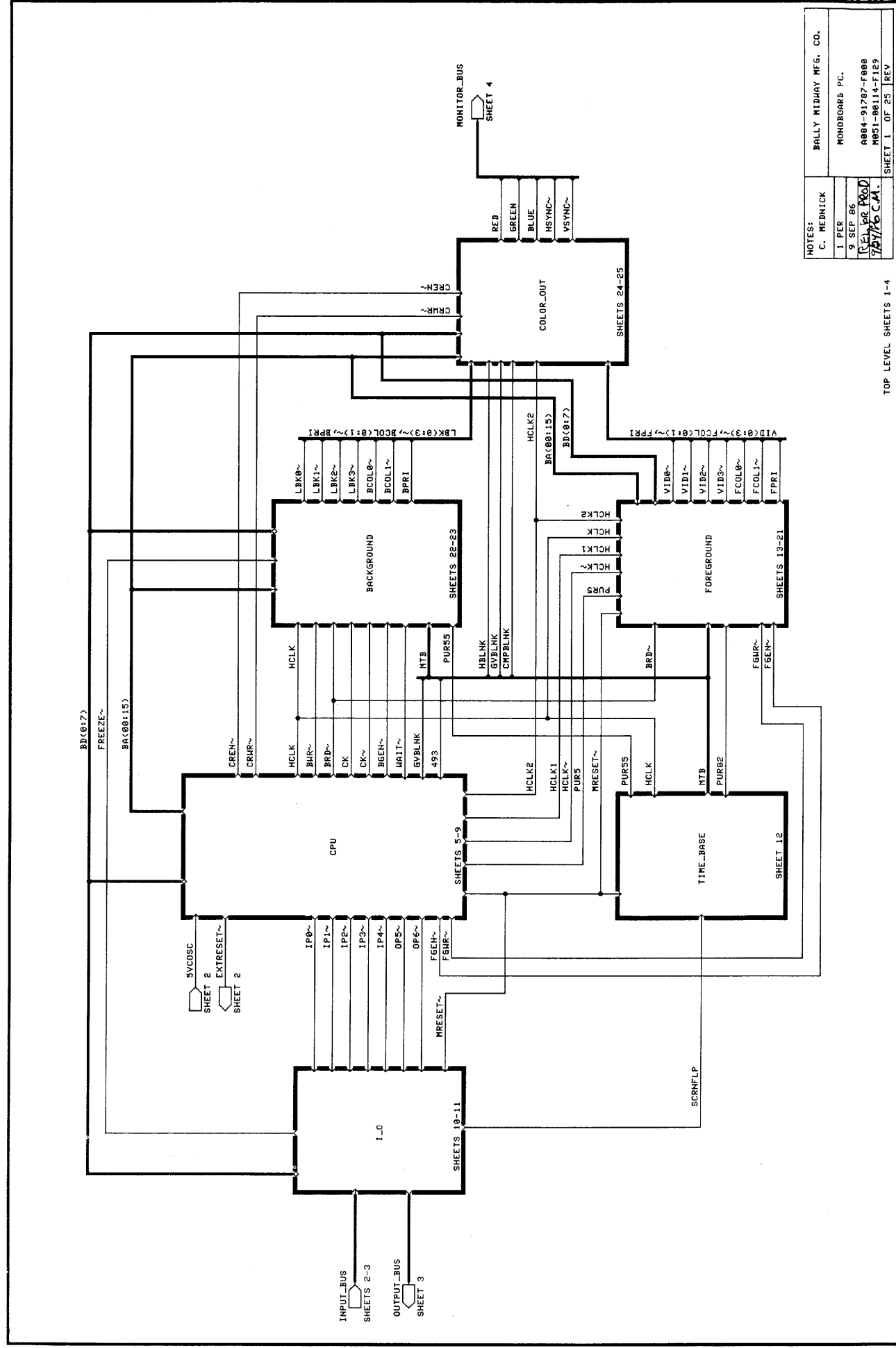

NOTES:  
 C. REDNICK  
 1 PER  
 9 SEP 86  
 BALLY MFG. CO.  
 MONOBOARD PC.  
 A884-91787-F888  
 M851-88114-F129  
 7/27/86 C.M.  
 SHEET 1 OF 25 REV

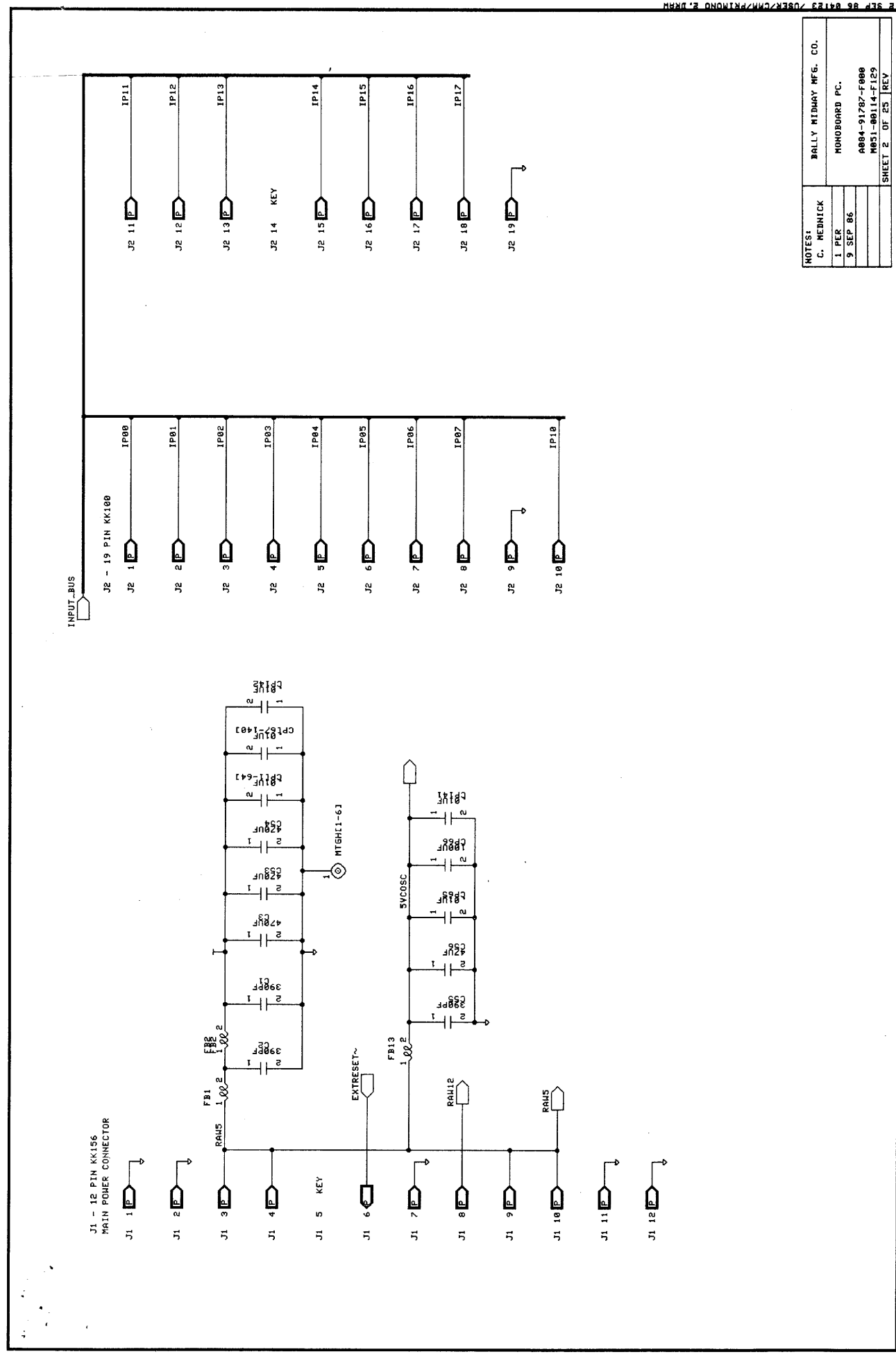

NOTES:  
 C. REDNICK  
 1 PER  
 9 SEP 86  
 BALLY MFG. CO.  
 MONOBOARD PC.  
 A884-91787-F888  
 M851-88114-F129  
 SHEET 2 OF 25 REV

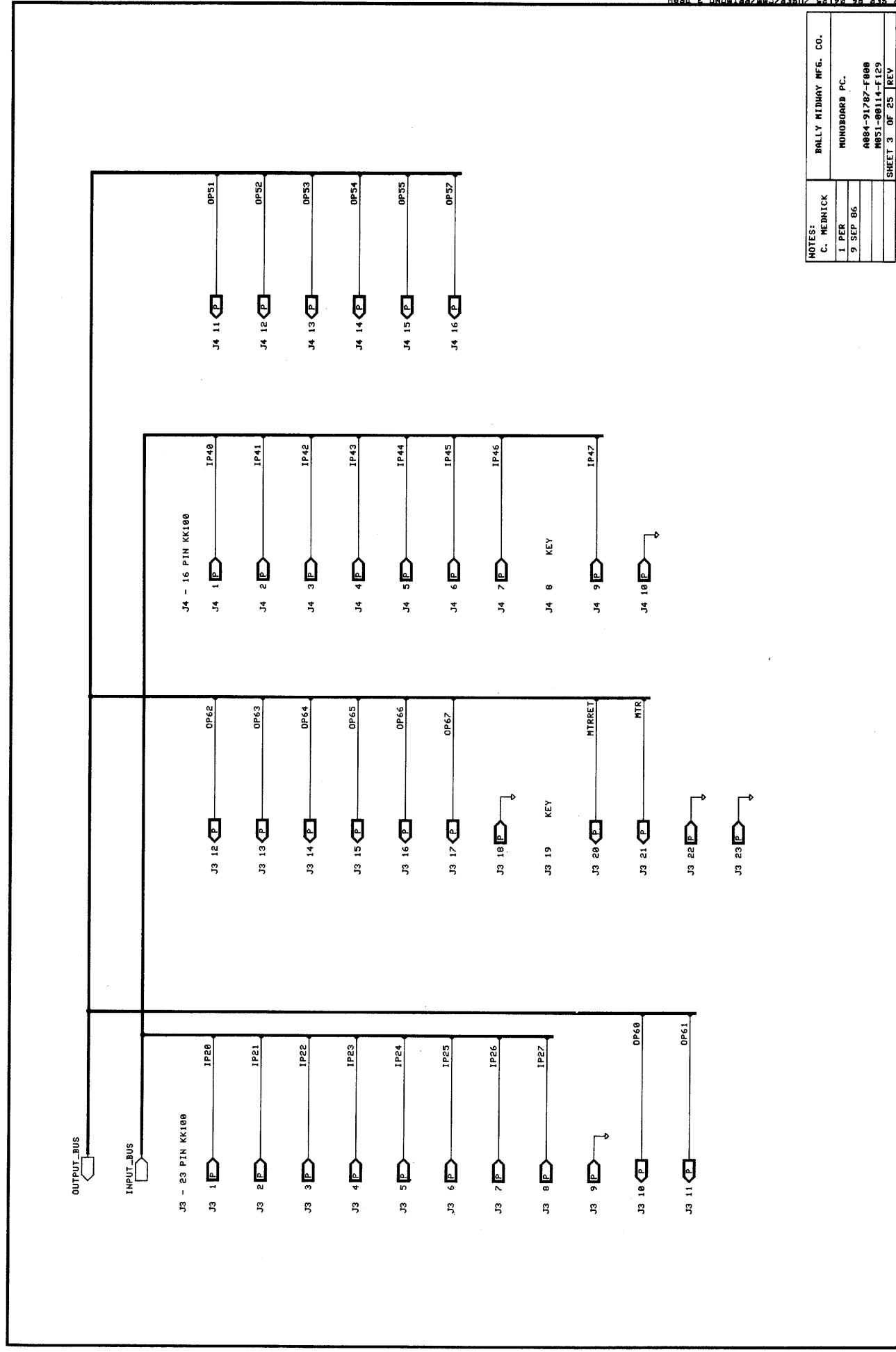

NOTES:	BALLY MIDWAY MFG. CO.
C. MEDNICK	MONOBOARD PC.
1 PER	0884-91787-F000
9 SEP 86	M851-80114-F129
	SHEET 3 OF 25 REV

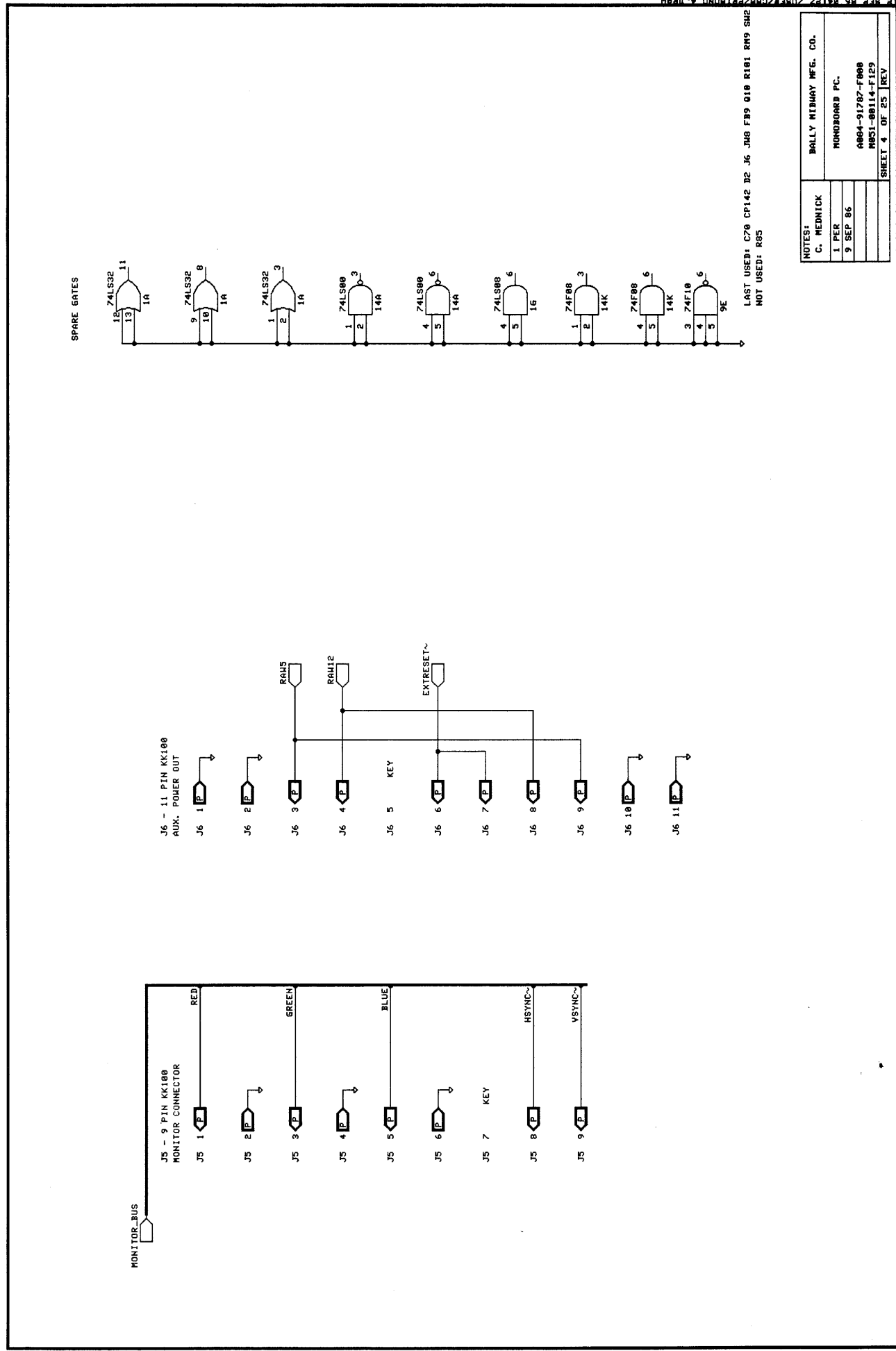

NOTES:	BALLY MIDWAY MFG. CO.
C. MEDNICK	MONOBOARD PC.
1 PER	0884-91787-F000
9 SEP 86	M851-80114-F129
	SHEET 4 OF 25 REV

LAST USED: C70 CP142 D2 J6 J48 F89 G10 R101 RM9 SH2  
 NOT USED: R85

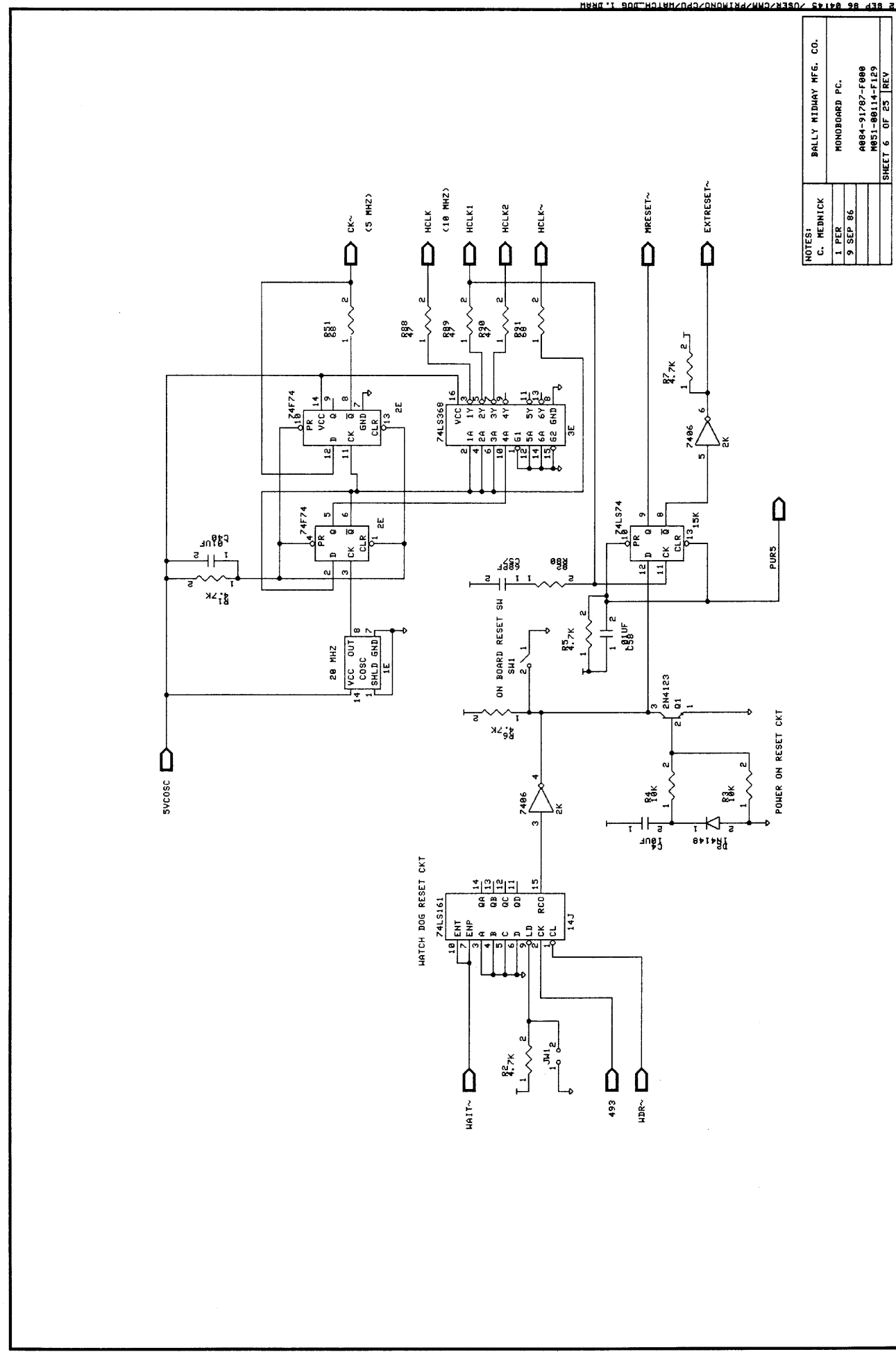
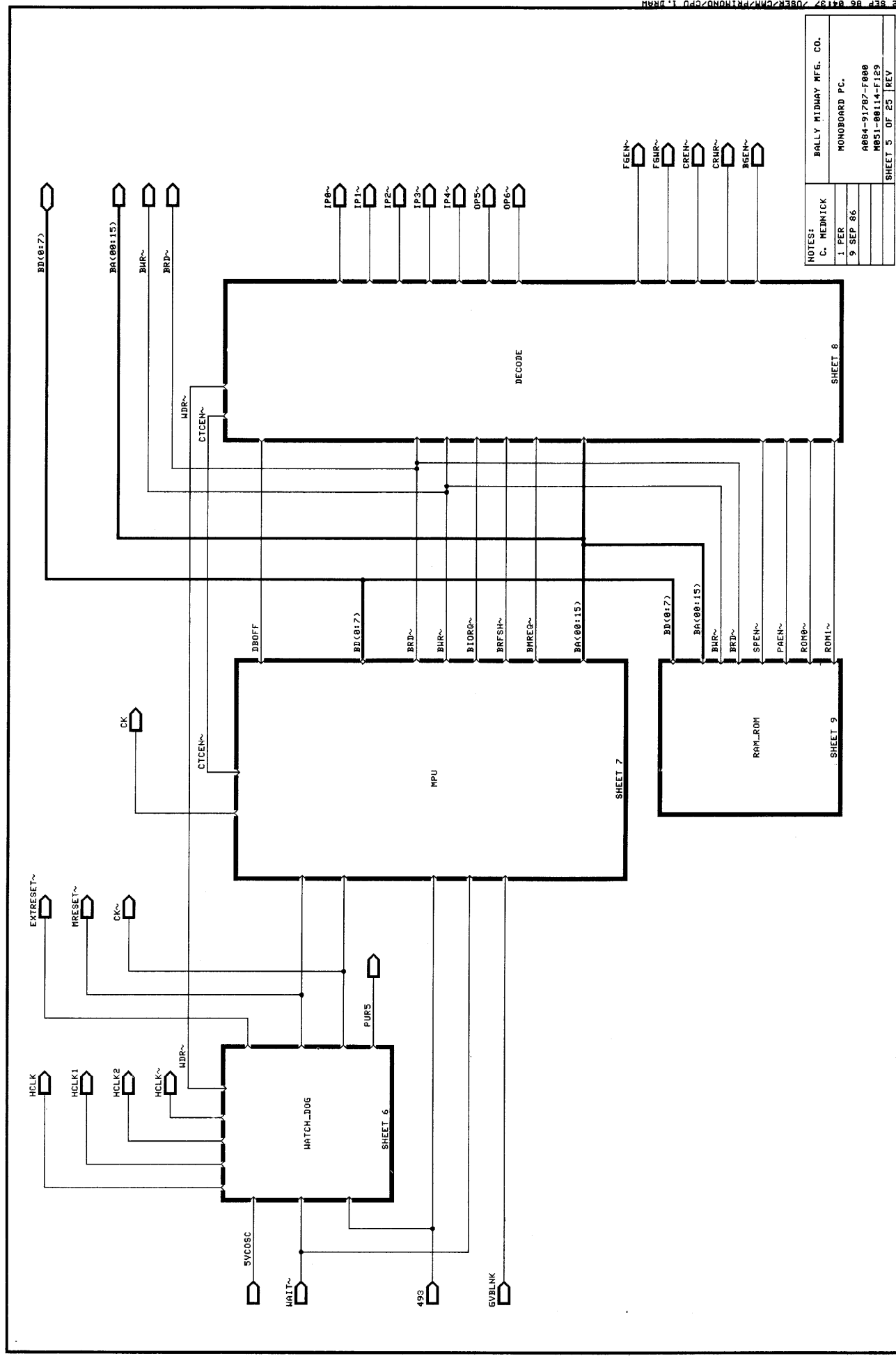



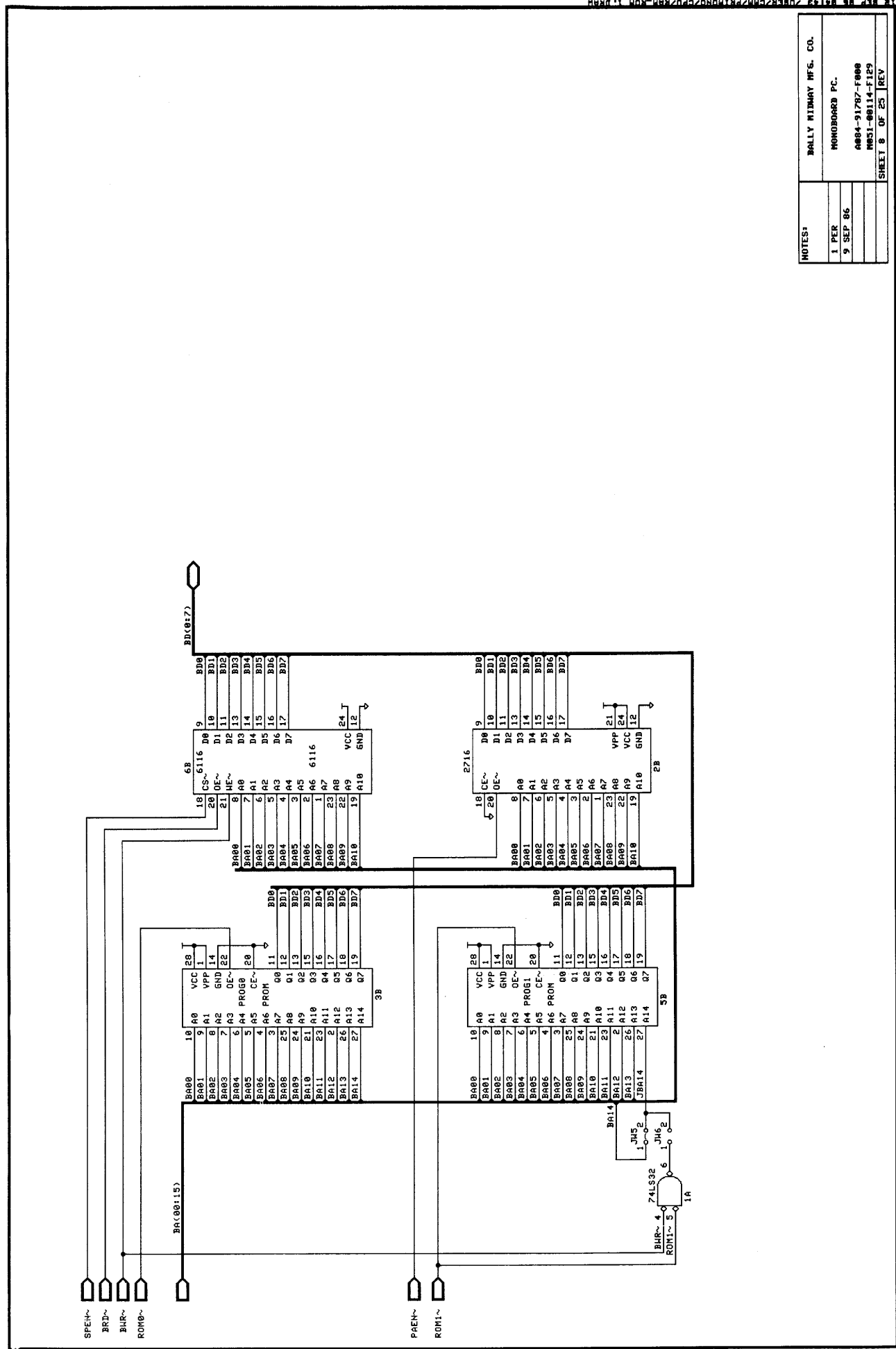
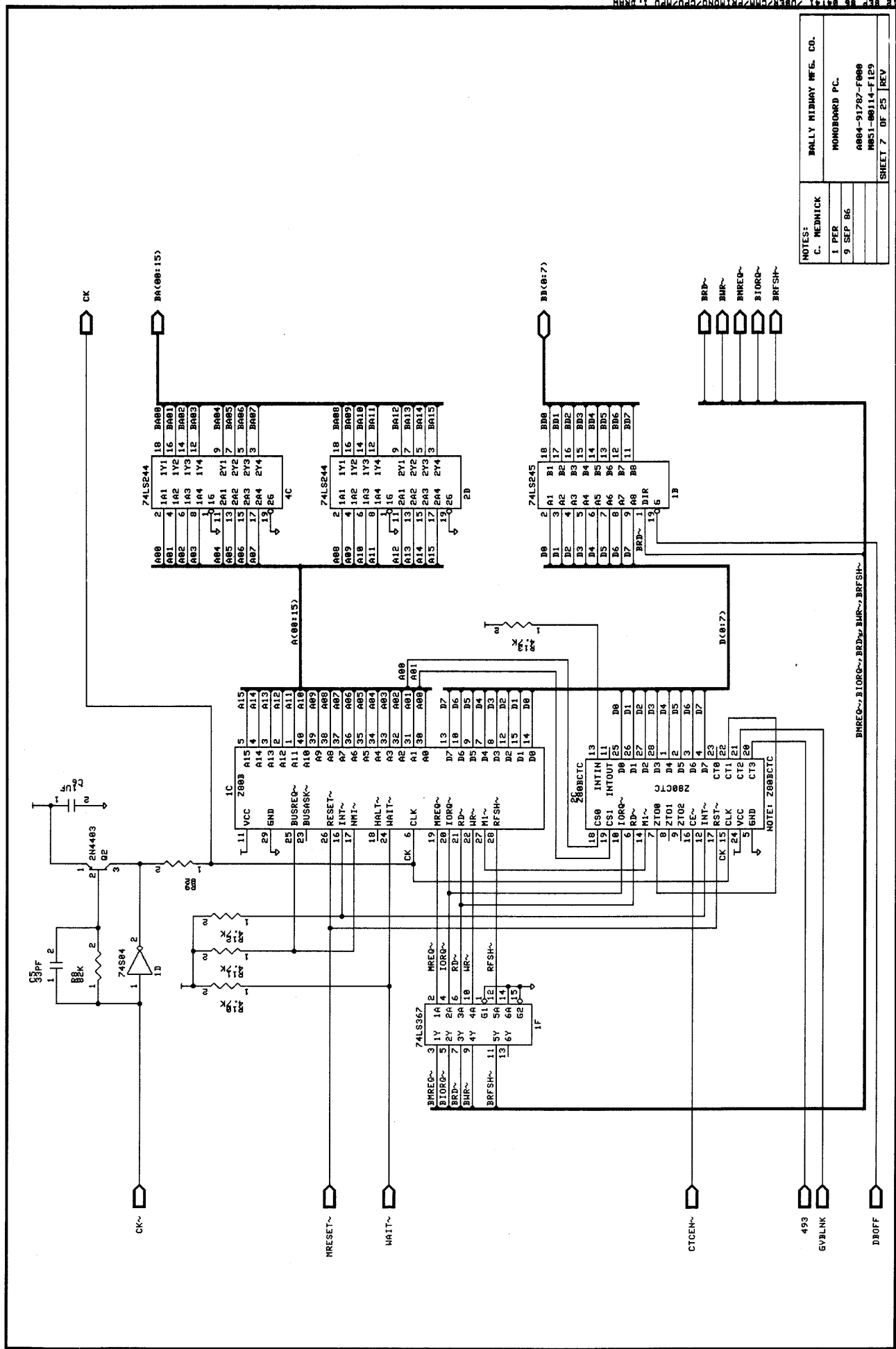

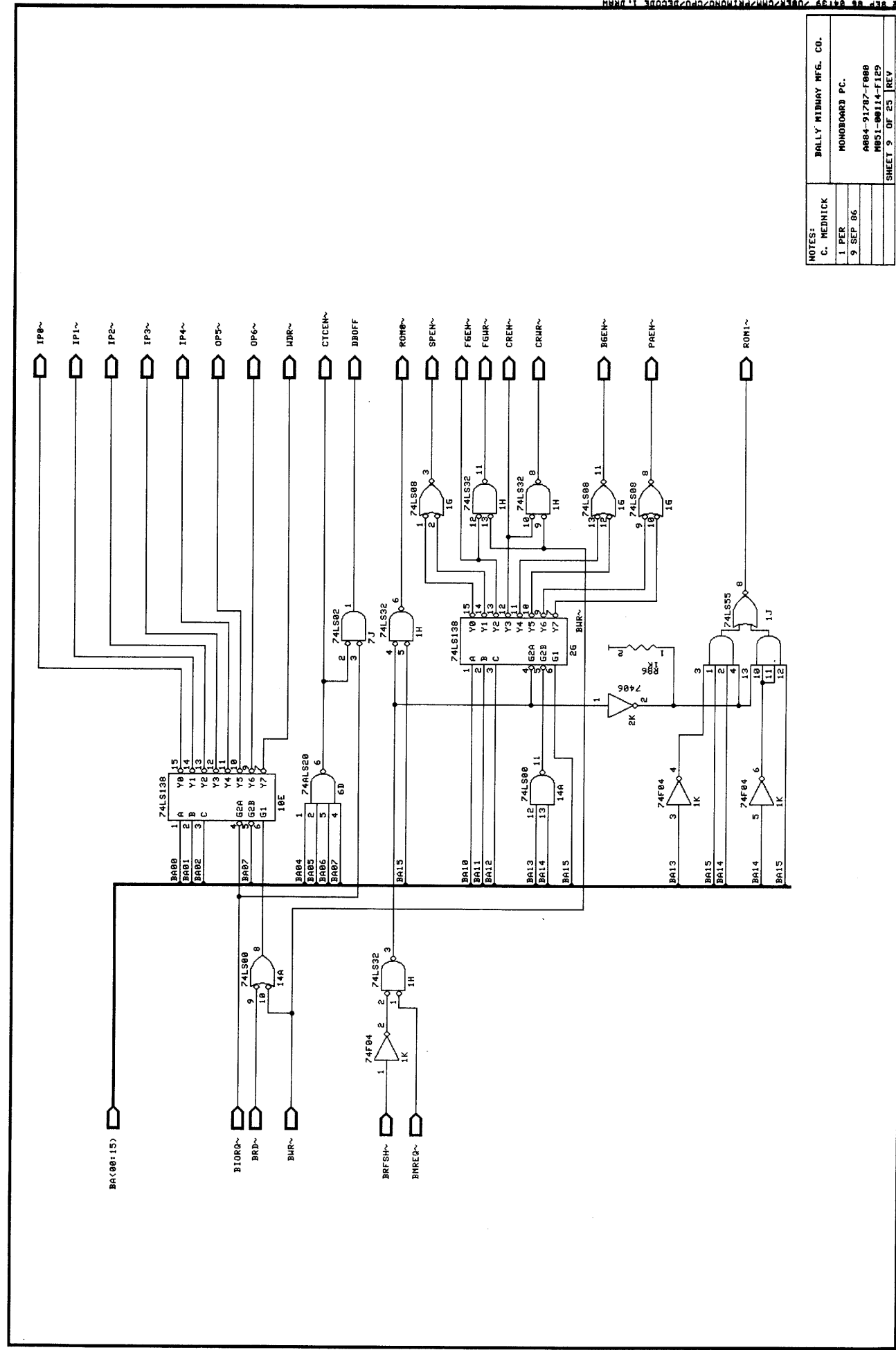

NOTES:  
 C. MEDNICK  
 1 PER  
 9 SEP 86

BALLY MIDWAY MFG. CO.  
 MONOBOARD PC.  
 A884-91787-F888  
 M851-88114-F129  
 SHEET 9 OF 25 REV

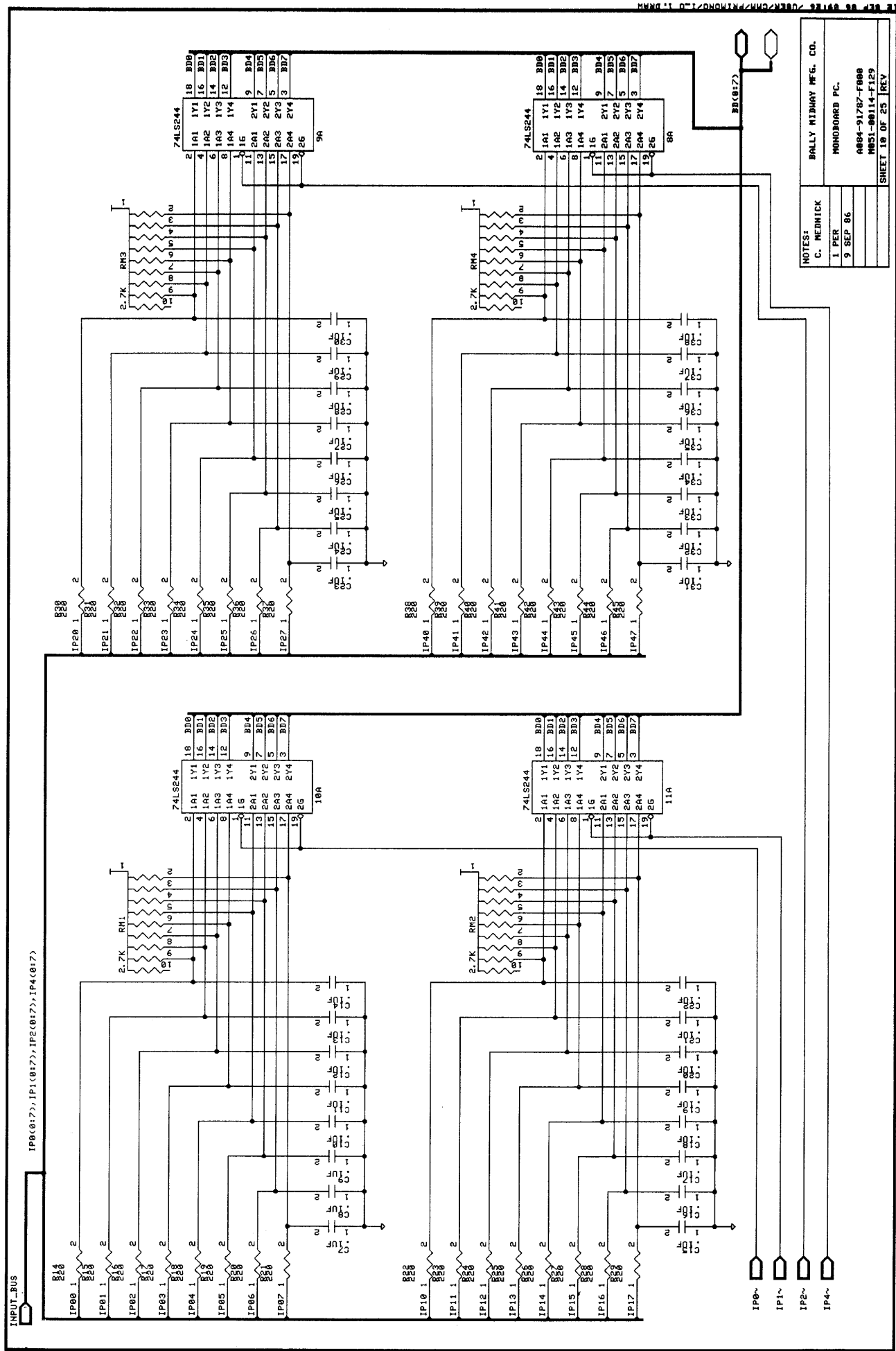

NOTES:  
 C. MEDNICK  
 1 PER  
 9 SEP 86

BALLY MIDWAY MFG. CO.  
 MONOBOARD PC.  
 A884-91787-F888  
 M851-88114-F129  
 SHEET 18 OF 25 REV

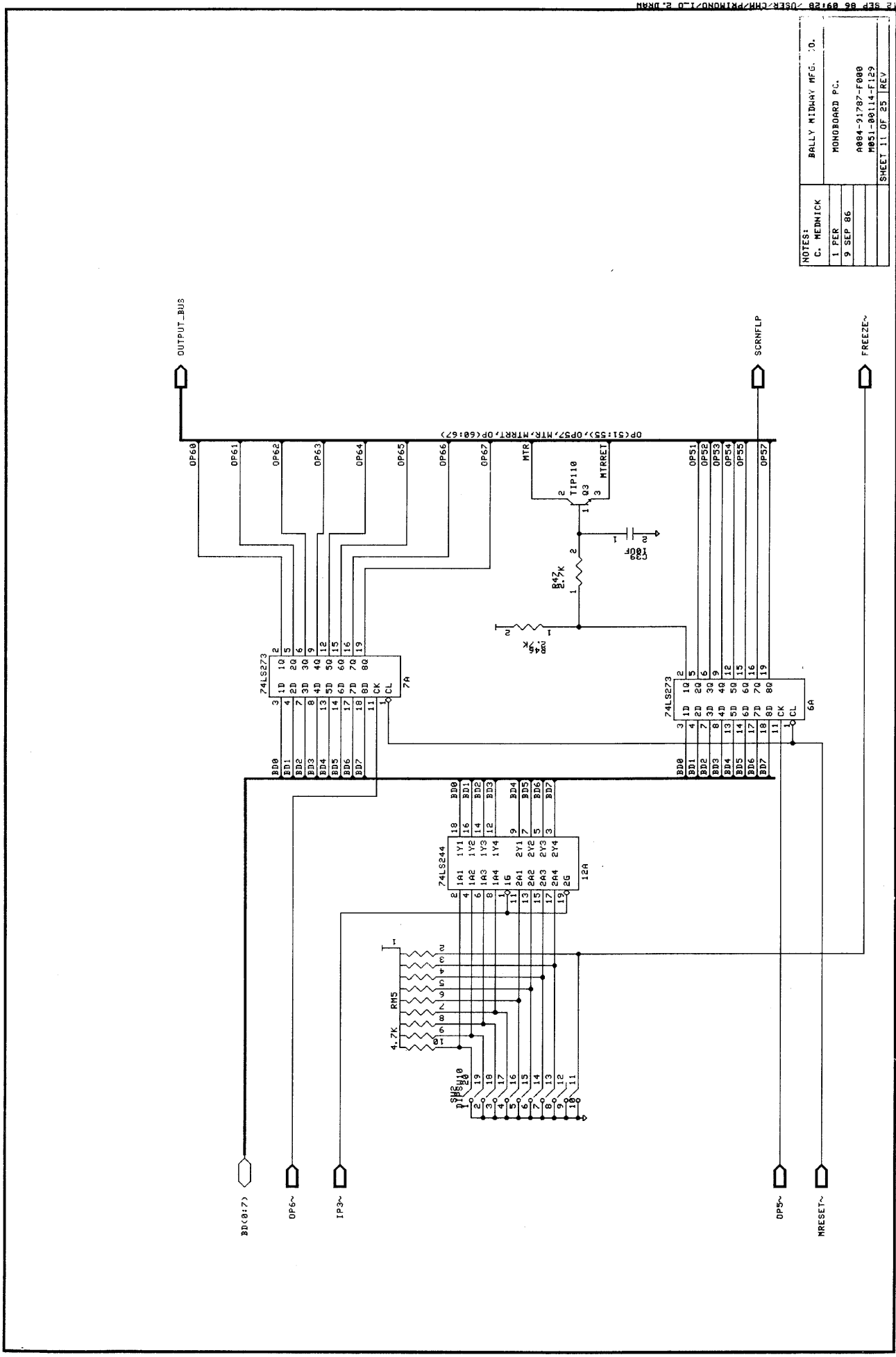

NOTES:  
 C. MEDNICK  
 1 PER  
 9 SEP 86  
 BALLY MIDWAY MFG. CO.  
 MONOBOARD PC.  
 A884-91787-F088  
 M851-88114-F129  
 SHEET 11 OF 25 REV

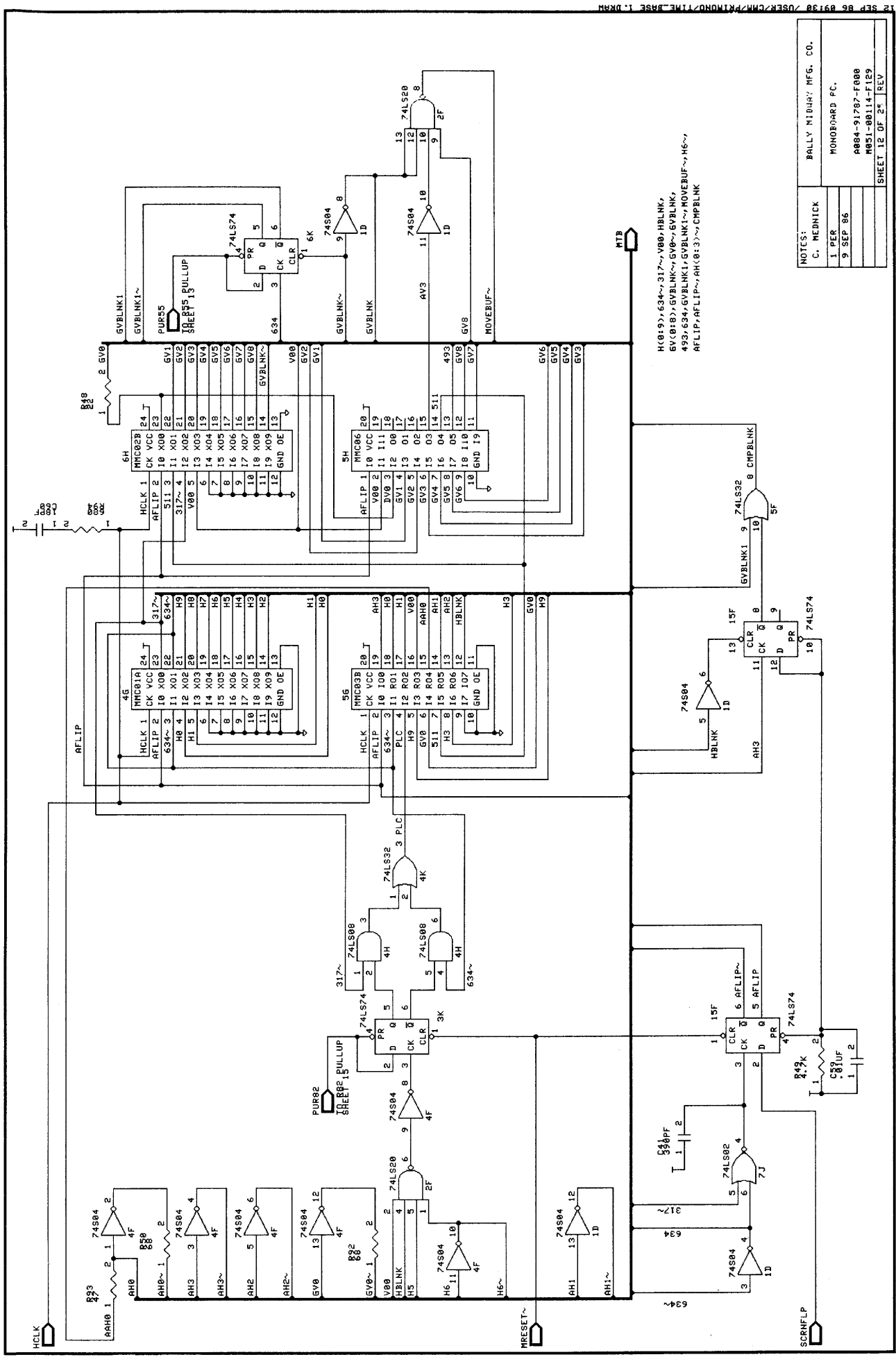

NOTES:  
 C. MEDNICK  
 1 PER  
 9 SEP 86  
 BALLY MIDWAY MFG. CO.  
 MONOBOARD PC.  
 A884-91787-F088  
 M851-88114-F129  
 SHEET 12 OF 25 REV

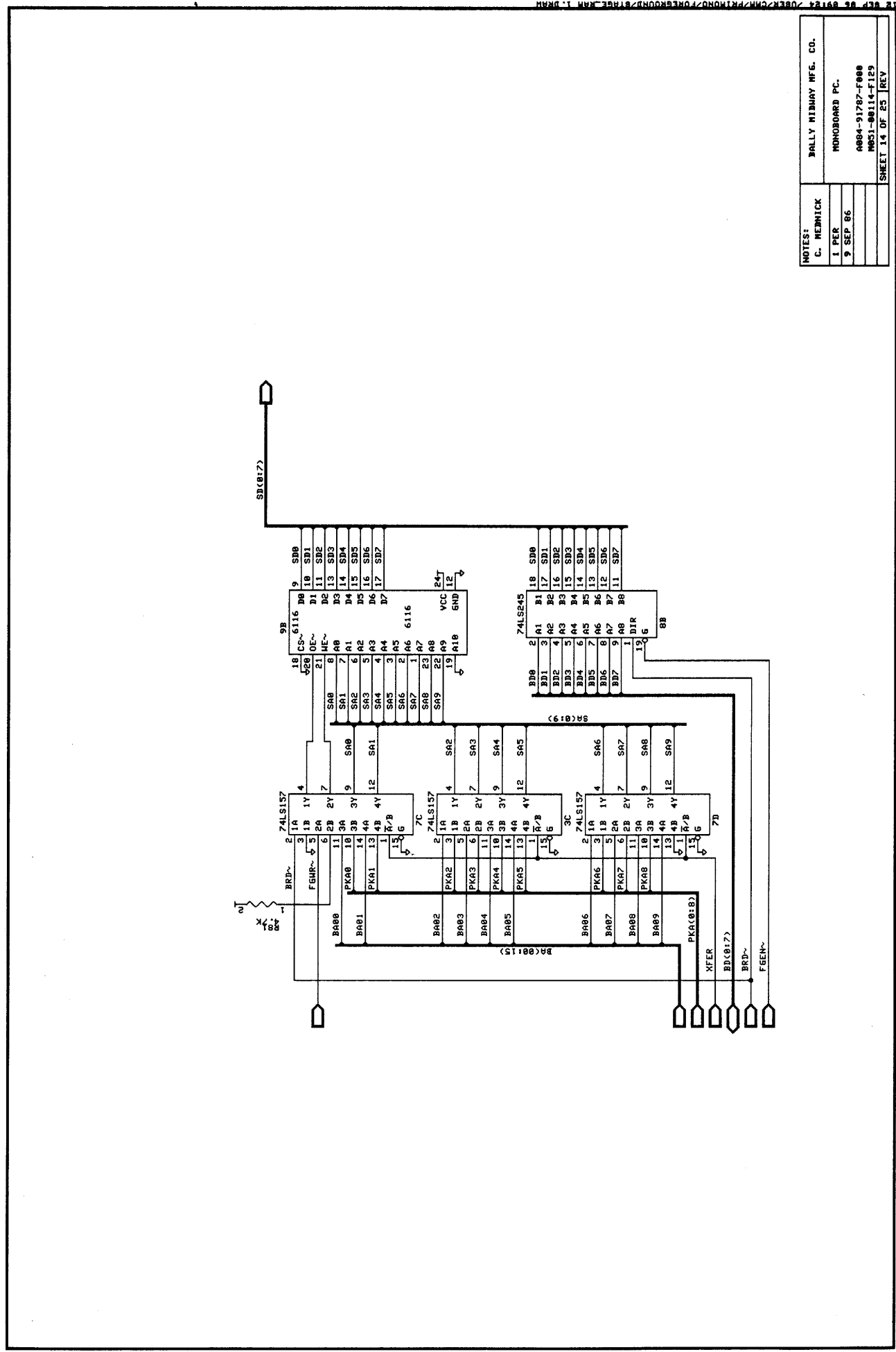
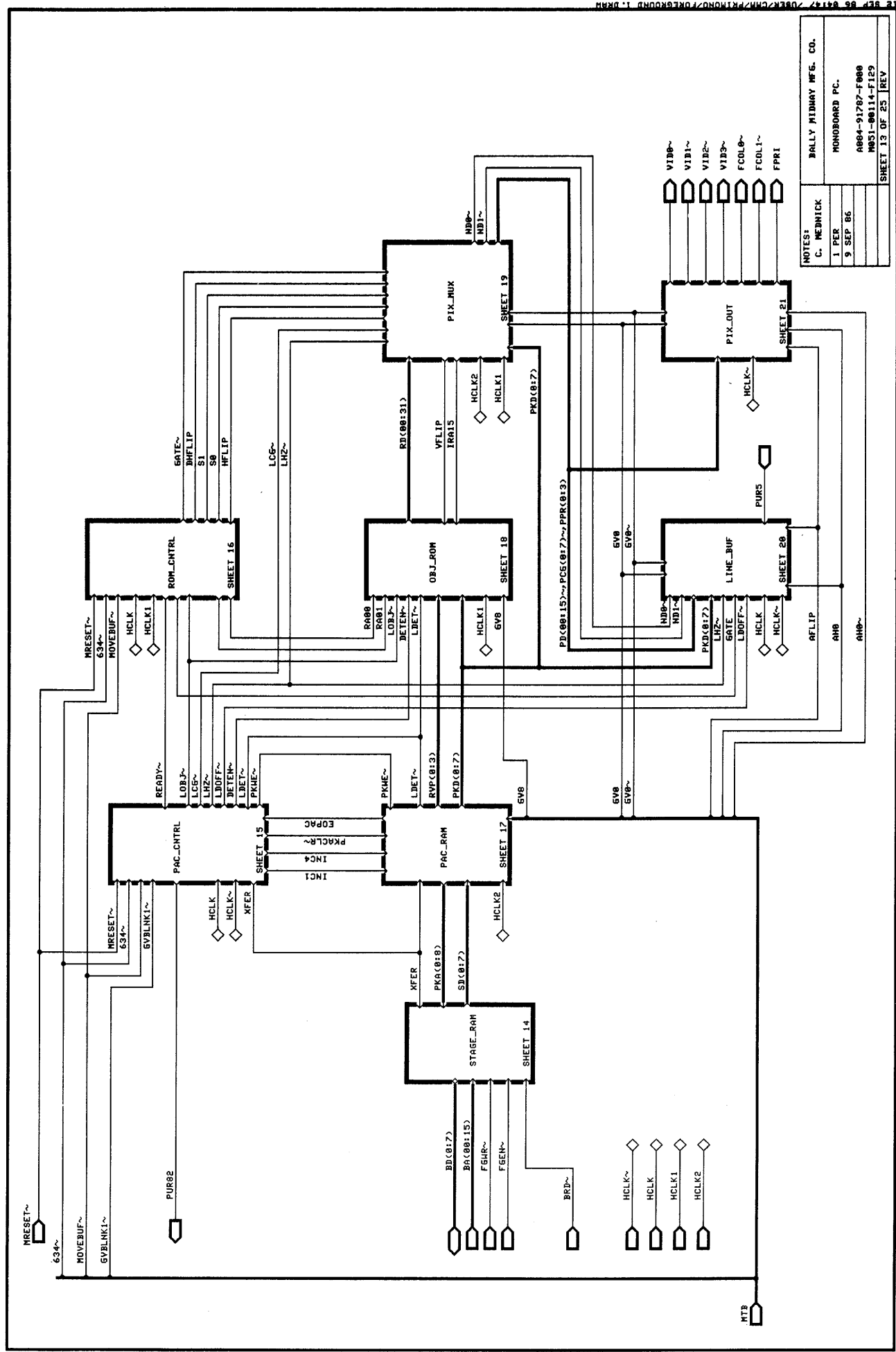

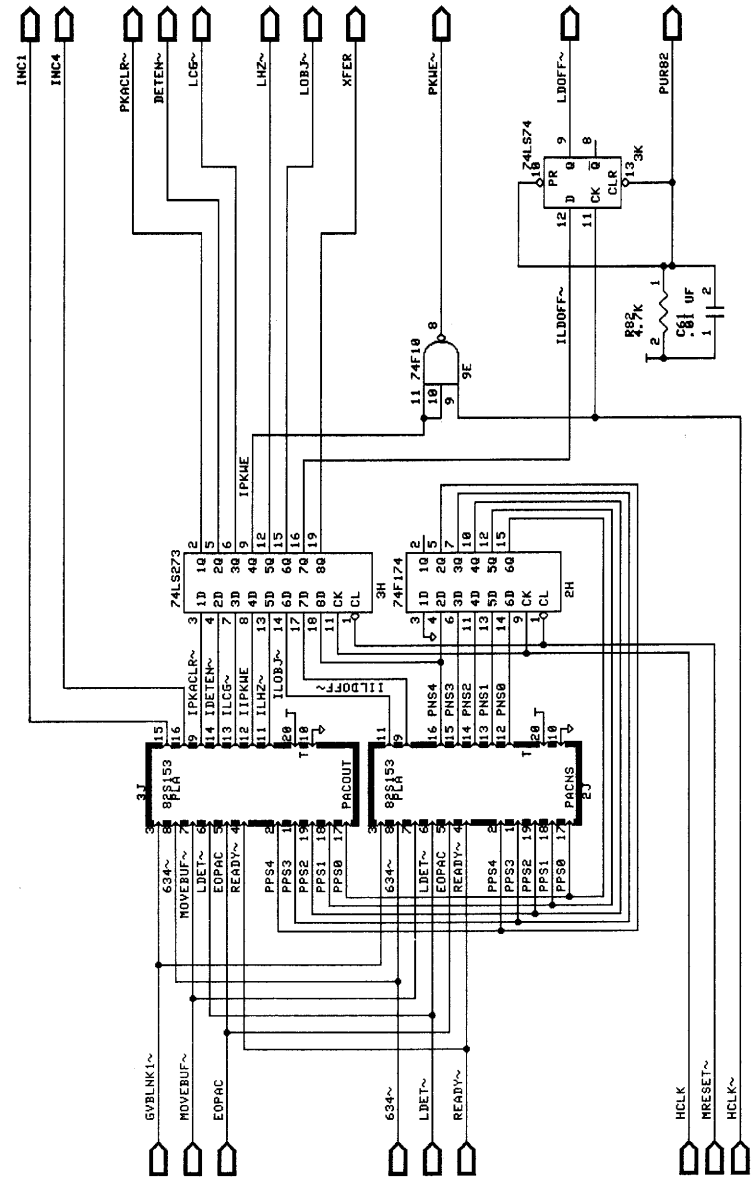

NOTES:  
 C. REDNICK  
 1 PER  
 9 SEP 86  
 BALLY MIDWAY MFG. CO.  
 MONITORBOARD PC.  
 0884-91787-F808  
 M851-88114-F129  
 SHEET 15 OF 25 REV

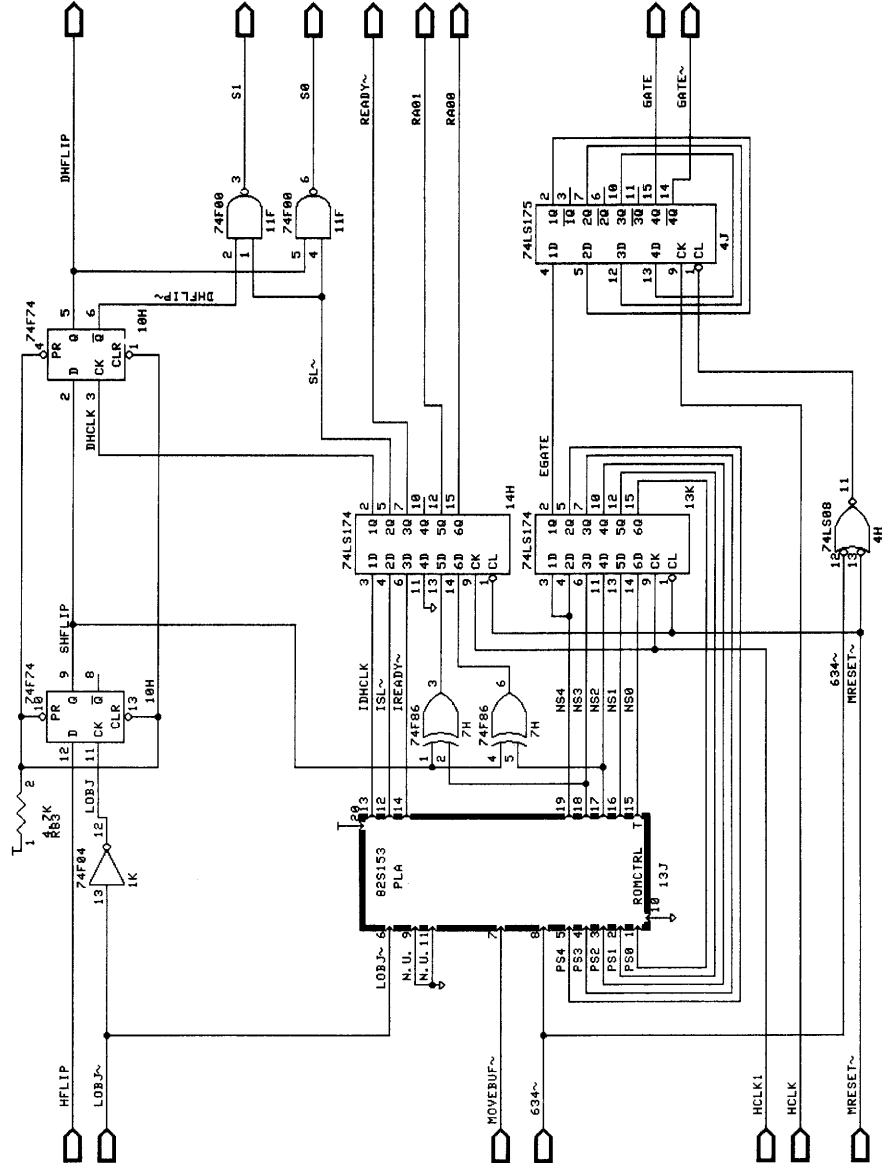

NOTES:  
 C. REDNICK  
 1 PER  
 9 SEP 86  
 BALLY MIDWAY MFG. CO.  
 MONITORBOARD PC.  
 0884-91787-F808  
 M851-88114-F129  
 SHEET 16 OF 25 REV

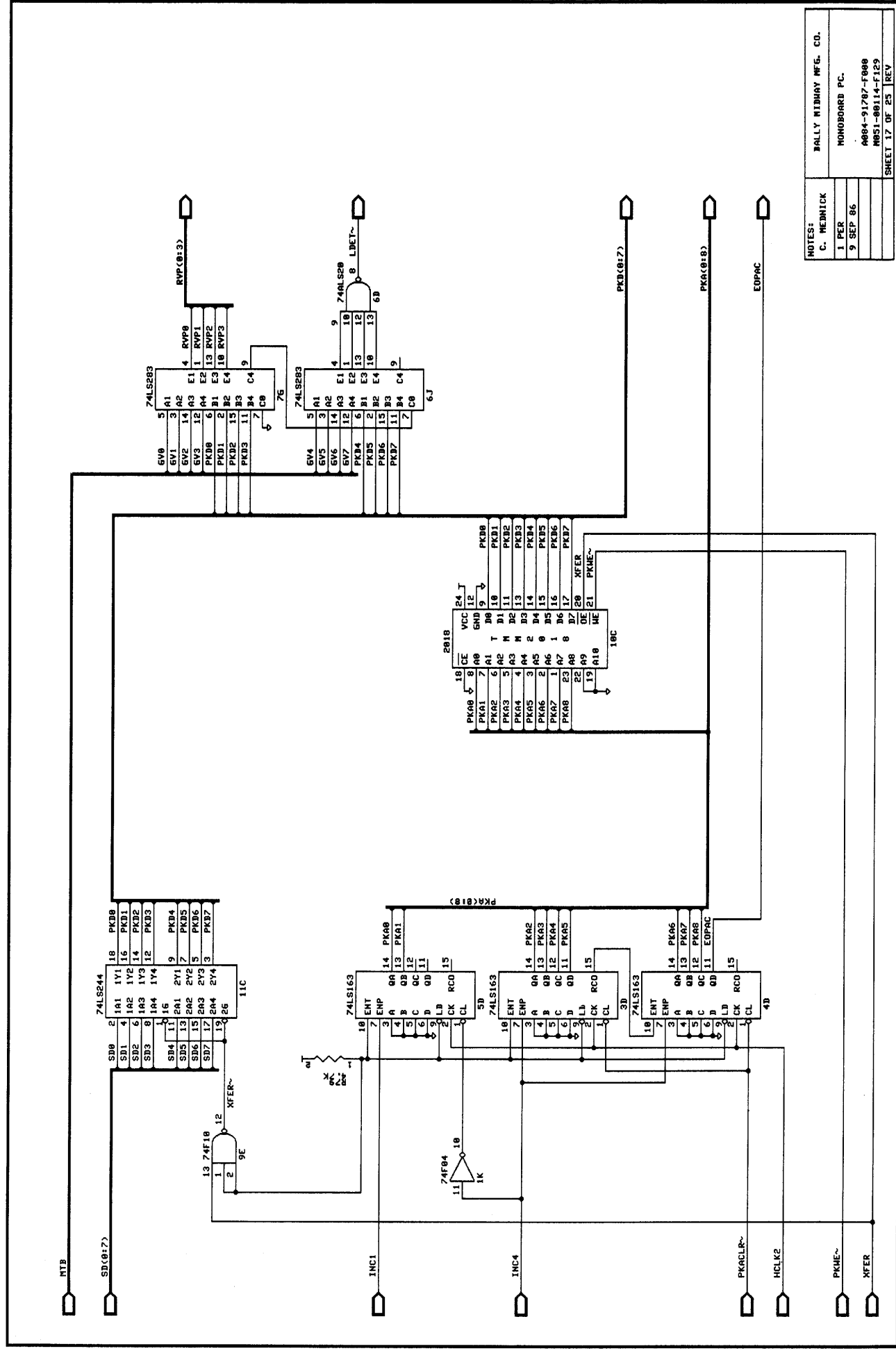

NOTES:  
 C. MEDNICK  
 1 PER  
 9 SEP 86  
 MONOBOARD PC.  
 A884-91787-F888  
 M851-88114-F129  
 SHEET 17 OF 25 REV

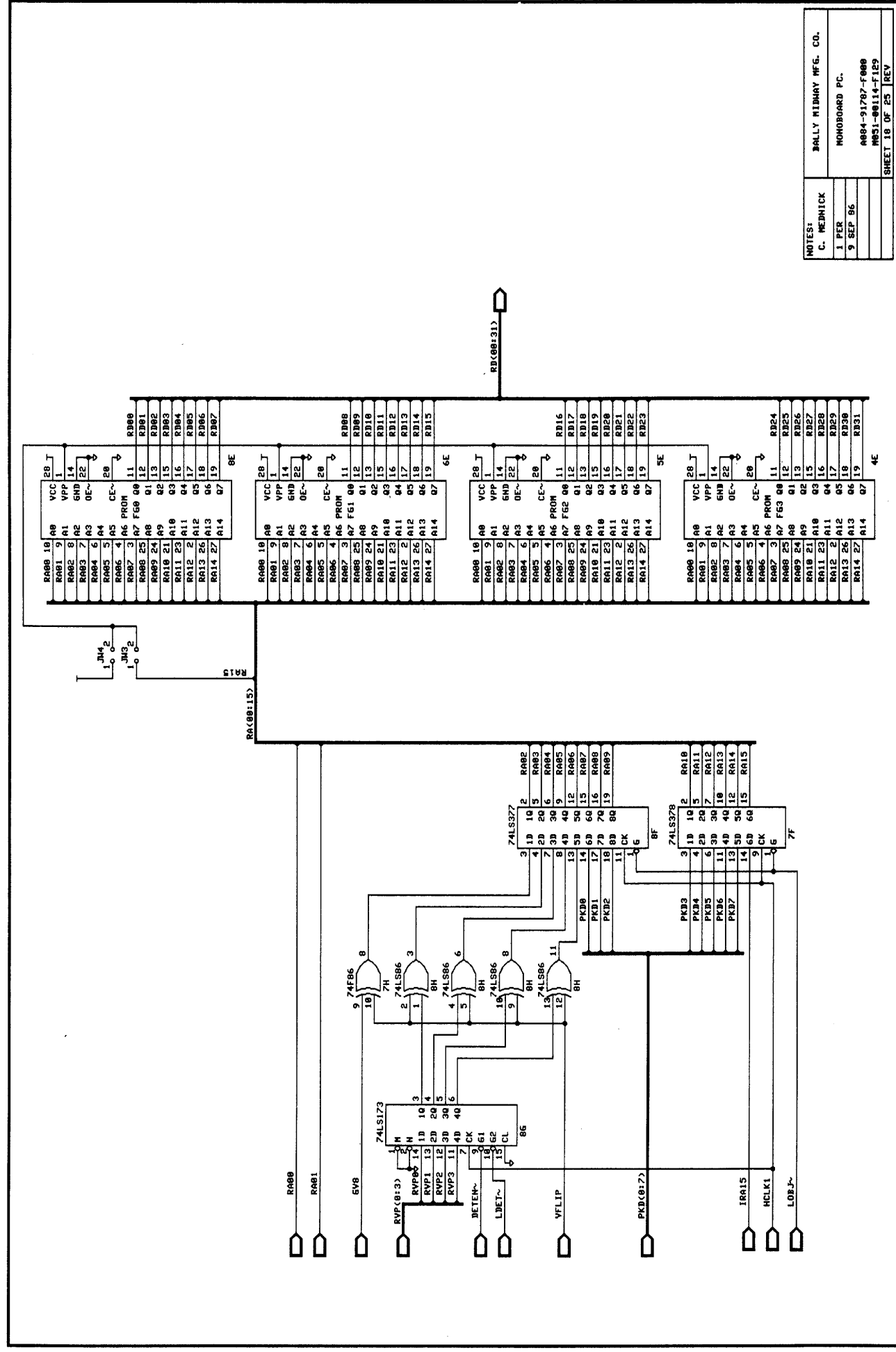

NOTES:  
 C. MEDNICK  
 1 PER  
 9 SEP 86  
 MONOBOARD PC.  
 A884-91787-F888  
 M851-88114-F129  
 SHEET 18 OF 25 REV

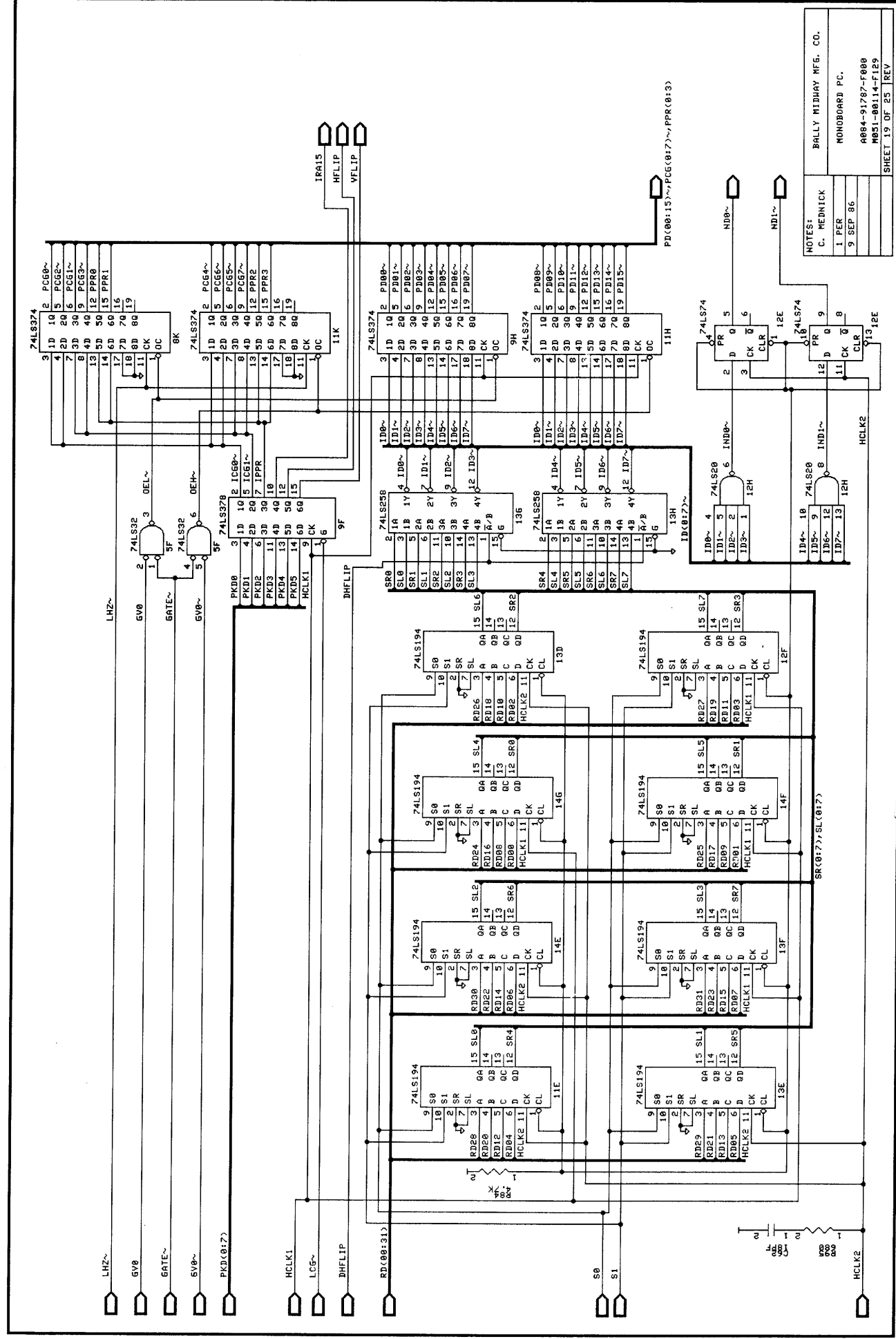

NOTES:  
 C. MEDNICK  
 1 PER  
 9 SEP 86  
 MONOBOARD PC.  
 A864-91787-F088  
 M051-88114-F129  
 SHEET 19 OF 25 REV

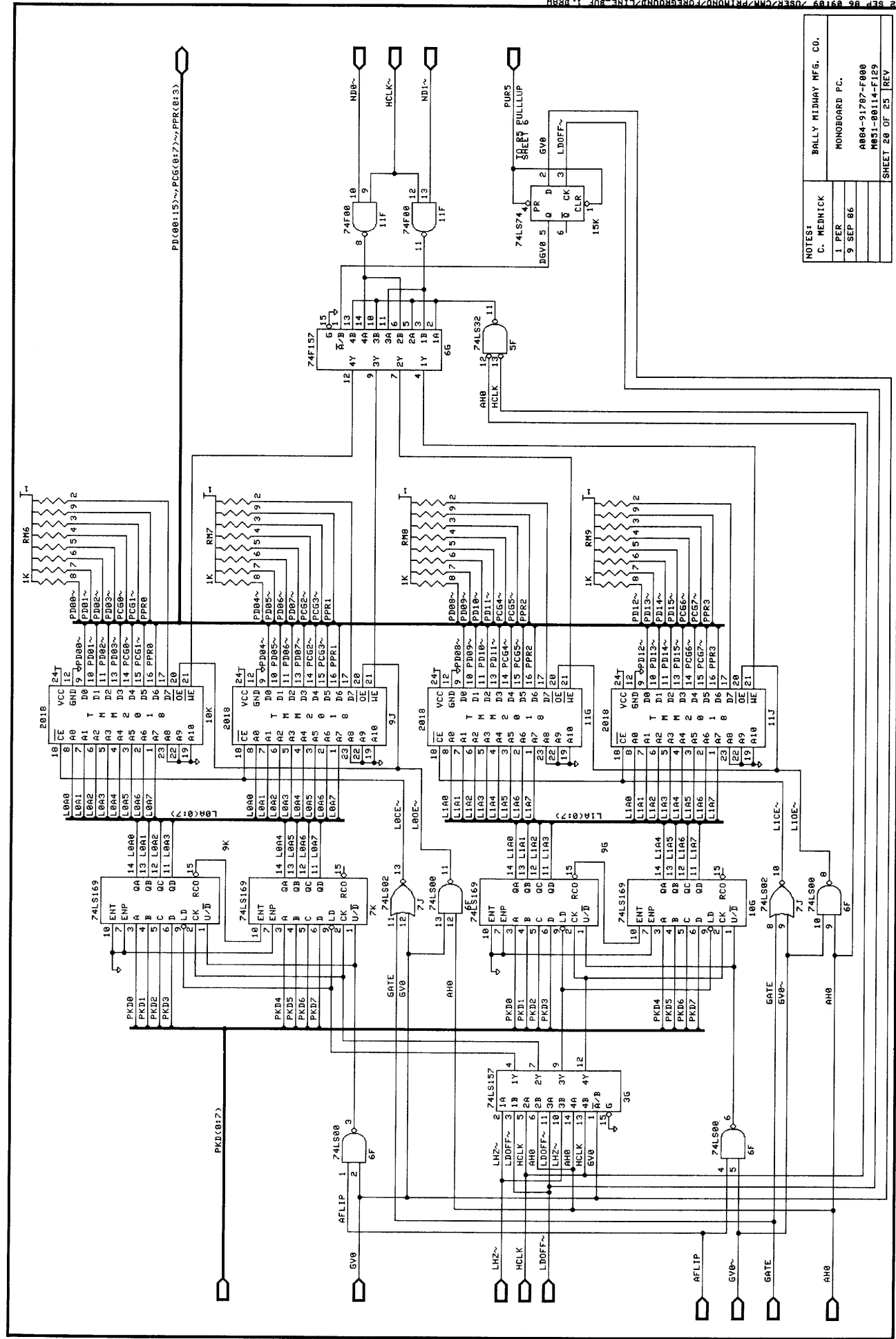

NOTES:  
 C. MEDNICK  
 1 PER  
 9 SEP 86  
 MONOBOARD PC.  
 A864-91787-F088  
 M051-88114-F129  
 SHEET 20 OF 25 REV

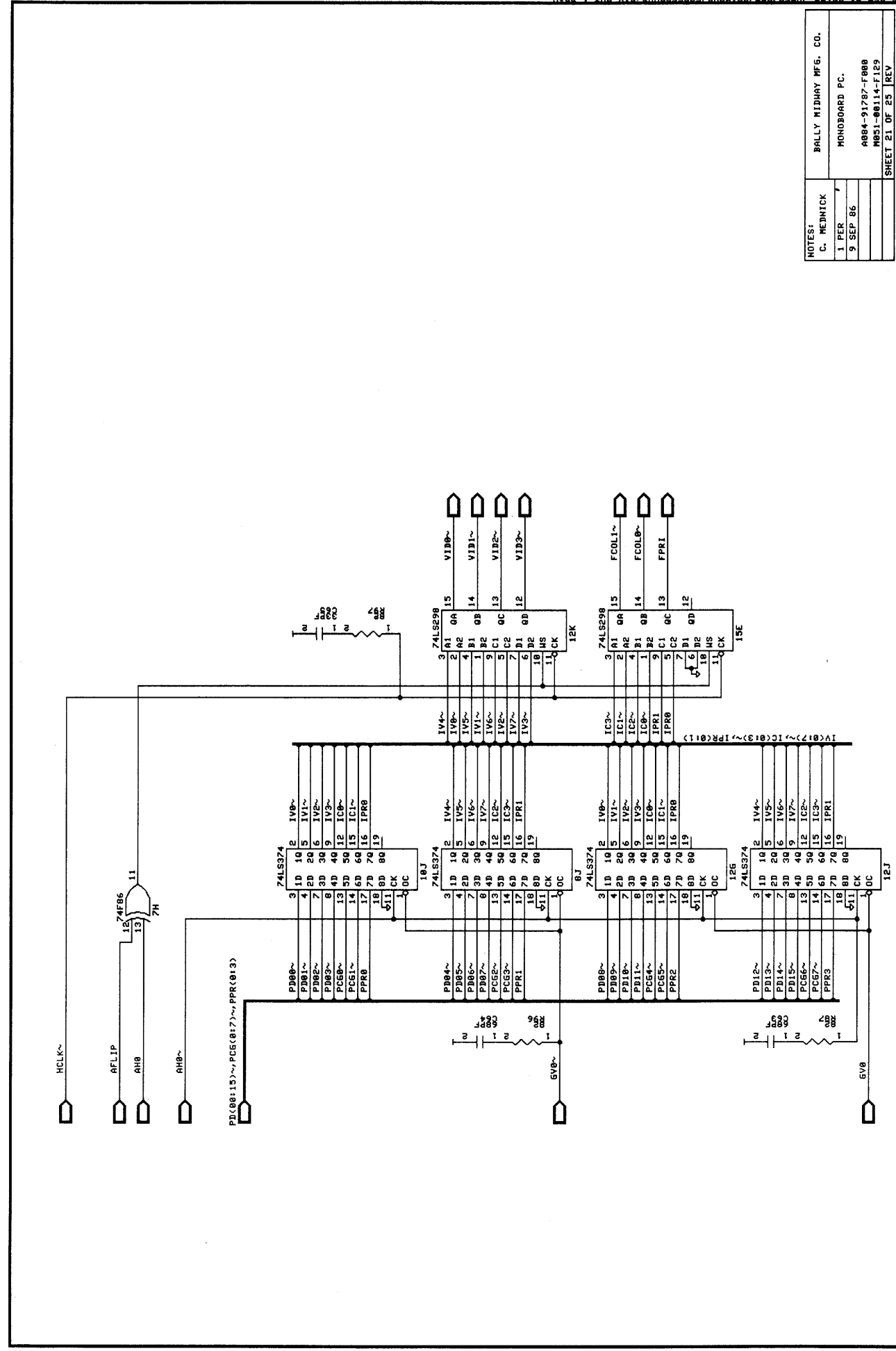

NOTES:  
 C. MEDNICK  
 1 PER  
 9 SEP 86  
 MONDBOARD PC.  
 AB84-91787-F888  
 M851-08114-F129  
 SHEET 21 OF 25 REV

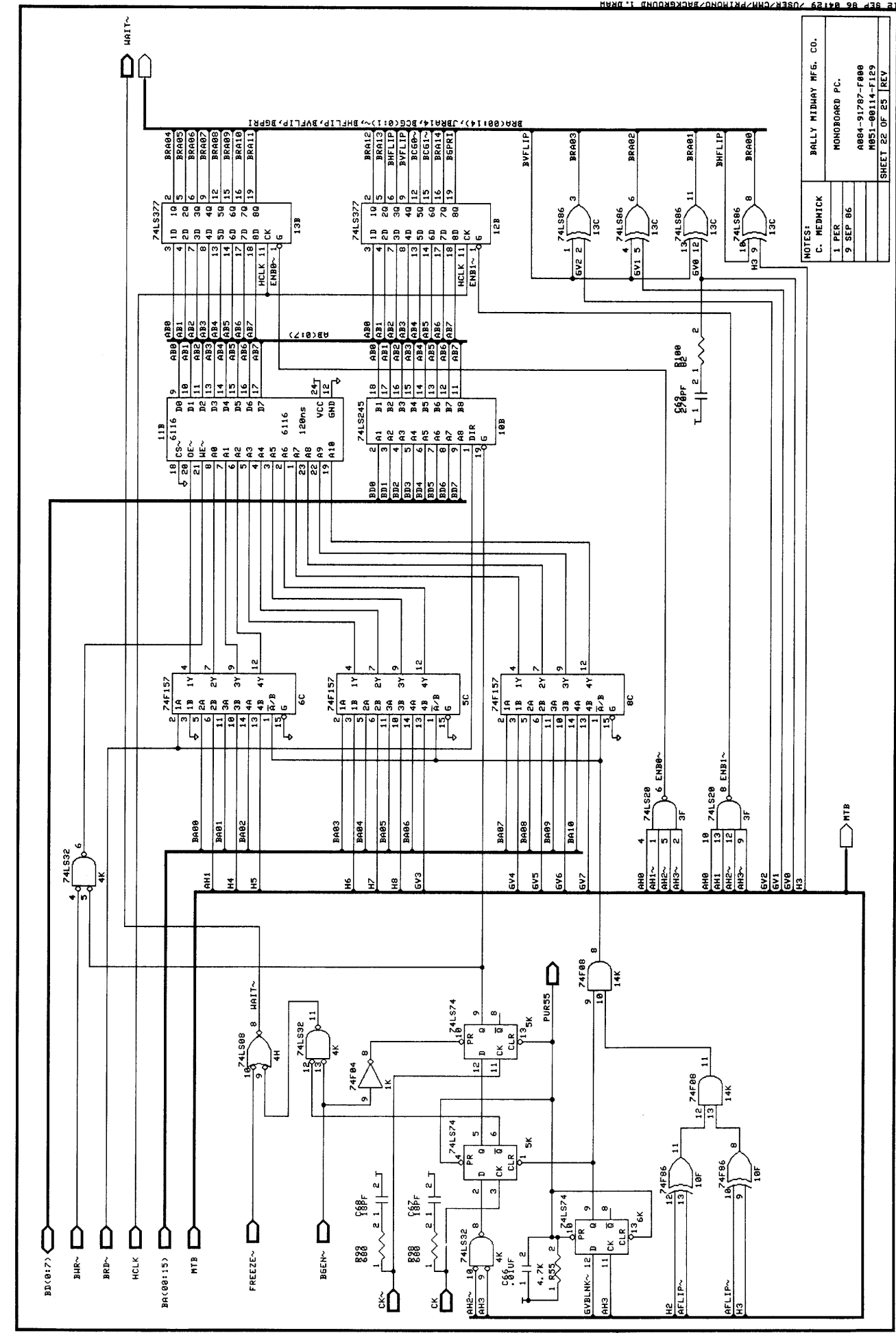

NOTES:  
 C. MEDNICK  
 1 PER  
 9 SEP 86  
 MONDBOARD PC.  
 AB84-91787-F888  
 M851-08114-F129  
 SHEET 22 OF 25 REV

12 SEP 86 09:28 /08K/CNH/PRMOND/FOREGROUND/P1X.DOT 1.DRAW

12 SEP 86 04:19 /08K/CNH/PRMOND/BACKGROUND 1.DRAW



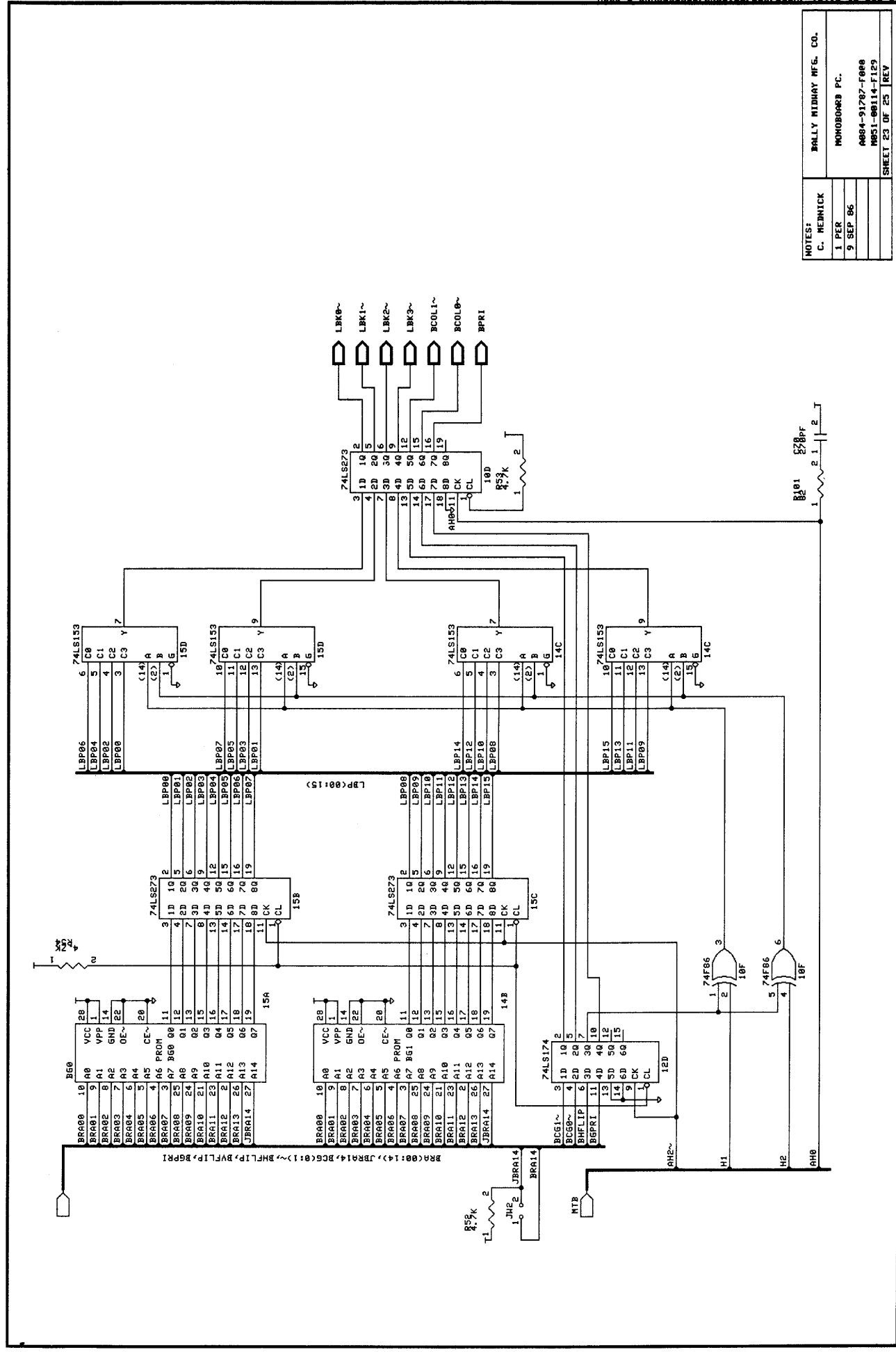

NOTES:  
 C. WEINICK  
 1 PER  
 9 SEP 86

BALLY MIDWAY MFG. CO.  
 MONOBOARD PC.  
 A884-91787-F088  
 M851-88114-F129  
 SHEET 23 OF 25 REV

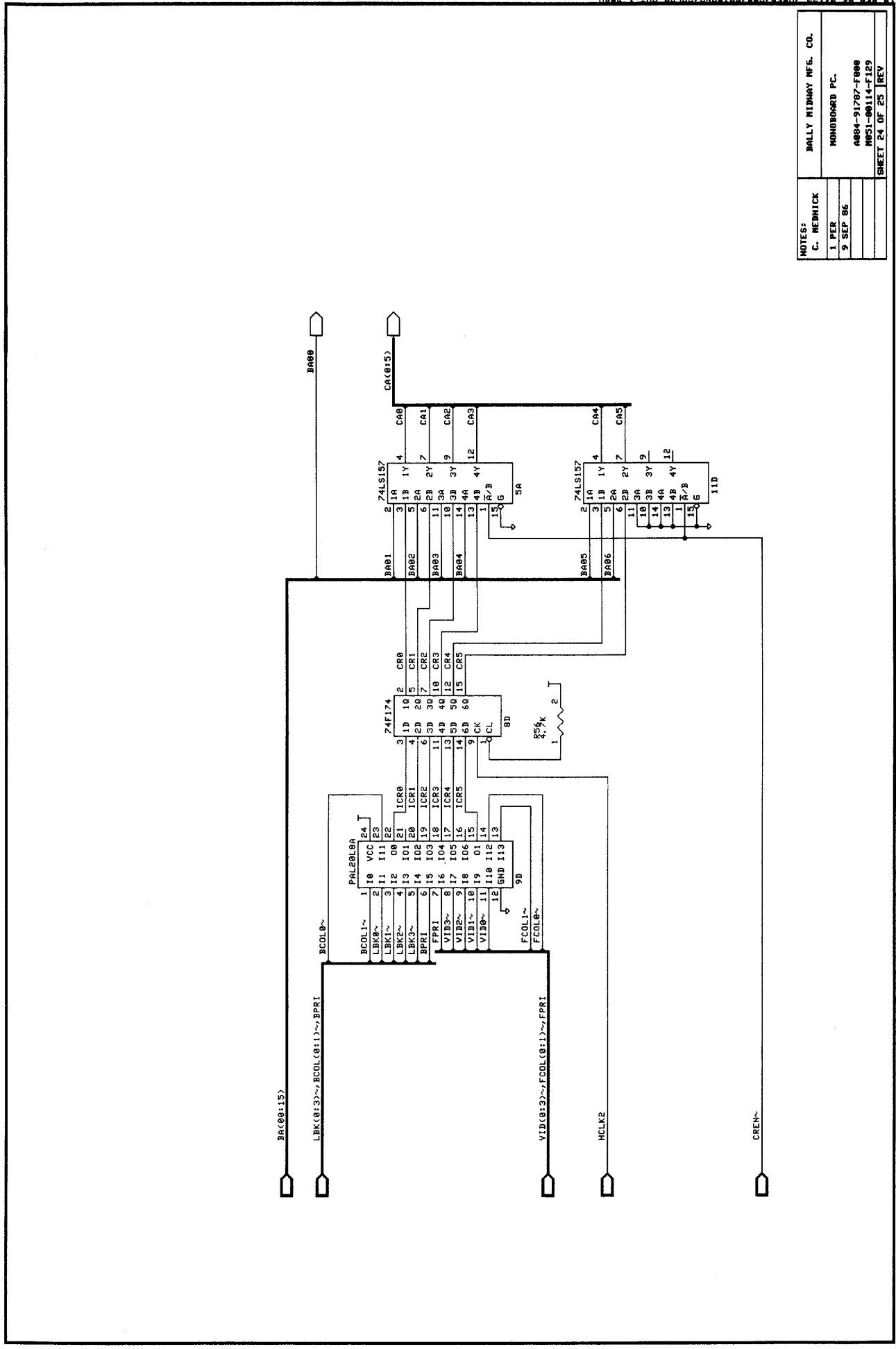

NOTES:  
 C. WEINICK  
 1 PER  
 9 SEP 86

BALLY MIDWAY MFG. CO.  
 MONOBOARD PC.  
 A884-91787-F088  
 M851-88114-F129  
 SHEET 24 OF 25 REV

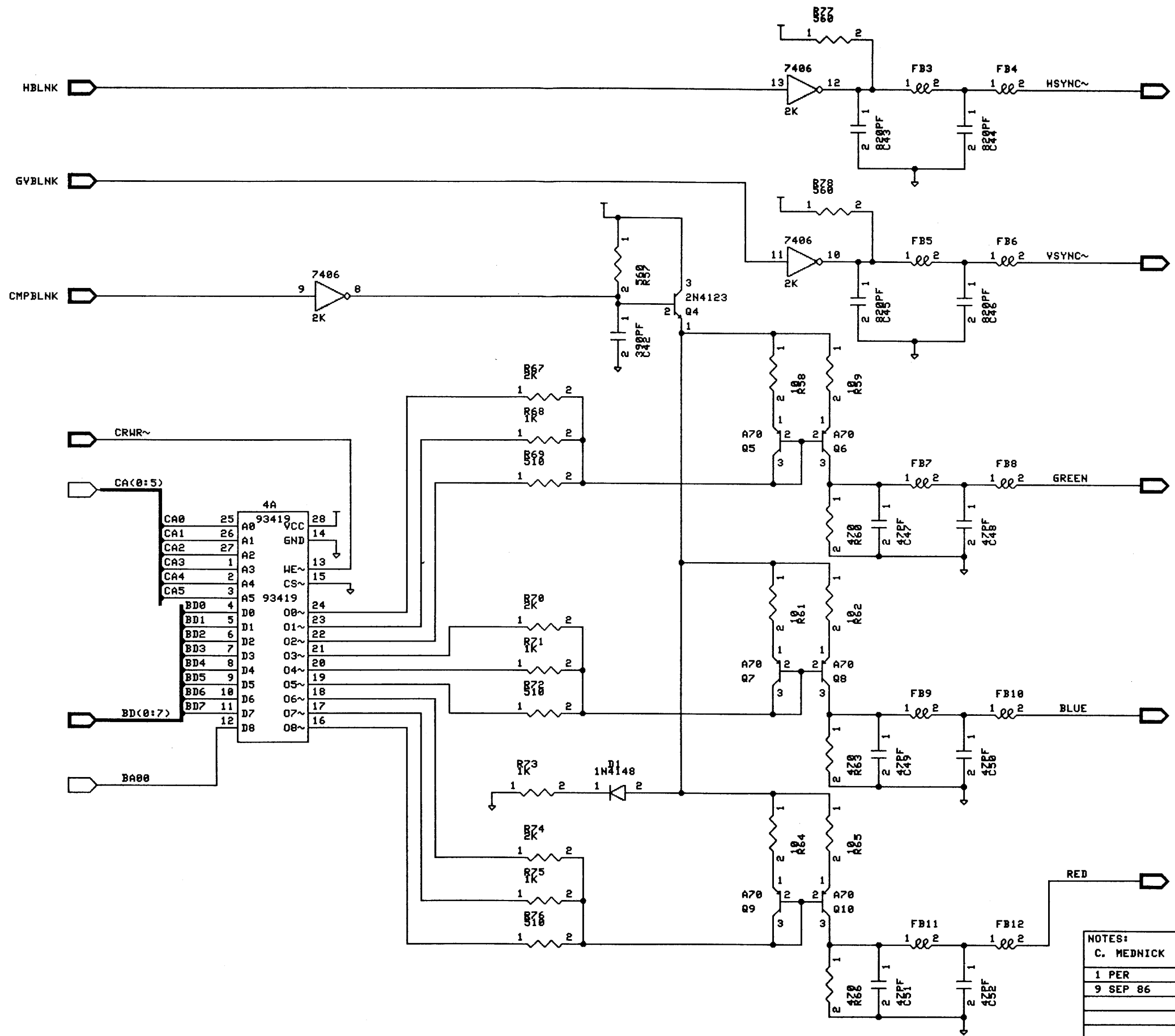

4A		93419	
CA0	25	A0	VCC
CA1	26	A1	GND
CA2	27	A2	
CA3	1	A3	WE~
CA4	2	A4	CS~
CA5	3	A5	93419
BD0	4	D0	00~
BD1	5	D1	01~
BD2	6	D2	02~
BD3	7	D3	03~
BD4	8	D4	04~
BD5	9	D5	05~
BD6	10	D6	06~
BD7	11	D7	07~
BD8	12	D8	08~

NOTES:	BALLY MIDWAY MFG. CO.
C. MEDNICK	MONOBOARD PC.
1 PER	A004-91787-F000
9 SEP 86	M051-00114-F129
	SHEET 25 OF 25 REV

12 SEP 86 04:35 7USER/CMM/PR1MONO/COLOR.DOT 2:JRM

SOUNDS GOOD  
 A084-91863-B000  
 M051-00114-B150

DESIGNATION LIST

DESIGNATION	DESCRIPTION
CP1-CP7,CP9-CP13	.01MF AX CER.
CP14,CP15	10MF AX TANT.
CP16	100MF AX ELECT.
CP101,CP102	0.1UF AX CER.
C1,C2	390PF AX CER.
C3-C5	100PF AX CER.
C6,C7	820PF AX CER.
C8-C11	100PF AX CER.
C101,C102	390PF AX CER.
C103	1MF RD TANT.
C104	.01MF AX CER.
C105	47MF AX ELECT.
C106	680PF AX CER.
C107	.01MF AX CER.
C108	1MF RD TANT.
C109	68PF AX CER 10%
C110	.01 MF AX CER.
C111	150PF AX CER 10%
C112	470 PF AX CER 10%
C113	270 PF AX CER 10%
C114	1MF RD TANT.
C115	5600PF AX CER 10%
C116	.01MF AX CER.
C117	1MF RD TANT.
C118	270PF AX CER 10%
C119	10MF RD TANT.
C120	.01MF AX CER.
C121	10MF RD TANT.
C122	47MF AX ELECT.
C123	100MF AX ELECT.
C301	150PF AX CER.
C302,C303	470PF AX CER 10%
C304,C307	0.1UF AX CER.
R1-R3	4.7K OHM 1/4W CRBN.
R4	10K OHM 1/4W CRBN.
R5	100K OHM 1/4W CRBN.
R6-R7,R9	4.7K OHM 1/4W CRBN.
R10	1K OHM 1/4W CRBN.
R12-R14	4.7K OHM 1/4W CRBN.
R15,R16	10K OHM 1/4W CRBN.
R17,R18	100 OHM 1/4W CRBN.
R19-R21	10K OHM 1/4W CRBN.

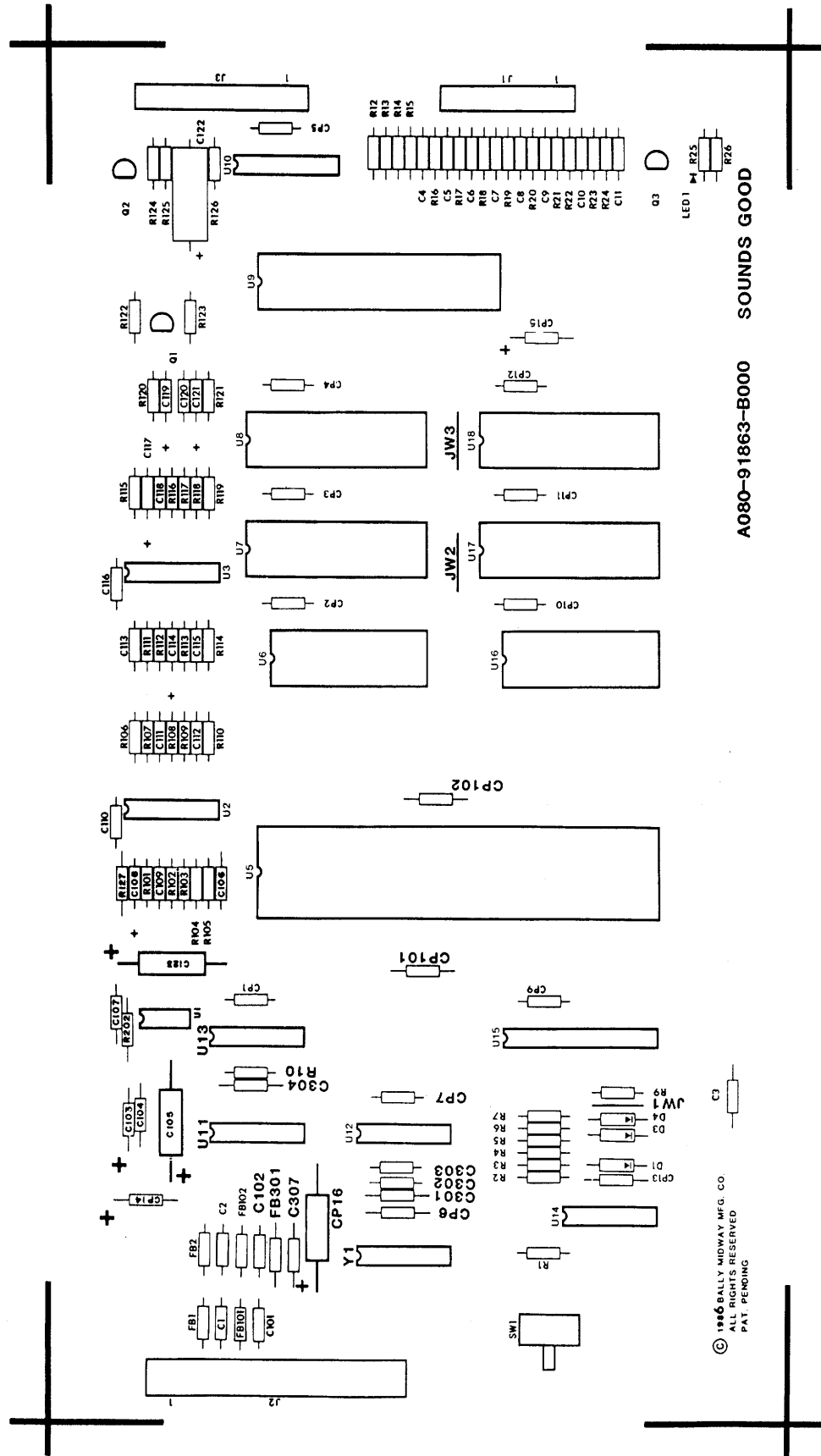

PROJECT ENG: C. MEDNICK		USED ON	
DO NOT SCALE DWG.		SCALE FULL	
HEAT TREAT		NO. REQ'D	
MATERIAL FINISH		ASSEMBLY DRAWING	
DATE 6/21/86		SOUNDS GOOD	
DRL DBS		A084-91863-B000	
CDR CMM		PART NO. M051-00114-B150	
DATE		FRANKLIN PK. ILL.	
HOLE DIA		Bally / MIDWAY MFG. CO.	
CONCENTRICITY TYP .003		REVISIONS	
FRACTIONAL .1/64		6/3/86 Rel. for Production	
DECIMAL .005			
TOLERANCE .002-.000			

SOUNDS GOOD  
A084-91863-8000

M051-00114-B151

DESIGNATION LIST

DESIGNATION LIST

CROSS REFERENCE

<u>DESIGNATION</u>	<u>DESCRIPTION</u>	<u>DESIGNATION</u>	<u>DESCRIPTION</u>	<u>DESCRIPTION</u>	<u>QTY.</u>	<u>DESIGNATION</u>	<u>PART NUMBER</u>
R22	100K OHM 1/4W CRBN.	U14	74F32	68 PF AX CER 10%	1	C109	0307-00800-0011
R23	10K OHM 1/4W CRBN.	U15	SG01R0 PAL	100 PF AX CER	7	C3-C5,C8-C11	0304-00800-0001
R24	100K OHM 1/4W CRBN.	U16	RAM 2K X 8	150 PF AX CER 10%	2	C111,C301	0307-00800-0010
R25	100 OHM 1/4W CRBN.	U17,U18	ROM/EPROM	270 PF AX CER 10%	2	C113,C118	0307-00800-0009
R26	47K OHM 1/4W CRBN.			390 PF AX CER	4	C1,C2,C101,C102	0986-00800-3000
R101	12K OHM 1/4W CRBN.	FB1,FB2	FERRITE BEAD	470 PF AX CER 10%	3	C112,C302,C303	0307-00800-0008
R102	160K OHM 1/4W CRBN.	FB101,FB102	FERRITE BEAD	680 PF AX CER	1	C106	0358-00800-0002
R103	100 OHM 1/4W CRBN.	FB301	FERRITE BEAD	820 PF AX CER	2	C6,C7	0304-00800-0002
R104	330K OHM 1/4W CRBN.			5600 PF AX CER 10%	1	C115	0307-00800-0007
R105	24K OHM 1/4W CRBN.	ICS U5	64 PIN IC SOCKET	.01 MF AX CER	17	C104,C107,C110	0986-00800-2200
R106	3.3K OHM 1/4W CRBN.	ICS U6	24 PIN IC SOCKET .600			C116,C120,CP1-CP7, CP9-CP13	
R107	24K OHM 1/4W CRBN.	ICS U7,U8	28 PIN IC SOCKET			C304,C307,CP101,CP102	0986-00800-0200
R108	150K OHM 1/4W CRBN.	ICS U9	40 PIN IC SOCKET	0.1 UF AX CER	4	C103,C108,C114,C117	0307-00800-0004
R109	82K OHM 1/4W CRBN.	ICS U10	16 PIN IC SOCKET	1 MF RD TANT	4	CP14,CP15	0986-00800-0700
R110	510K OHM 1/4W CRBN.	ICS U15	24 PIN IC SOCKET .300	10 MF AX TANT	2	C119,C121	0307-00800-0005
R111,R112	120K OHM 1/4W CRBN.	ICS U16	24 PIN IC SOCKET .600	10 MF RD TANT	2	C105,C122	0307-00800-0003
R113	33K OHM 1/4W CRBN.	ICS U17,U18	28 PIN IC SOCKET	47 MF AX ELECT	2	CP16,C123	0307-00800-0006
R114	330K OHM 1/4W CRBN.			100 MF AX ELECT	2	R17,R18,R25,R103, R202	100E-00005-0033
R115	150K OHM 1/4W CRBN.	J1	AUTO INSERT PIN TIN .025 SQ.	100 OHM 1/4W CRBN	5	R125	100E-00005-0039
R116	33K OHM 1/4W CRBN.	J2	AUTO INSERT PIN TIN .045 SQ.	180 OHM 1/4W CRBN	1	R123,R124	100E-00005-0048
R117	18K OHM 1/4W CRBN.	J3	AUTO INSERT PIN TIN .025 SQ.	360 OHM 1/4W CRBN	2	R10,R121	100E-00005-0061
R118	100K OHM 1/4W CRBN.			1K OHM 1/4W CRBN	2	R122,R126	100E-00005-0071
R119	510K OHM 1/4W CRBN.	JW1-JW3	ZERO OHM RESISTOR	2.7K OHM 1/4W CRBN	2	R106	100E-00005-0074
R120	47K OHM 1/4W CRBN.			3.3K OHM 1/4W CRBN	1	R1-R3,R6-R7,R9	100E-00005-0079
R121	1K OHM 1/4W CRBN.	LED 1	GREEN LED	4.7K OHM 1/4W CRBN	9	R12-R14	
R122	2.7K OHM 1/4W CRBN.			10K OHM 1/4W CRBN	7	R4,R15,R16,R19-R21, R23	100E-00005-0088
R123,R124	360 OHM 1/4W CRBN.	SW1	SWITCH PC MTG.	12K OHM 1/4W CRBN	1	R101	100E-00005-0090
R125	180 OHM 1/4W CRBN.			18K OHM 1/4W CRBN	1	R117	100E-00005-0093
R126	2.7K OHM 1/4W CRBN.	Y1	16 MHZ XSTAL OSC.	24K OHM 1/4W CRBN	2	R105,R107	100E-00005-0097
R127	560K OHM 1/4W CRBN.			33K OHM 1/4W CRBN	2	R113,R116	100E-00005-0100
R202	100 OHM 1/4W CRBN.			47K OHM 1/4W CRBN	2	R26,R120	100E-00005-0104
D1	NOT INSERTED			82K OHM 1/4W CRBN	1	R109	100E-00005-0112
D3-D4	1N5817			100K OHM 1/4W CRBN	4	R5,R22,R24,R118	100E-00005-0115
Q1-Q3	2N5305			120K OHM 1/4W CRBN	2	R111,R112	100E-00005-0118
U1	MC3340			150K OHM 1/4W CRBN	2	R108,R115	100E-00005-0120
U2,U3	LM359			160K OHM 1/4W CRBN	1	R102	100E-00005-0121
U5	68000G8 CPU			330K OHM 1/4W CRBN	2	R104,R114	100E-00005-0128
U6	RAM 2K X 8			510K OHM 1/4W CRBN	2	R110,R119	100E-00005-0133
U7,U8	ROM/EPROM			560K OHM 1/4W CRBN	1	R127	100E-00005-0134
U9	6821 P.I.A.						
U10	AD7533JN DAC			1N5817	2	D3-D4	103E-00003-0009
U11	14584/40106			2N5305	3	Q1-Q3	0360-00802-0012
U12	74S74			74LS04	1	U13	0304-00803-0060
U13	74LS04			74F32	1	U14	0304-00803-0059

SOUNDS GOOD  
A084-91863-B000  
M051-00114-B151

CROSS REFERENCE

DESCRIPTION	QTY.	DESIGNATION	PART NUMBER
74S74	1	U12	0304-00803-0061
14584/40106	1	U11	0304-00803-0056
6821 PIA	1	U9	0304-00803-0054
68000G8 CPU	1	U5	0304-00803-0051
AD7533JN DAC	1	U10	0304-00803-0055
SG01R0 PAL	1	U15	0E36-00803-0009
LM359	2	U2,U3	0304-00803-0053
MC3340	1	U1	0358-00803-0002
RAM 2KX8	2	U6,U16	0304-00803-0057
ROM/EPROM	1	U7	SEE ROM/EPROM CHART
ROM/EPROM	1	U8	
ROM/EPROM	1	U17	
ROM/EPROM	1	U18	
FERRITE BEAD	5	FB1,FB2,FB101,FB102,FB301	0316-00804-0002
16 PIN IC SOCKET	1	ICS U10	110E-00001-0003
24 PIN IC SOCKET .300	1	ICS U15	110E-00001-0009
24 PIN IC SOCKET .600	2	ICS U6,U16	110E-00001-0007
28 PIN IC SOCKET	4	ICS U7,U8,U17,U18	110E-00001-0010
40 PIN IC SOCKET	1	ICS U9	110E-00001-0011
64 PIN IC SOCKET	1	ICS U5	110E-00001-0016
AUTO INSERT PIN TIN .025 SQ	8	J1	0304-00804-0009
AUTO INSERT PIN TIN .025 SQ	11	J3	0304-00804-0009
AUTO INSERT PIN TIN .045 SQ	11	J2	0304-00804-0010
ZERO OHM RES	3	JW1-JW3	117E-00001-0003
GREEN LED	1	LED 1	119E-00001-0001
SWITCH PC MTG	1	SW1	0986-00804-3100
16 MHZ XSTAL OSC	1	Y1	0304-00804-0008
PC BOARD	1		A080-91671-G000

6-13-86 Released for Production, CMM.  
6-26-86 Rev. 1.0 CMM - Changed R101 from 24K to 12K.  
8-05-86 Rev. 2.0 CMM - Removed D1.  
8-28-86 Rev. 3.0 CMM - Changed C301 from 330PF to 150PF.

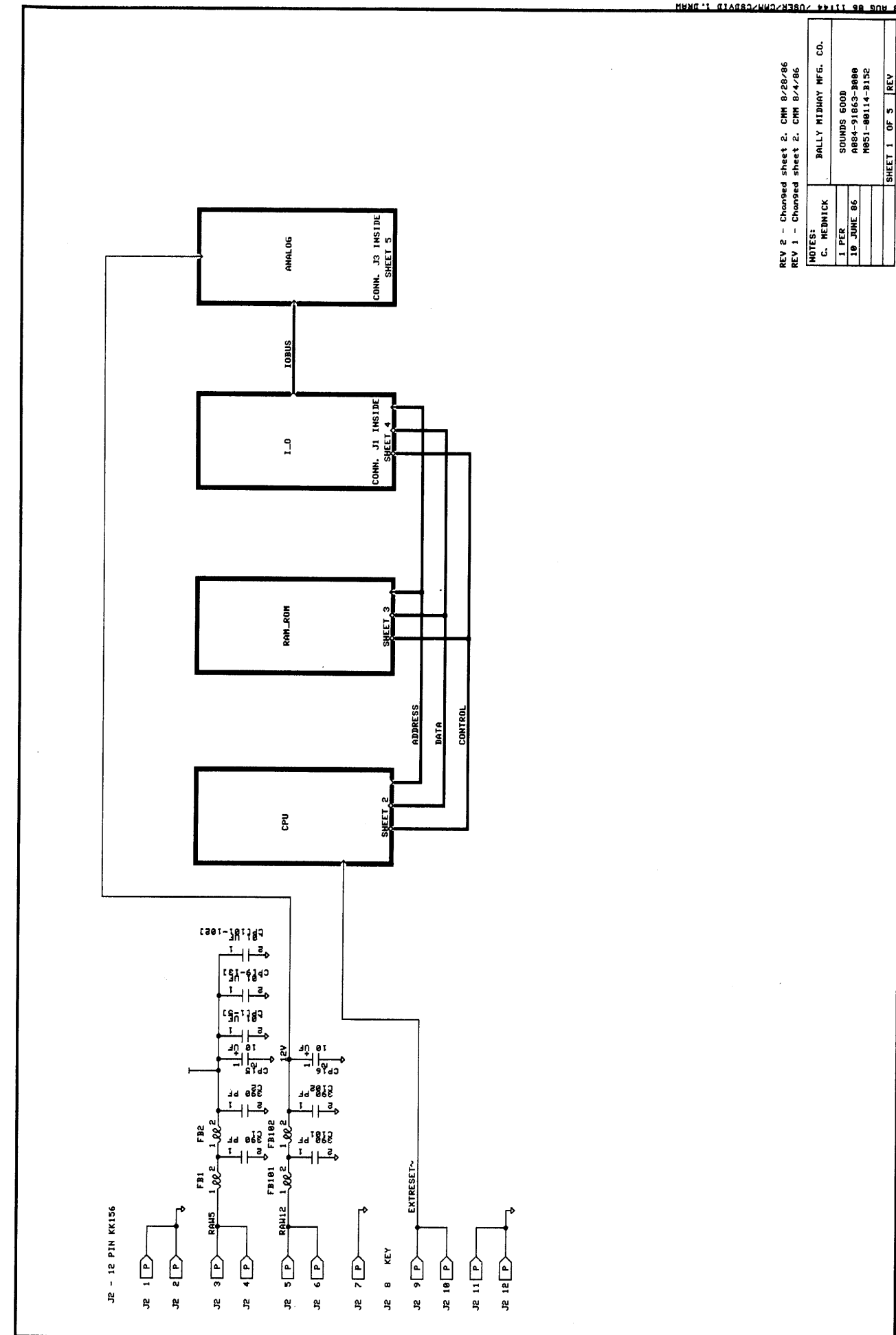

REV 2 - Changed sheet 2, CMM 8/28/86  
REV 1 - Changed sheet 2, CMM 8/4/86

NOTES:  
C. HEINICK  
1 PER  
18 JUNE 86

BALLY MIDWAY MFG. CO.  
SOUNDS GOOD  
A084-91863-B000  
M051-00114-B151

SHEET 1 OF 5 REV

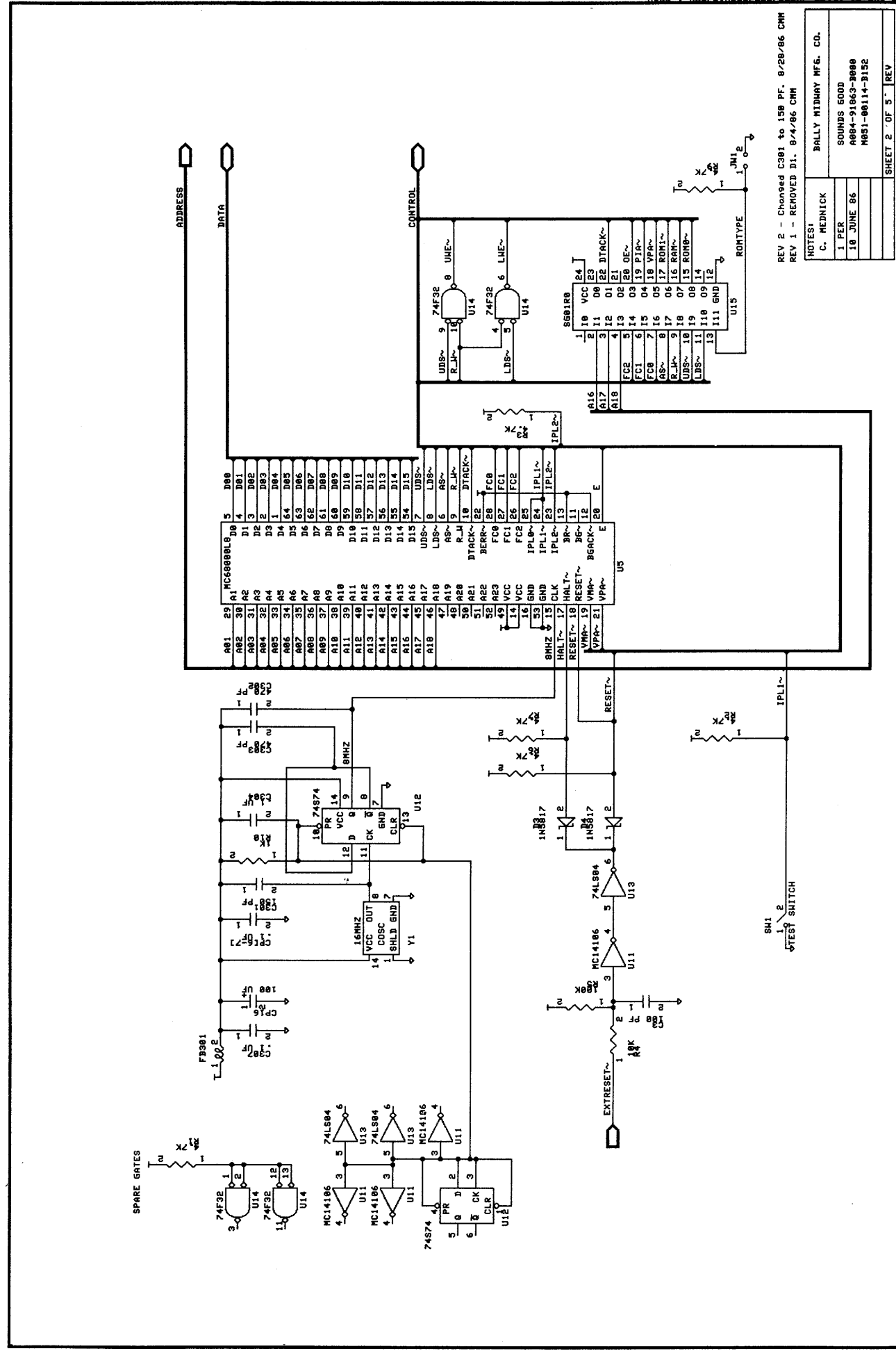

REV 2 - Changed C301 to 150 PF, 8/28/86 CMH  
 REV 1 - REMOVED D1, 8/4/86 CMH

NOTES:  
 BALLY MIDWAY MFG. CO.  
 SOUNDS GOOD  
 A884-91863-3080  
 10 JUNE 86  
 M851-80114-3152

SHEET 2 OF 5 REV

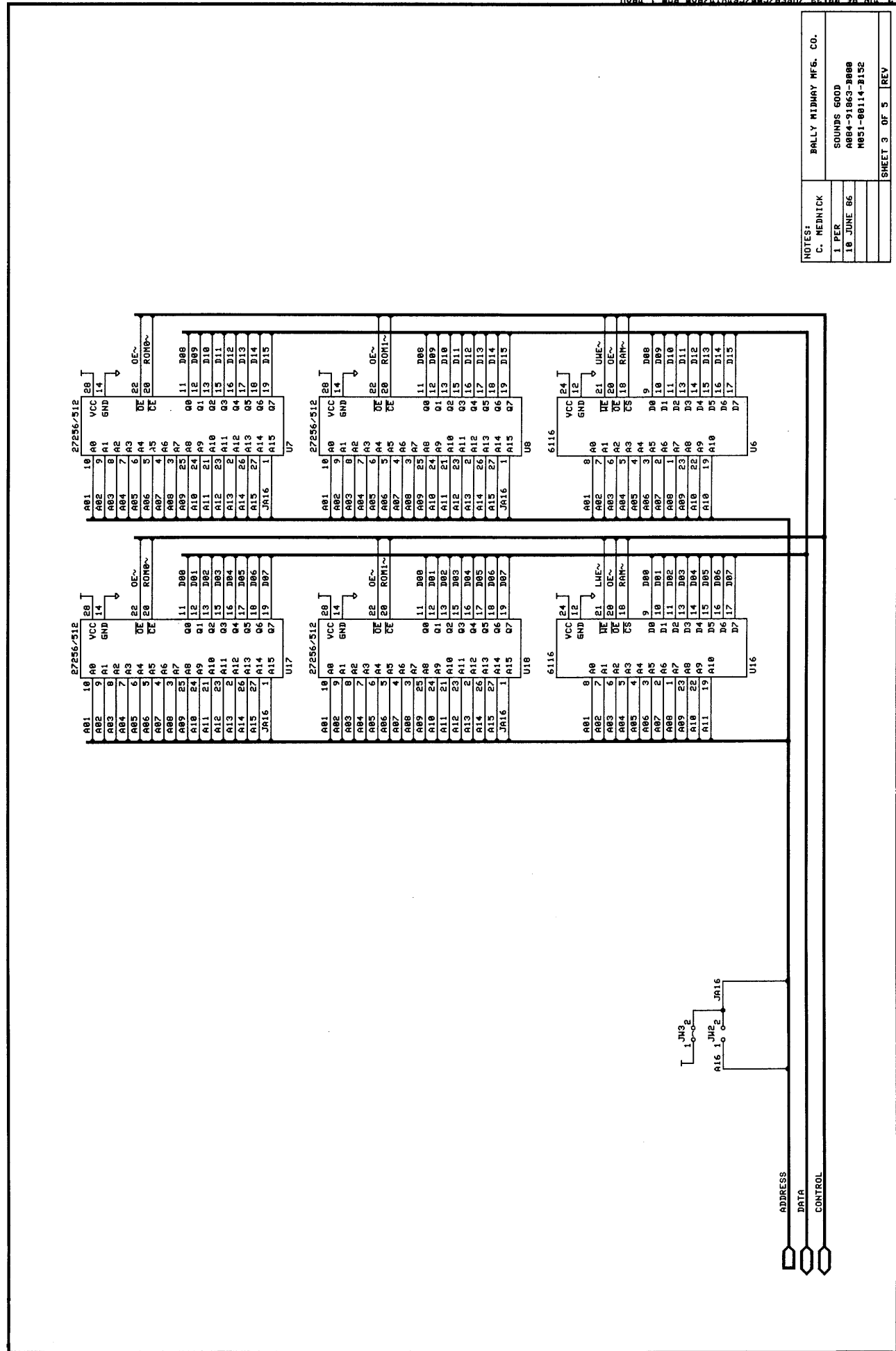

NOTES:  
 BALLY MIDWAY MFG. CO.  
 SOUNDS GOOD  
 A884-91863-3080  
 10 JUNE 86  
 M851-80114-3152

SHEET 3 OF 5 REV

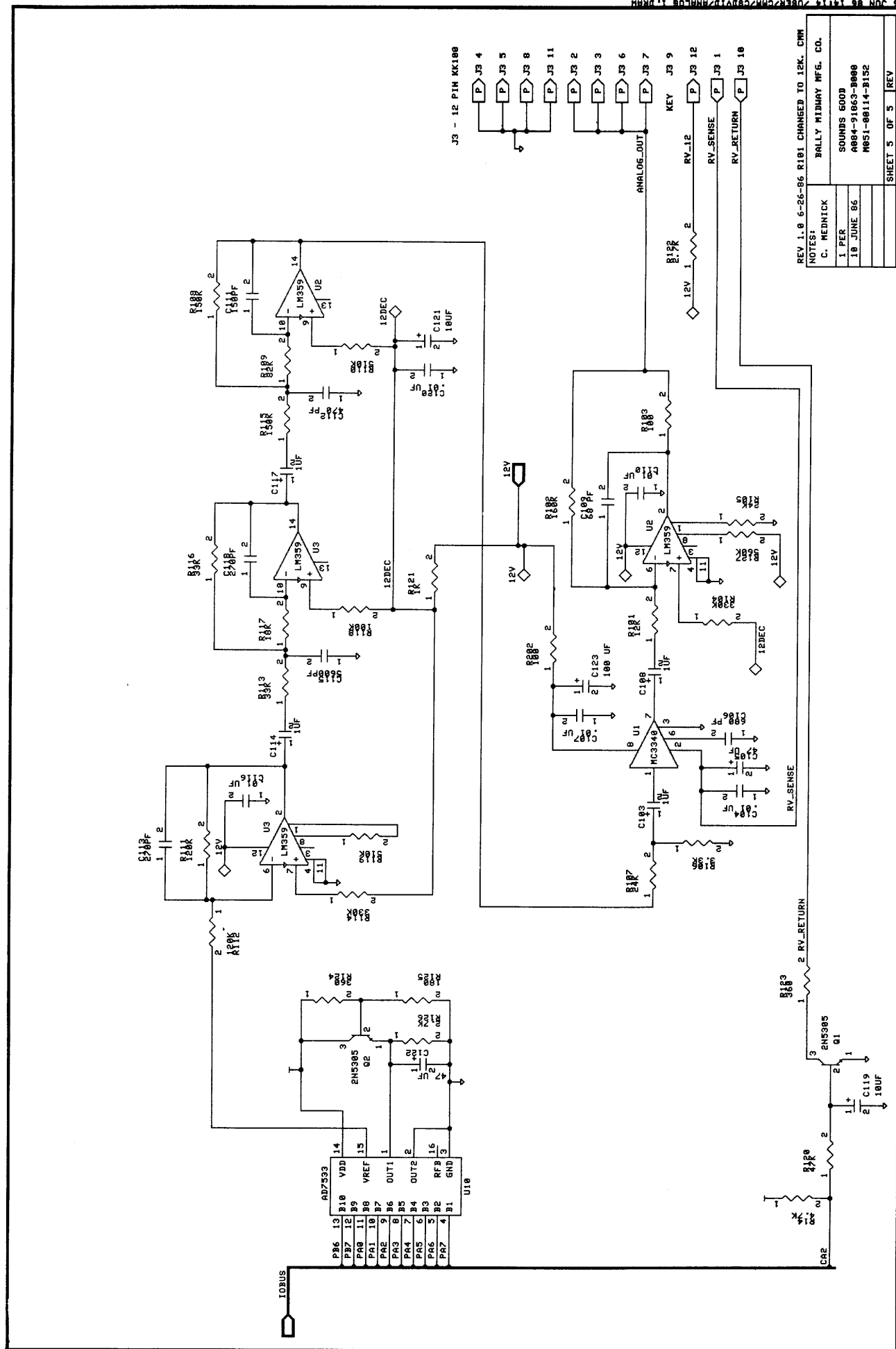
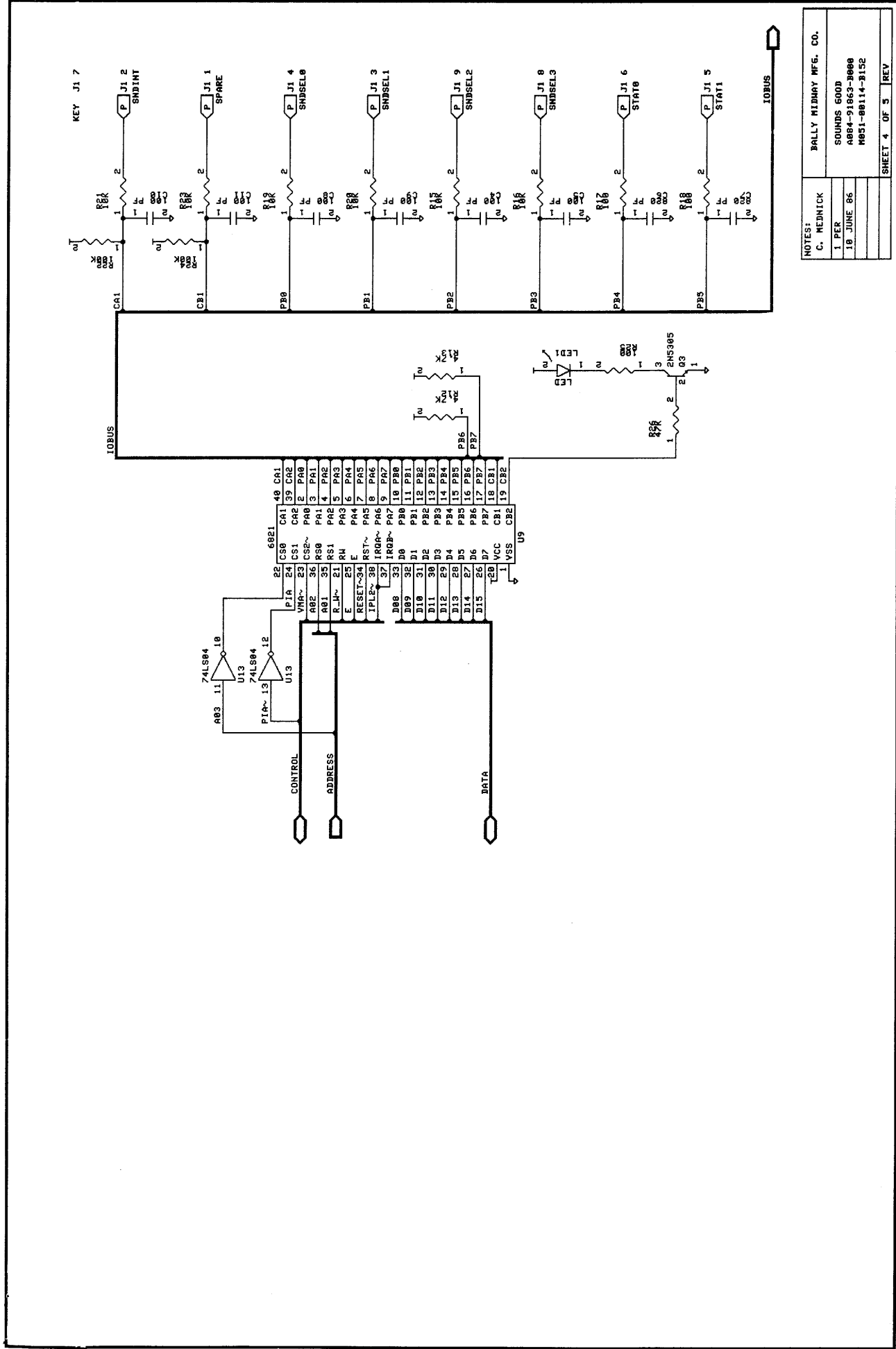

**DESIGNATION LIST**

DESIGNATION NO.	DESCRIPTION
C1,C2	4.7 MF 25V RD TANT
C3,C4	22 MF 6V RD TANT
C5,C6	470 MF 6V AX ELEC
C7-C10	.1 MF 50V AX CER
CP1	220 MF 25V AX ELEC
CP2,CP3	.1 MF 50V AX CER
R1,R2	2.7K OHM 1/4W 5% CRBN
R3,R4	27 OHM 1/4W 5% CRBN
R5-R8	1 OHM 1/2W 5% CRBN
U1,U2	MB3730
J1	7 PIN
J2	5 PIN
HSA1,2	HEATSINK ASSY
MH1-MH4	1/4" SPACER

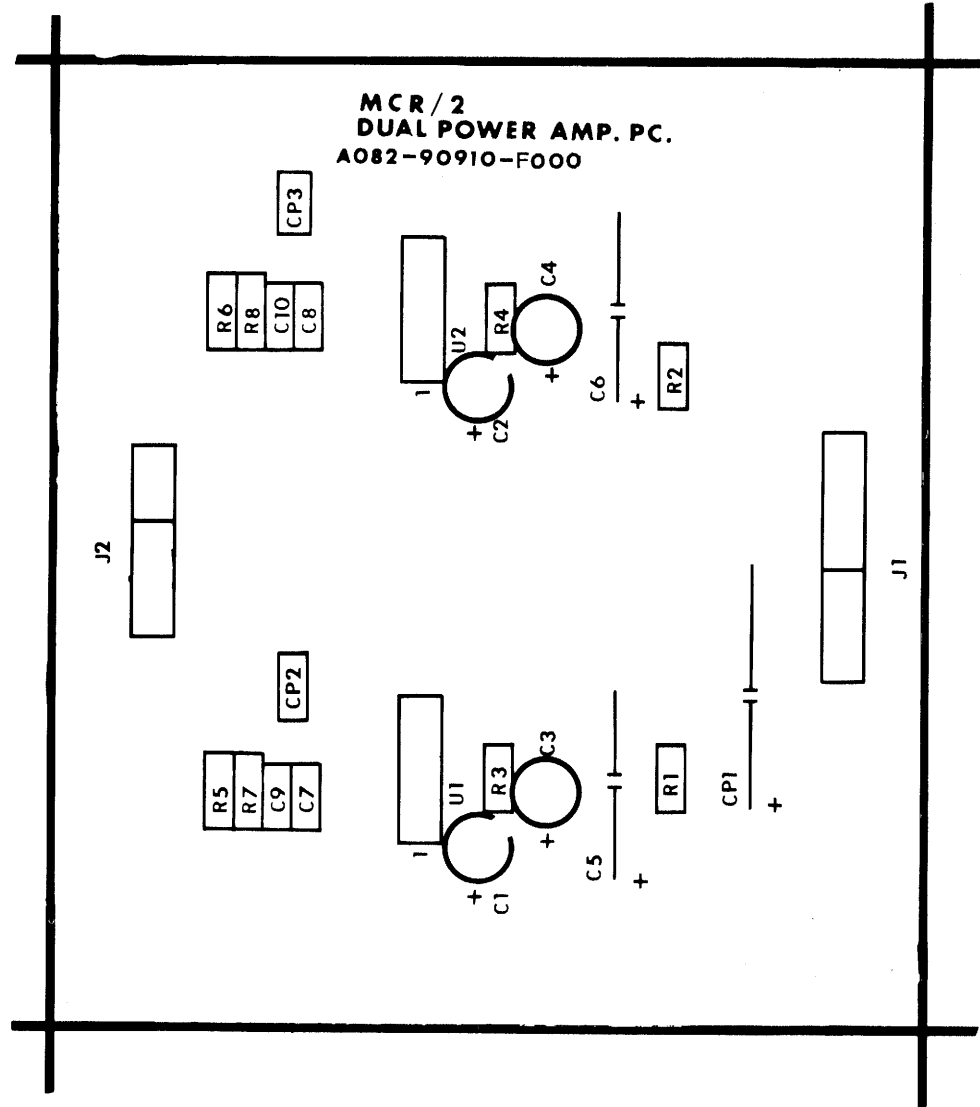

**CROSS REFERENCE LIST**

DESCRIPTION	QTY	DESIGNATION NO.	PART NUMBER
.1 MF 50V AX CER	6	C7-C10, CP2, CP3	0986-00800-1100
4.7 MF 25V RD TANT	2	C1, C2	0986-00800-3100
22 MF 6V RD TANT	2	C3, C4	0986-00800-1600
220 MF 25V AX ELEC	1	CP1	0986-00800-3200
470 MF 6V AX ELEC	2	C5, C6	0986-00800-1700
1 OHM 1/2W 5%	4	R5-R8	0062-02603-1XXX
27 OHM 1/4W 5%	2	R3, R4	0062-06803-1XXX
2.7K OHM 1/4W 5%	2	R1, R2	0062-19903-1XXX
MB3730	2	U1, U2	0066-188XX-XX4X
TIN .045 SQ PINS	12	J1, J2	0017-00033-0480
HEATSINK ASSY	2	HSA1, 2	A986-00010-E000
1/4" SPACER	4	MH1-MH4	0017-00042-0320
PC BOARD	1		A080-90910-F000

PROJECT ENG: C. MEDNICK

THIS DWG IS CONFIDENTIAL & PROPERTY OF BALLY/MIDWAY MFG. CO.

<b>DIM. TOLERANCES</b> UNLESS OTHERWISE SPEC. CONCENTRICITY T.I.R. .002 FRACTIONAL ± 1/64 DECIMAL ± .005 HOLE DIA. +.002-.000 ANGLE ± 1/2° <b>DO NOT SCALE DWG.</b>	FIRST USED ON <b>TRON</b>			 <b>Bally/MIDWAY MFG. CO.</b> FRANKLIN PARK, IL 60131	<b>REVISIONS</b>
	DRN	DATE	SCALE		
	MECH CHK	MAT'L			
	ELEC CHK	FINISH			
DUAL PWR AMP ASSEMBLY DRWG A084-90910-F000				PART NO. <b>M051-00986-F010</b>	



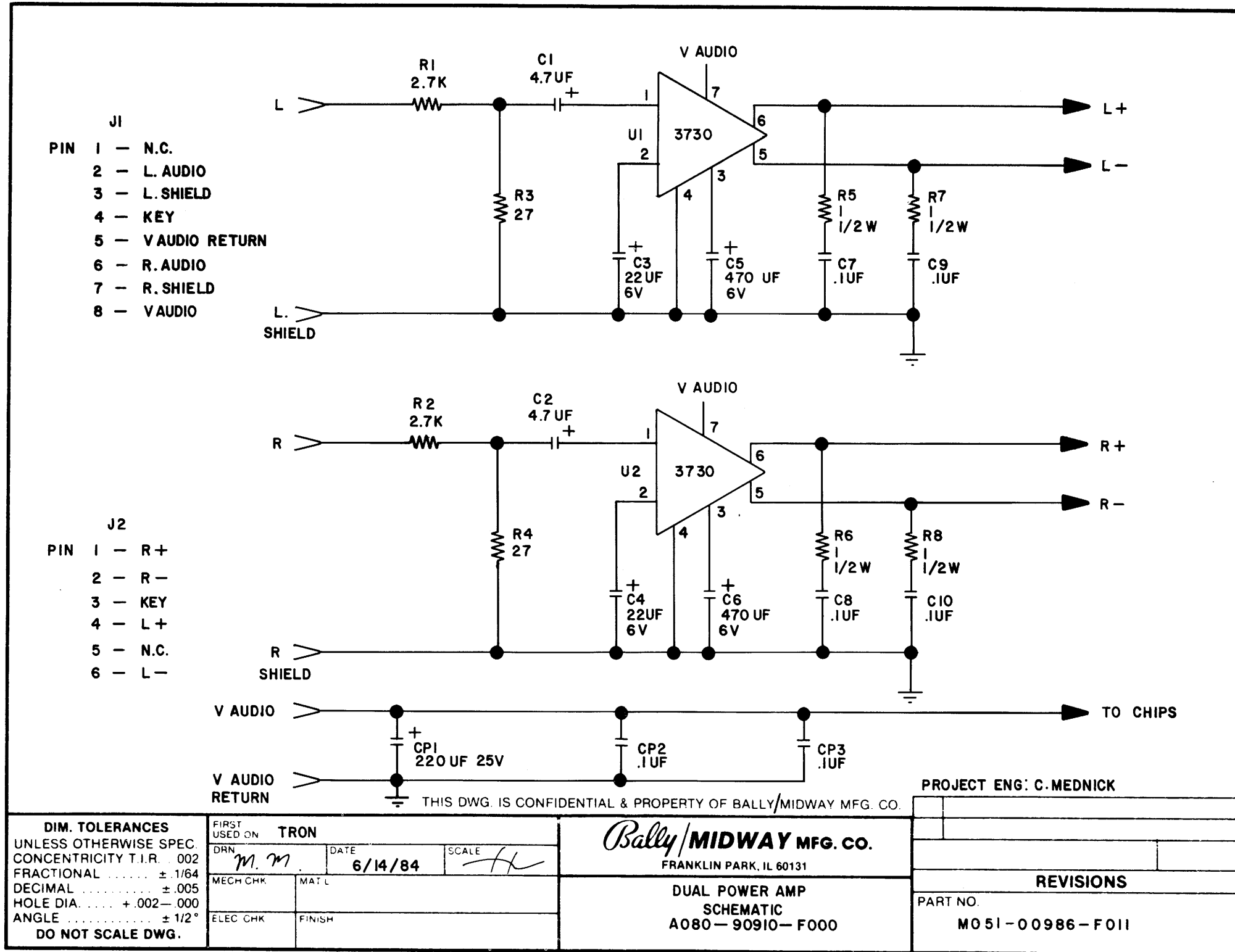

BRUNING-40-107

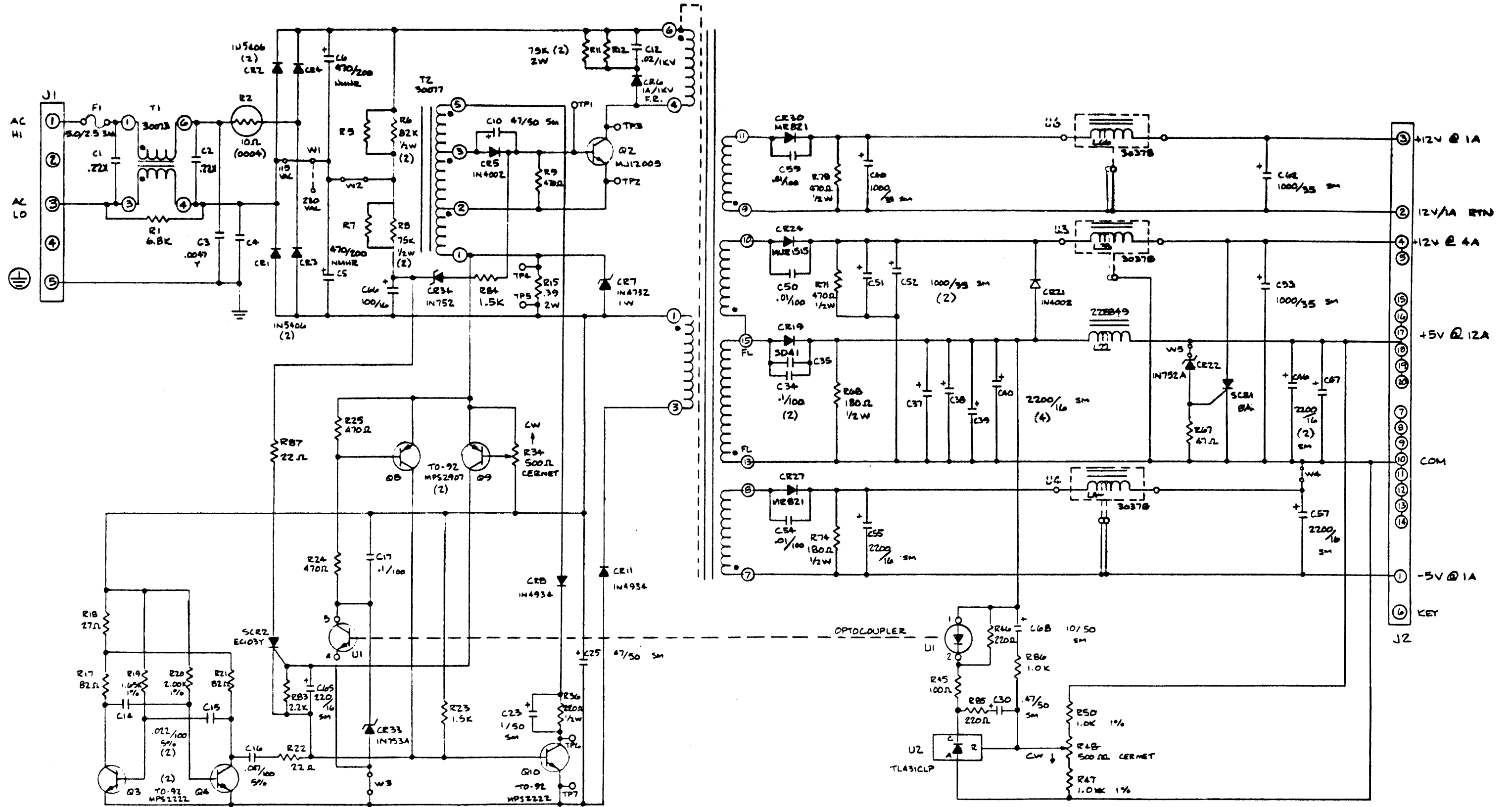

3-30 2. CAPACITOR VALUES IN MICROFARAD/VOLTS.  
 1. RESISTOR VALUES ARE IN OHMS 1/2W, 5%, C.F.  
 NOTES: UNLESS OTHERWISE SPECIFIED.

FOR ADDITIONAL ELECTRICAL INFORMATION,  
 REFER TO MECH. DWG. NO. 0017-00003-0543.

0017-00003-0543 M051-00945-A087

QTY	PRC	PART OR IDENTIFYING NO.	DESCRIPTION OR DESCRIPTION	MATERIAL SPECIFICATION
PARTS LIST				
UNLESS OTHERWISE SPECIFIED DIMENSIONS ARE IN INCHES TOLERANCES ARE: FRACTIONS DECIMALS ANGLES		CONTRACT NO.		CAMARILLO, CALIF 93010 (805) 484-2851
MATERIAL		APPROVALS	DATE	
POWER		CHECKED		SCHEMATIC SPI016
NEXT ASSY	USED ON	ISSUED		
APPLICATION		DO NOT SCALE DRAWING		SIZE / PCH NO. / DWG NO. D / / 31-SPI016

A945-00059-0000/0100/0200  
UNI PWR SUPPLY CHASSIS ASS'Y # 125 SWUR + 125 SWCT

	105	115	210	220	230	240
BLK	5-8	5-11	8-14	11-14	11-14	11-14
BRN	14-15	14-15	—	—	—	—
BLU	4-7	4-10	4-7	4-7	4-10	4-13

- NOTES: 1. JUMPERS ON CONN "A" 3-6 AND 9-12 CAN BE REPLACED WITH A SAFETY SW. AND/OR AUX. ON OFF SW.  
2. MODEL A945-00059-0200 HAS A TERMINAL STRIP.  
MODEL A945-00059-0100 HAS A ON/OFF SWITCH.  
MODEL A945-00059-0000 HAS A ON/OFF SWITCH.

TRANSFORMER  
MT00-00136-A000 (U.R.)  
MT00-00136-B000 (C.T.)

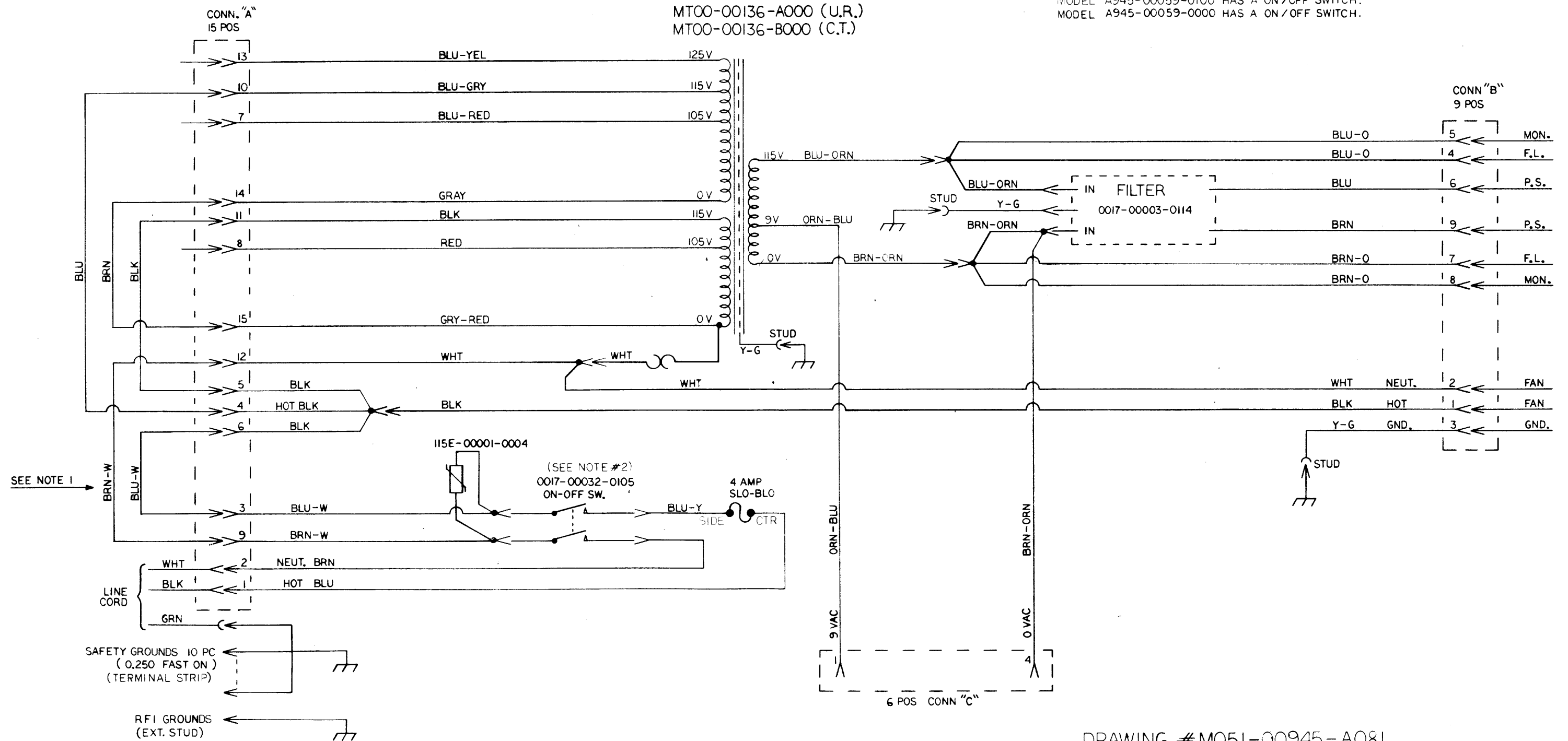

DRAWING # M051-00945-A081  
REL FOR PRODUCTION: 4/26/85

FCC FILTER BOARD FOR MONOBOARD  
 PART NO. A084-91870-A000  
 M051-00E36-A161

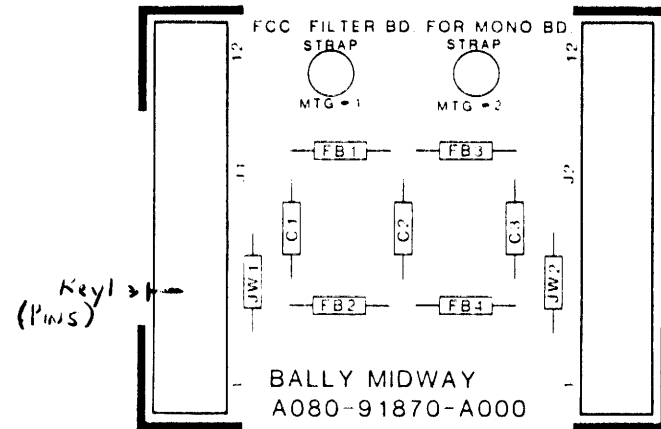

DESIGNATION LIST

DESIGNATION NUMBER

DESCRIPTION

C1 - C3	.01 UF AX. CER.
FB1 - FB4	FERRITE BEAD
J1	CONNECTOR 12 PIN KK156 R/A
J2	HEADER 12 PIN KK156 R/A OMIT PIN 5
JW1 - JW2	JUMPER WIRE
KEY 1	KK156 KEY FOR PIN 5 OF J1

CROSS REFERENCE LIST

<u>DESCRIPTION</u>	<u>QTY.</u>	<u>DESIGNATION NO.</u>	<u>PART NOS.</u>
.01 UF AX. CER	3	C1 - C3	0360-00800-0005
FERRITE BEAD	4	FB1 - FB4	0316-00804-0002
HEADER 12 PIN KK156 R/A OMIT PIN 5	1	J2	0E36-00804-0002
CONNECTOR 12 PIN KK156 R/A	1	J1	0E36-00804-0001
JUMPER WIRE	2	JW1 - JW2	117E-00001-0003
KK156 KEY	1	KEY 1	0017-00021-1353
P.C. BOARD	1		A080-91870-A000

8/13/86 - Released for Production - CMM  
 8/14/86 - Rev. 1 - corrected J1, J2 designation reversed.

REVISIONS	
8/13/86	Released For Production

PROJECT ENG: C. MEDNICK		USED ON RAMPAGE		Bally / MIDWAY MFG. CO. FRANKLIN PK. ILL.
DO NOT SCALE DWG.		NO. REQ'D 1		
DIM. TOLERANCES UNLESS SPECIFIED		ASSEMBLY DRAWING		M051-00E36-A160
CONCENTRICITY PER 005		F.C.C. FILTER FOR MONO BD.		
FRACTIONAL 1/64		(A084-91870-A000)		
DRM. 08/12/86	CKD. 08/21/86	DATE 8/13/86		

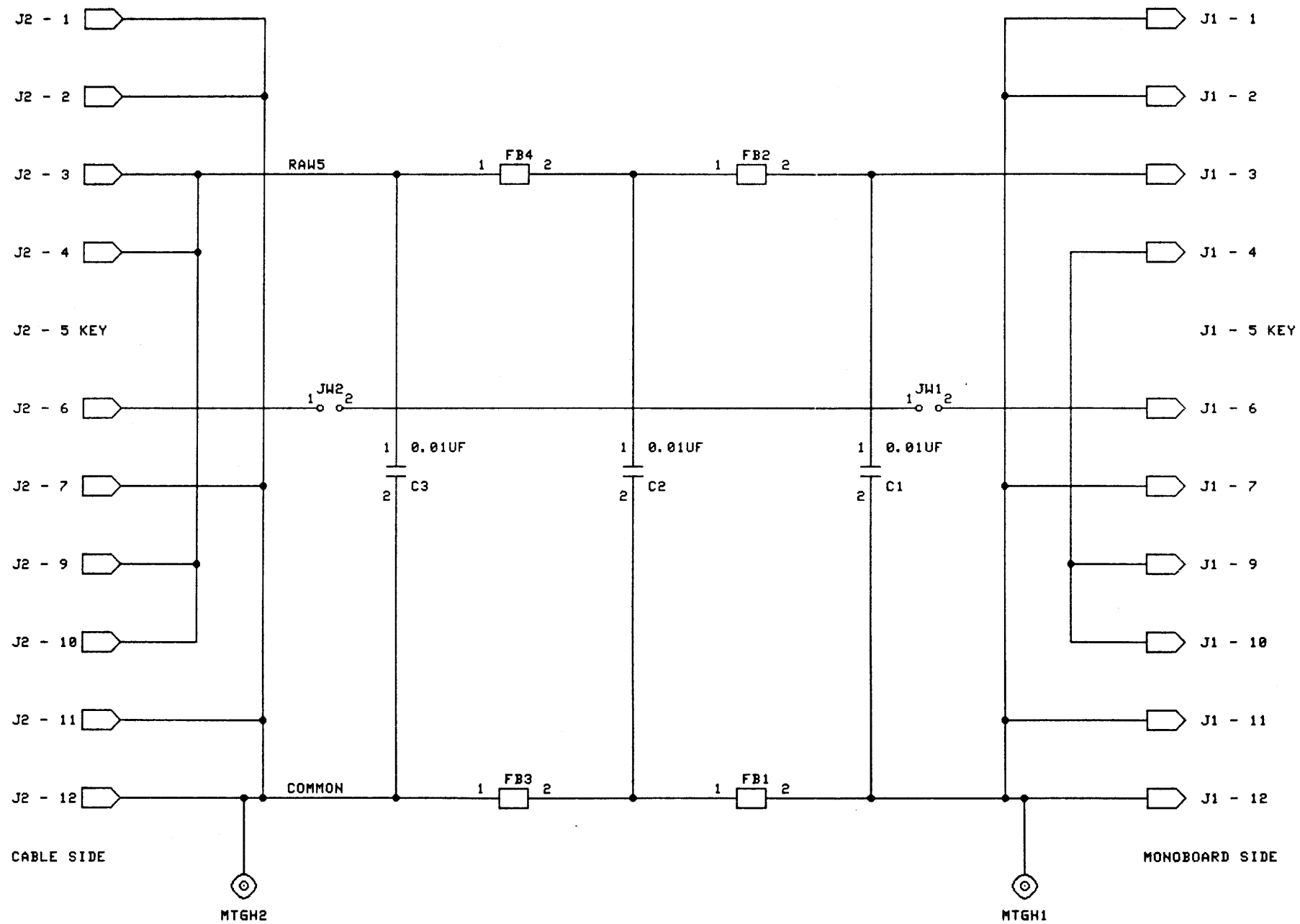

Released per Production 5/13/86

NOTES:	BALLY MIDWAY MFG. CO.
L. DEKKER	
8-11-86	
	FCC FILTER BOARD
	M051-00E36-A162
	A084-9187D-A000
	SHEET 1 OF 1 REV A

AUG 86 10:38 USER/JAN/FILTER.DJ I. DRAM

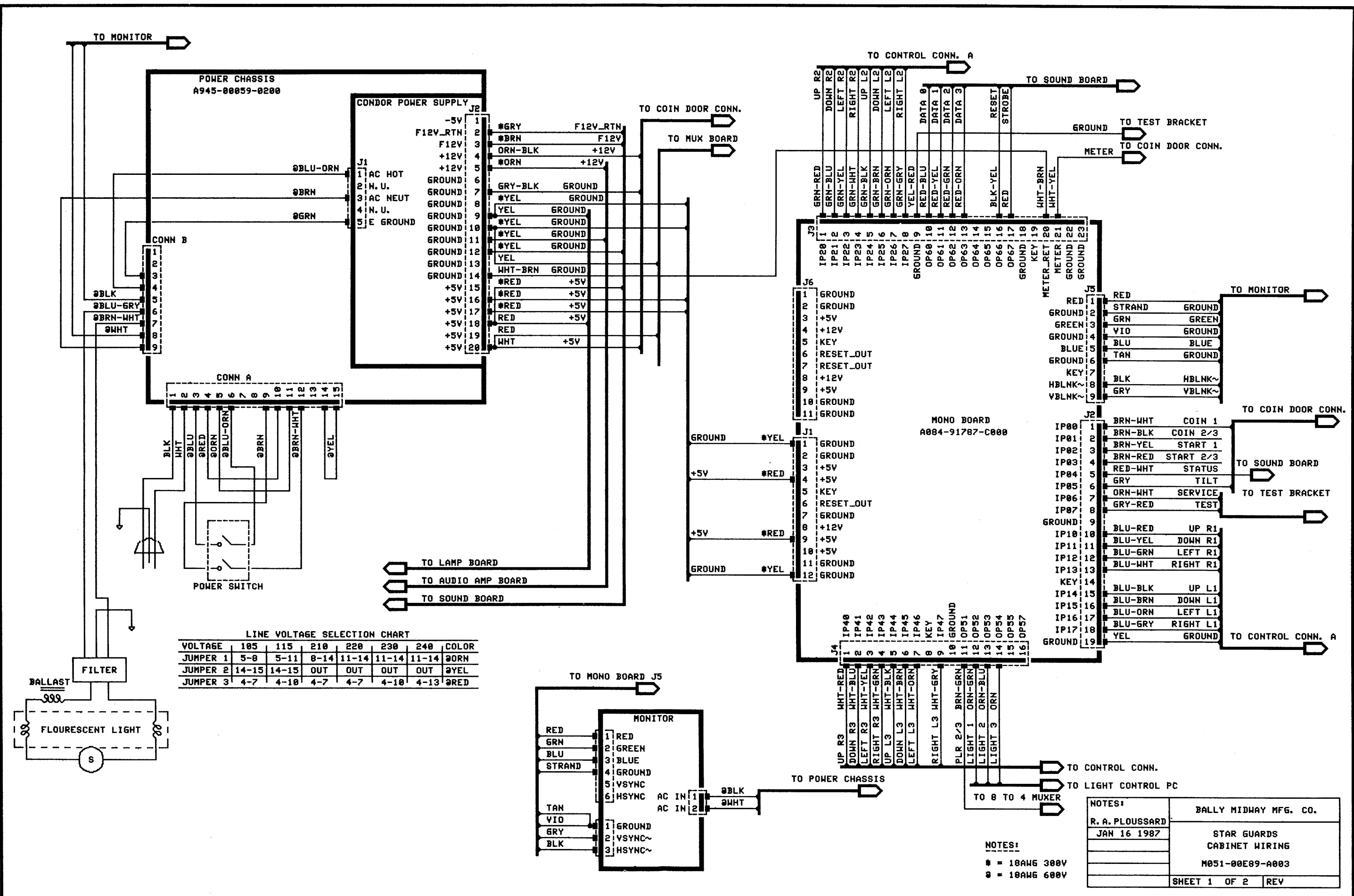

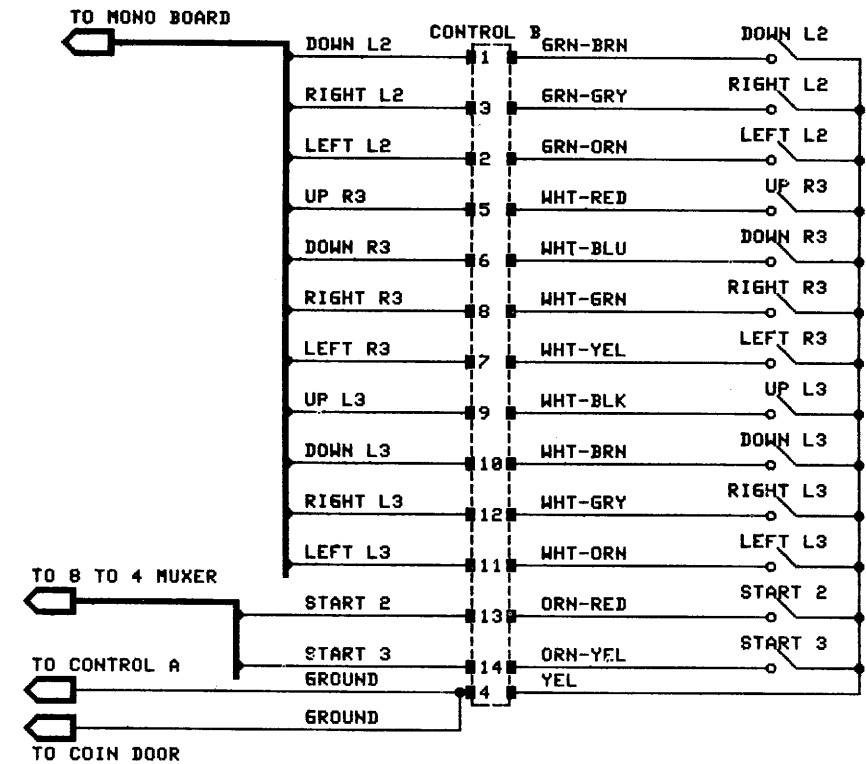
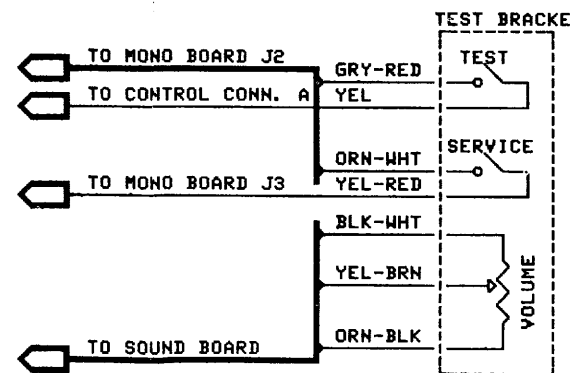
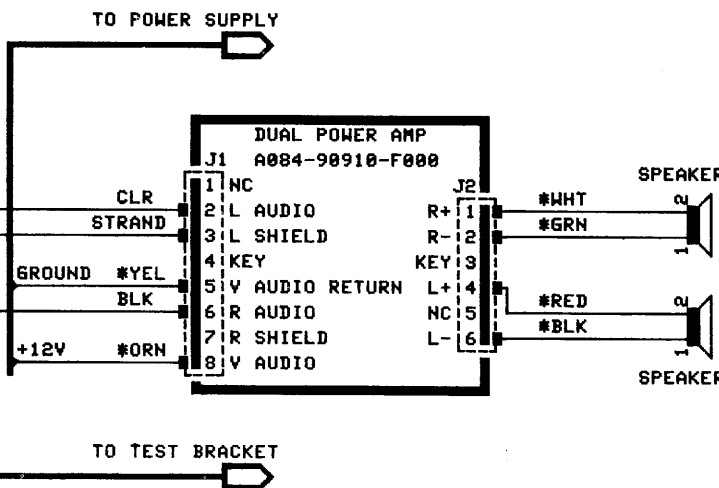
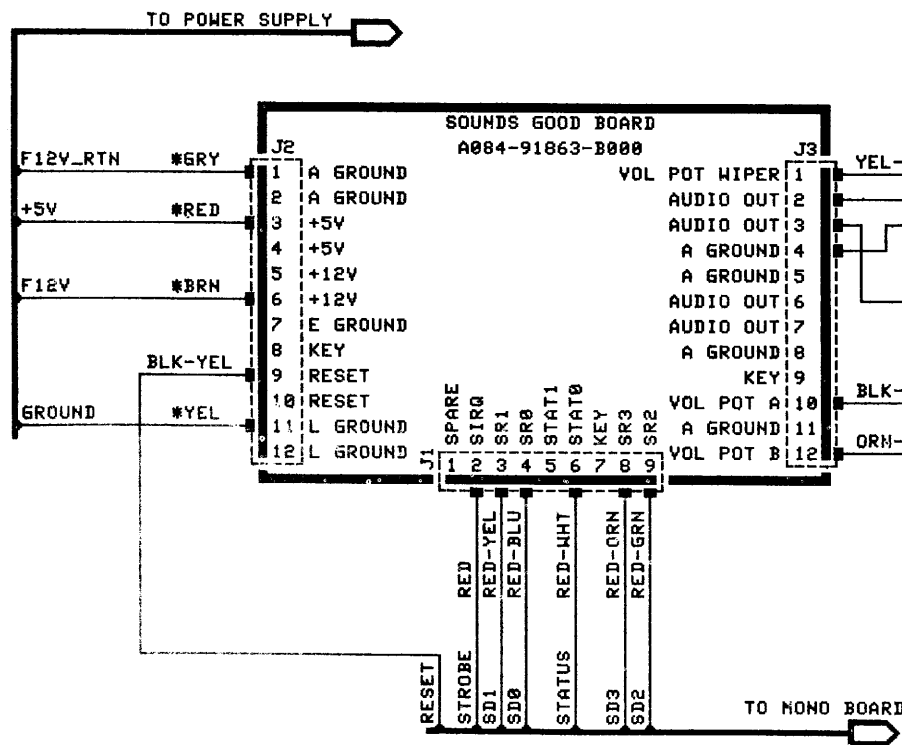
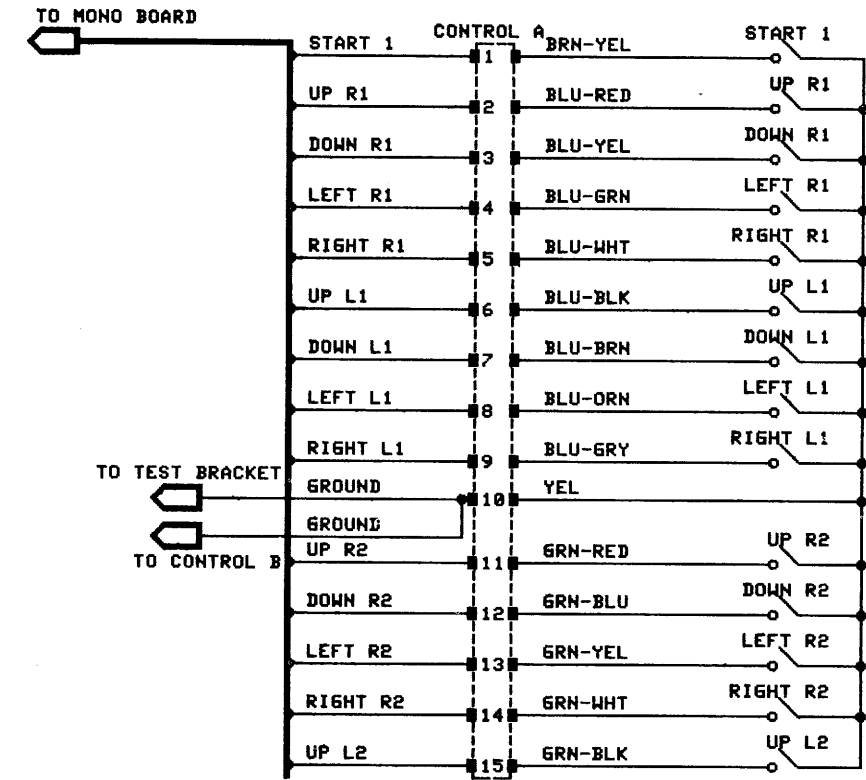
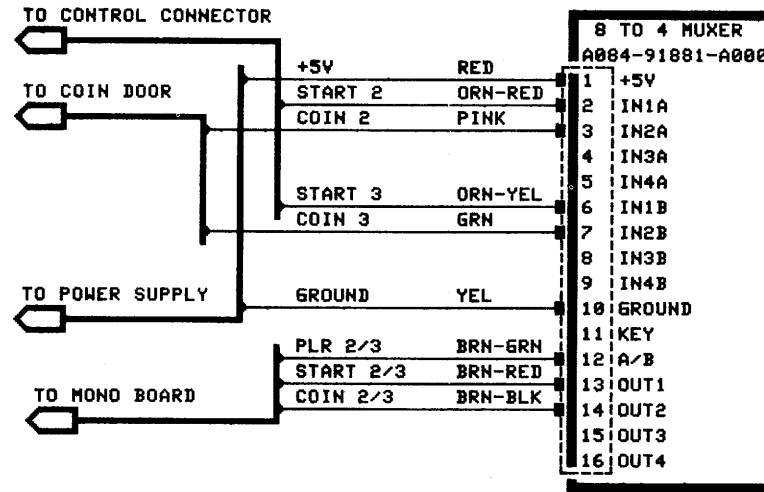
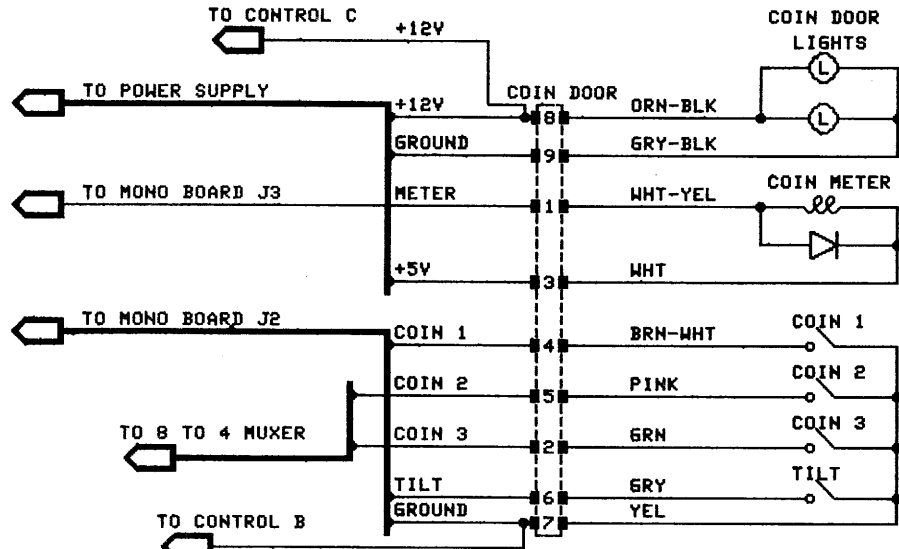
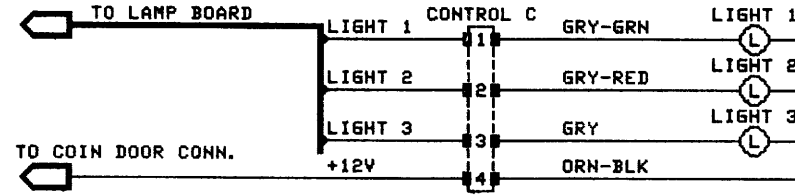
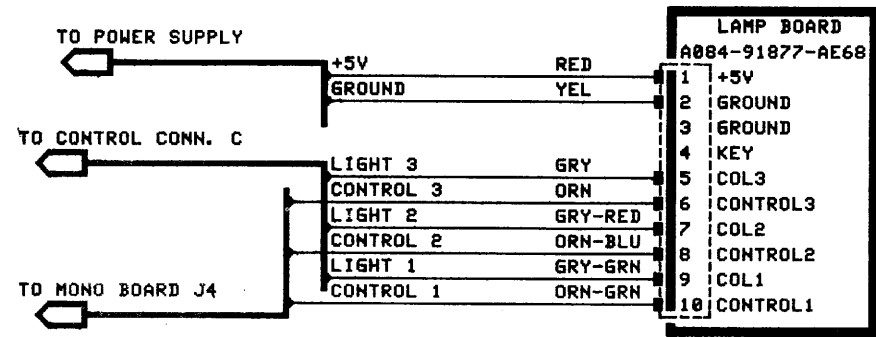

NOTES:  
\* = 18 AWG 300V

NOTES:	BALLY MIDWAY MFG. CO.
R. A. PLOUSSARD	STAR GUARDS
JAN 16 1987	CABINET WIRING
	M051-00E89-A003
	SHEET 2 OF 2 REV

16 JAN 87 11:49 USER/RAP/GAMES/FORMERS/CABINET 2. DRAM

8 TO 4 MULTIPLEXER BOARD  
A084-91881-A000  
M051-00114-A181

CROSS REFERENCE LIST

DESCRIPTION	QTY	DESIGNATION	PART NUMBER
100PF AX CER	9	C1-C9	0360-00900-0046
.01UF AX CER	1	CP2	0986-00800-2000
10UF AX TANT	1	CP1	0986-00800-0700
10K OHM 1/4W 5% RES.	9	R1-R9	100E-00005-0088
100K OHM 1/4W 5% RES	9	R10-R18	100E-00005-0115
74HC241	1	U1	0E89-00803-0001
AUTO INSERT PIN .025	15	J1	0304-00804-0009
PC BOARD	1		A080-91881-A000

DESIGNATION LIST

DESIGNATION	DESCRIPTION
CP1	10UF AX TANT
CP2	.01UF AX CER
C1-9	100PF AX CER
R1-R9	10K OHM RES
R10-R18	100K OHM RES
U1	74HC241
J1	AUTO INSERT PINS .025
PC BOARD	A080-91881-A000

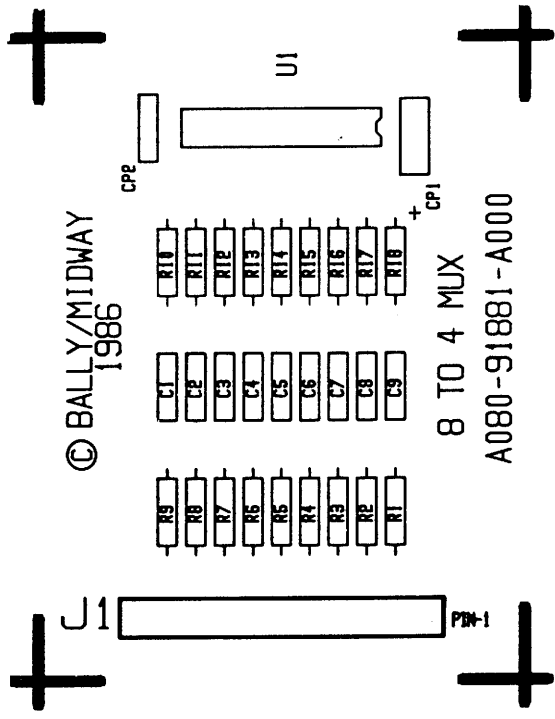

RELEASED 18 DEC 1986 RAP

B	WAS M051-00114-A181	15/87
A	New Re/Case	12/86

REVISIONS

PROJECT ENG: R. PLOUSSARD  
DO NOT SCALE DWG.  
HEAT TREAT  
MATERIAL  
FINISH  
DATE 12/22/86  
CONCENTRICITY T.I.R. .003  
FRACTIONAL .1/64  
DECIMAL .005  
HOLE DIA. +.002-.000

USED ON OE89  
SCALE FULL  
NO. REQ'D 1 PER

ASSEMBLY DRAWING  
8 TO 4 MUX. BD.  
(A084-91881-A000)

Bally / MIDWAY MFG. CO.  
FRANKLIN PK. ILL.

PART NO.  
M051-00114-A180

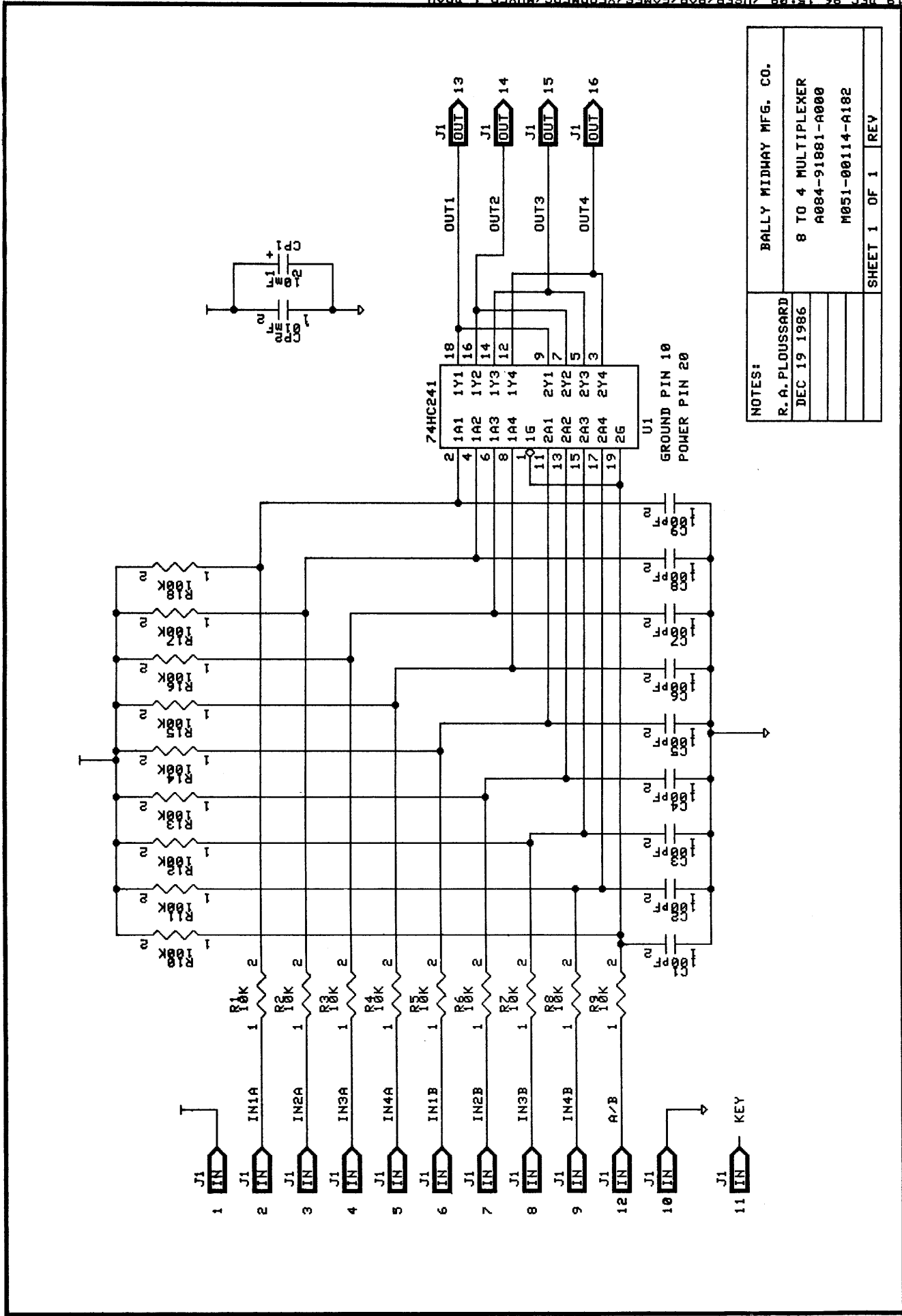

NOTES:

R. A. PLOUSSARD	BALLY MIDWAY MFG. CO.
DEC 19 1986	8 TO 4 MULTIPLEXER
	A084-91881-A000
	M051-00114-A182
	SHEET 1 OF 1 REV



**BALLY/MIDWAY'S STAR GUARDS (3 PLYR)**

**U.R. #0E89**

**ROM/EPROM PART NUMBERS**

**UNPROGRAMMED MONOBOARD A084-91787-F000**

**PROGRAMMED MONOBOARD A084-91787-AE68**

POS.	MIDWAY PART NUMBER
15A	0E89-00803-0006
14B	0E89-00803-0007
8E	0E89-00803-0013
6E	0E89-00803-0012
5E	0E89-00803-0011
4E	0E89-00803-0010
3B	0E89-00803-0008
5B	0E89-00803-0009
5H	0986-00803-9200

JUMPERS	IN	OUT
JW1		**
JW2	**	
JW3	**	
JW4		**
JW5	**	
JW6		**

**UNPROGRAMMED SOUNDS GOOD BOARD A084-91863-B000**

**PROGRAMMED SOUNDS GOOD BOARD A084-91863-AE68**

POS.	MIDWAY PART NUMBER
U17	0E89-00803-0002
U7	0E89-00803-0003
U18	0E89-00803-0004
U8	0E89-00803-0005

JUMPERS	IN	OUT
JW1		**
JW2		**
JW3	**	

<b>M051-00E89-A008</b>	<b>REVISIONS</b>
<b>01-20-87</b>	<b>RELEASE FOR PRODUCTION</b>