

namco[®]

Soul Edge[™]

Operators Manual

IT IS THE RESPONSIBILITY OF THE OPERATOR TO MAINTAIN CUSTOMER SAFETY
AT ALL TIMES, AND IT IS IMPERATIVE THAT THE DETAILS SET OUT IN THIS
MANUAL ARE FOLLOWED PRECISELY.

Part No. 90500084

No part of this publication may be reproduced by any mechanical, photographic or electronic process, or in the form of phonographic recording, nor may it be stored in a retrieval system, transmitted or otherwise copied for public or private use, without permission from
NAMCO EUROPE LTD.

While the information contained in this manual is given in good faith and was accurate at the time of publication, NAMCO EUROPE LTD. reserve the right to make changes and alterations without notice.

This machine has been manufactured in accordance with European Community directives (1st. January 1996), and as such bears the marking. Any changes or modifications to this machine must be in accordance with European Community directives (1st. January 1996).

If you make any unauthorised changes to this product, you may contravene European Community directives (1st. January 1996)

Published by:
NAMCO EUROPE LTD.
Namco House,
8 Acton Park Estate,
The Vale,
London. W3 7QE

Phone:- 0208-324-6000
Fax:- 0208-324-6010

SAFETY WARNING

In order to use this machine safely, be sure to read this Operators Manual carefully before installation, adjustment or use of this machine.

Whenever the owner of this machine entrusts disassembly, installation, adjustment, routine maintenance or trouble shooting to another person, the owner should ensure that that person read the appropriate precautions and relevant sections of this manual before starting work.

In order that no accidents occur when the machine is in operation, strictly follow the notes on safety described below. Also, carefully read section 2, "Precautions"

Warnings for Operation (C E Requirements)

NOTE: Only operate this machine after checking that it has been installed correctly and in accordance with the installation and commissioning manual.

NOTE: **If there is an error or problem with this machine, operation must be stopped immediately and the problem rectified before further use.**

Warnings for Disassembly, Installation, Routine Maintenance, and Troubleshooting.

DANGER: Namco Ltd. bears absolutely no responsibility for accidents or injuries resulting from unauthorized changes to this machine.

DANGER: Ensure that the machine has been turned **OFF** before making adjustments or carrying out maintenance. Also ensure only qualified personnel carry out maintenance or turn the power **ON** to this machine.

DANGER: The power supply and inside the monitor will remain hot and have areas of high voltage even though the machine has been turned OFF, and there is a possibility of burns or electric shock. Be careful not to touch these areas.

DANGER: In order to avoid injuries due to mis-operation, be sure that the voltage of the main power supply is within the prescribed limits. Also to prevent possible electric shocks due to failure, this machine **MUST** be fitted with a securely connected earthed plug.

NOTE: Do not turn the power switch **ON** until the machine has been installed correctly.

Contents

Operators Manual	1
SAFETY WARNING	3
1. SPECIFICATIONS	5
2. PRECAUTIONS	6
2-1 Cautions When Installing	6
2-2 Cautions when Handling.	6
2-3 Cautions when Transporting.....	6
2-4 Cautions when handling the PCB.	6
3. ADJUSTMENTS	7
3-1 Turning on the Power	7
3-2 Switches for Adjustment	7
3-4 Test Mode	8
3-4-1 Switch Test	8
3-4-2 Sound Test	9
3-4-3 Coin Options	10
3-4-4 Game Options	10
3-4-5 Factory Settings.....	11
3-5 PC Board Connectors	12
4. PARTS	13
5. SCHEMATIC	14

1. SPECIFICATIONS

POWER SUPPLY :-	220/240volts AC																		
COIN ACCEPTOR:-	Mars CashFlow - 1 Channel																		
MONITOR :-	Hantarex 28" Polo Colour Monitor with auto degauss.																		
DIMENSIONS :-	790(w) x 1200(d) x 2080(h)																		
WEIGHT :-	175kg.																		
ACCESSORIES :-	<table border="0"> <tr> <td>Keys:</td> <td>(Cash Door)</td> <td>2</td> </tr> <tr> <td></td> <td>(Coin Door)</td> <td>2</td> </tr> <tr> <td></td> <td>(Back Door)</td> <td>2</td> </tr> <tr> <td></td> <td>IEC Mains Lead</td> <td>1</td> </tr> <tr> <td></td> <td>Operators Manual</td> <td>1</td> </tr> <tr> <td></td> <td>Monitor Manual</td> <td>1</td> </tr> </table>	Keys:	(Cash Door)	2		(Coin Door)	2		(Back Door)	2		IEC Mains Lead	1		Operators Manual	1		Monitor Manual	1
Keys:	(Cash Door)	2																	
	(Coin Door)	2																	
	(Back Door)	2																	
	IEC Mains Lead	1																	
	Operators Manual	1																	
	Monitor Manual	1																	

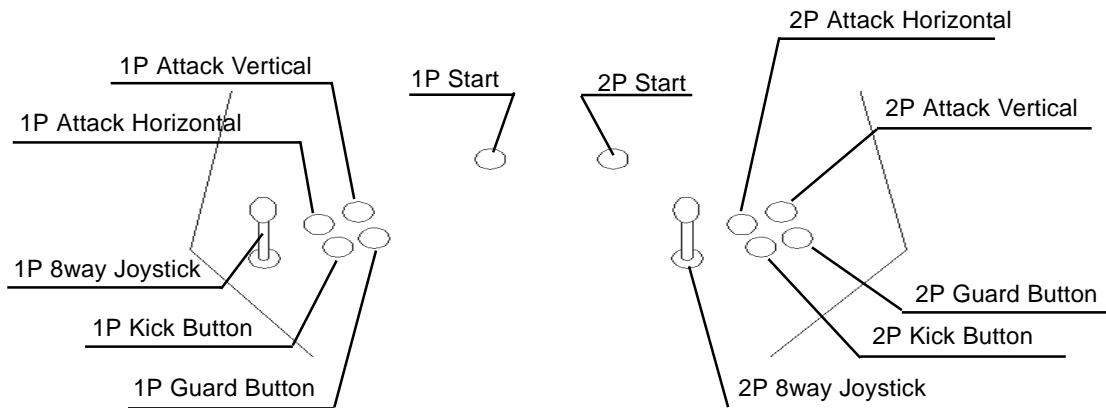

2. PRECAUTIONS

2-1 Cautions When Installing.

This game is designed for indoor use only. The game must not be installed outdoors or under the following conditions:-

- a. In areas directly exposed to sunlight, high humidity, direct water contact, dust, high heat or extreme cold.
- b. In locations that would present an obstacle in the case of an emergency, i.e. near fire equipment or emergency exits.
- c. On an unstable surface or subject to floor vibration.

2-2 Cautions when Handling.

- a. AC power must always be turned OFF, and the game disconnected, before replacing any parts or connecting/disconnecting connectors.
- b. When unplugging the game from an electrical outlet, always grasp the plug, not the mains lead.
- c. The machine must be earthed with a securely connected earthed plug.
- d. Care must be taken at all times to avoid electric shock when inspecting or adjusting the game.

2-3 Cautions when Transporting.

- a. Do not subject the game to physical shock when transporting or moving it.
- b. Always return the levellers to the UP position before moving the machine.
- c. Take care not to rope any moulded (plastic) parts when transporting.

2-4 Cautions when handling the PCB.

- a. Never test the PCB for continuity with a multimeter or similar device. The PCB contains sensitive devices which could be damaged or even destroyed by the internal voltage of such test equipment.
- b. Foreign matter or dust on the PCB may cause failure. Turn off the power and clean the PCB with a dry soft brush.
- c. When transporting the PCB ensure adequate packing protection to prevent damage.

3. ADJUSTMENTS

3-1 Turning on the Power

After installing the machine, turn on the power. The power switch is located above the mains inlet on the rear of the cabinet.

3-2 Switches for Adjustment

Open the coin door to find the switches for adjustments, located on the service bracket.

1. Service Switch
Press this switch to obtain game credits without incrementing the coin counter.
2. Test Switch
Slide this switch "ON" to enter test mode.
Test mode allows game testing and the changing of game settings.
(See "3-4 Test Mode" on page 8)

There are two DIP switches located on the PCB.
Switch 1 when set ON will enter the game into test mode. Always ensure this switch is set to OFF and use the test switch on the service bracket for testing the machine. Switch 2 when set ON will freeze the screen.

3-3 Volume Adjust

The volume control is located on the PCB. Turn the control to increase or decrease the volume.

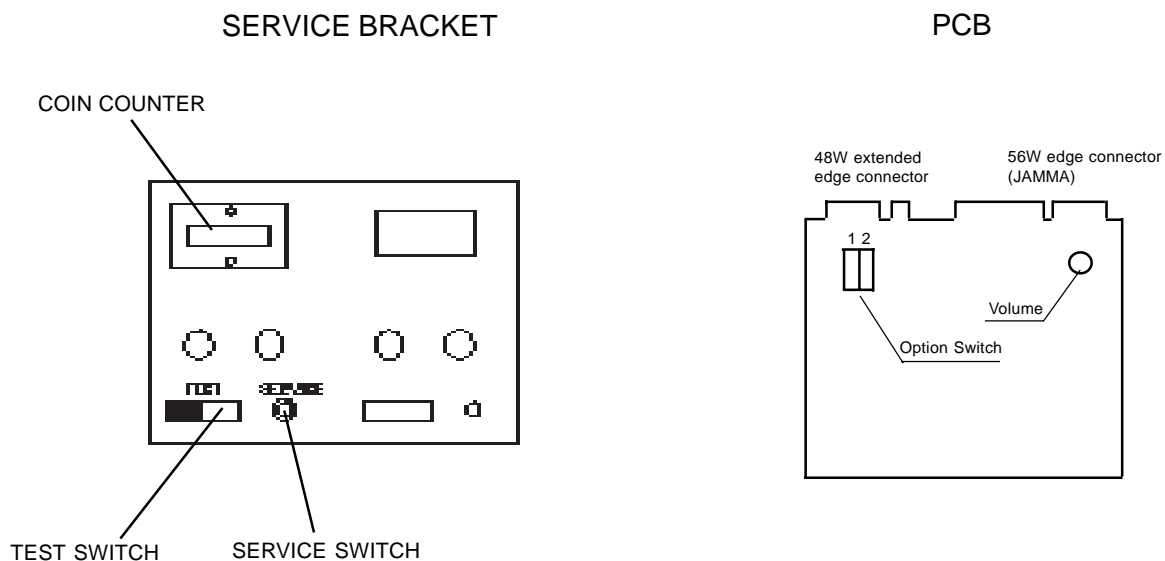

3-4 Test Mode

1. Open the coin door for access to the service bracket, then slide the test switch "ON". The "Test Menu Screen" will appear on the monitor display.
2. Operating the 1 Player joystick up or down will step through the items.
3. Pressing the 1 Player Attack (H) Button will select an item.
4. Operating the 1 Player joystick up or down will change the settings.
5. Pressing the 1 Player Attack (H) Button will store the change.
6. Pressing the 1 Player Attack (V) Button will return the display to the Test Menu Screen.

The test switch must always be "OFF" during normal game mode.

SWITCH TEST	For testing switches
SOUND TEST	For testing the sound
COIN OPTIONS	For setting game pricing
GAME OPTIONS	For setting of difficulty etc.
UARTS TEST	Not Used
POLYGON TEST	For testing graphics
A.D.S	Not Used
COLOR TEST	For monitor set-up
CONVERGENCE TEST	For monitor set-up
RS-232C TEST	Not Used

Test Menu Screen

3-4-1 Switch Test

On entering the switch Test, the following screen appears on the monitor.

Operating the joysticks will cause the + to change to X for each of the eight positions.

When testing:

1P Attack (H) 1P 0000 will change to 1P 1000
1P Attack (V) 1P 0000 will change to 1P 2000
1P Kick 3P 0000 will change to 3P 1000
1P Guard 3P 0000 will change to 3P 2000
2P Attack (H) 2P 0000 will change to 2P 1000
2P Attack (V) 2P 0000 will change to 2P 2000
2P Kick 4P 0000 will change to 4P 1000
2P Guard 4P 0000 will change to 4P 2000

Pressing 1P Attack (V) will return to the Test Menu Screen

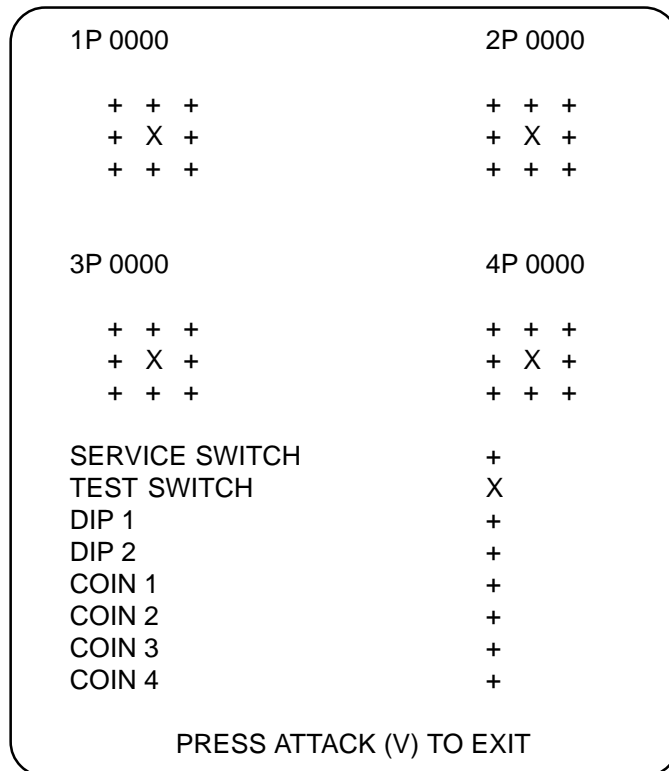

3-4-2 Sound Test

On entering the Sound Test, the following display will appear on the monitor.

Pushing the 1 player joystick to the right will make the number step up and pushing the joystick to the left will make the number step down.

Each number will produce a different sound when the 1 player Punch 1 button is pressed.

Song 001 will produce a tone first on the left speaker, then on the right speaker and then on both speakers together.

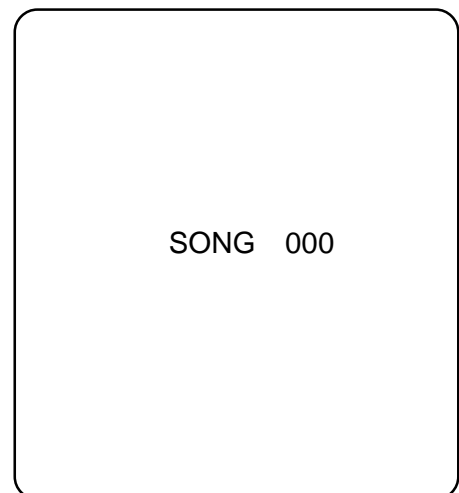

3-4-3 Coin Options

Note:- The price of play on this machine is set within the CashFlow coin mech.
Ensure that the coin options on the screen are set as shown in the following table.

GAME OPTIONS	
GAME COST -----	(1)
1 COIN 1 CREDIT	
DISCOUNT TO CONTINUE -----	(2)
NO	
COIN 1 MECH VALUE -----	(3)
1 COIN COUNT AS 1 COIN	
COIN 2 MECH VALUE -----	(4)
1 COIN COUNT AS 1 COIN	
COIN 3 MECH VALUE -----	(5)
1 COIN COUNT AS 1 COIN	
COIN 4 MECH VALUE -----	(6)
1 COIN COUNT AS 1 COIN	
BONUS FOR QUANTITY BUY-IN -----	(7)
NONE	
CREDIT MODE -----	(8)
COMMON	
COIN COUNTER -----	(9)
TYPE A: 1 COUNTER	
FREE PLAY -----	(10)
NO	

Coin Option Screen

3-4-4 Game Options

GAME OPTIONS	
DIFFICULTY LEVEL : HARD -----	(11)
STAGE WIDTH : 18 M -----	(12)
FIGHT COUNT(1P GAME) : 2 -----	(13)
FIGHT COUNT (2P GAME) : 2 -----	(14)
LIFE BAR (1P GAME) : 110% -----	(15)
LIFE BAR (2P GAME) : 125% -----	(16)
GUARD DAMAGE : OFF -----	(17)
ROUND TIME : 40sec -----	(18)
CHARACTER CHANGE AT CONTINUE : YES -----	(19)
CHARACTER CHANGE AT 2P GAME : YES -----	(20)
MUSIC IN ATTRACT : YES -----	(21)
SPEAKER OUT : STEREO -----	(22)
EVENT MODE : OFF -----	(23)
HIT COLOUR : GREEN -----	(24)

Game Option Screen

3-4-5 Factory Settings

ITEM		CONTENTS	FACTORY SET
1	GAME COST	COIN PULSES REQUIRED FOR CREDIT ----- settable 1 - 9	1
2	DISCOUNT	50% DISCOUNT FOR CONTINUE ----- YES / NO	NO
3	COIN 1 MECH VALUE	NUMBER OF PULSES ON METER ----- settable 1 - 9	1
4	COIN 2 MECH VALUE	NUMBER OF PULSES ON METER ----- settable 1 - 9	1
5&6		NOT USED	
7	BONUS COIN	EXTRA COIN PULSE AT SPECIFIED COINS IN	NONE
8	CREDIT MODE	COMMON (Credit common to player 1 & 2) / EACH ONE (Player 1 & 2 seperate)	COMMON
9	COIN COUNTER	TYPE A (1 Coin Counter) / TYPE B (2 Coin Counters)	TYPE A
10	FREE PLAY	YES / NO	NO
11	DIFFICULTY LEVEL	EASY / MEDIUM / HARD / VERY HARD / ULTRA HARD	HARD
12	STAGE WIDTH	SETS THE SIZE OF COMBAT AREA	18 M
13	FIGHT COUNT (1P GAME)	Settable 1 - 4	2
14	FIGHT COUNT (2P GAME)	Settable 1 - 4	2
15	LIFE BAR (1P GAME)	95 / 110 / 125 / 140 / 160	110
16	LIFE BAR (2P GAME)	95 / 110 / 125 / 140 / 160	125
17	GUARD DAMAGE	OFF / ON (ON : A Character is damaged a little even when blocking)	OFF
18	ROUND TIME	20sec / 30sec / 40sec / 50sec / 60sec	40sec
19	CHARACTER CHANGE AT CONTINUE	YES/NO	YES
20	CHARACTER CHANGE AT 2P GAME	YES / NO	YES
21	MUSIC IN ATTRACT	YES / NO	YES
22	SPEAKER OUT	STEREO / MONO	STEREO
23	EVENT MODE	OFF / ON (Game is over per each 2P game)	OFF
24	HIT COLOUR	GREEN / RED	GREEN

3-5 PC Board Connectors

JAMMA 56way Edge Connector			
Solder Side	Terminal No		Part Side
GND	A	1	GND
GND	B	2	GND
+5v	C	3	+5v
+5v	D	4	+5v
	E	5	
+12v	F	6	+12v
Polarizing Key	H	7	Polarizing Key
Coin Counter 2	j	8	Coin Counter 1
	K	9	Coin Lockout
Speaker (-)	L	10	Speaker (+)
Audio (GND)	M	11	Audio (+)
Video GREEN	N	12	Video RED
Video SYNC	P	13	Video BLUE
Service Switch	R	14	Video GND
	S	15	Test Switch
Coin Switch 2	T	16	Coin Switch 1
2P Start Switch	U	17	1P Start Switch
2P Lever UP	V	18	1P Lever UP
2P Lever DOWN	W		1P Lever DOWN
2P Lever LEFT	X		1P Lever LEFT
2P Lever RIGHT	Y		1P Lever RIGHT
2P Attack - H	Z	22	1P Attack - H
2P Attack - V	a	23	1P Attack - V
2P Kick	b	24	1P Kick
	c	25	
	d	26	
GND	e	27	GND
GND	f	28	GND

- Do not make connections to blank positions.
- Lockout / Coin Counter both operate on +12v.
- The supply voltage must be within 5%.
- +5V / 2.5A minimum
- +12v / 2A minimum

48w Extended Edge Connector			
Solder Side	Terminal No		Part Side
Speaker R (-)	A1	B1	Speaker R (+)
	A2	B2	
	A3	B3	
	A4	B4	
Polarizing Key	A5	B5	Polarizing Key
	A6	B6	
	A7	B7	
2PGuard Button	A8	B8	
	A9	B9	GND
	A10	B10	GND
	A11	B11	
	A12	B12	
	A13	B13	
	A14	B14	
	A15	B15	
	A16	B16	
	A17	B17	
	A18	B18	
	A19	B19	
1P Guard Button	A20	B20	
	A21	B21	
	A22	B22	
	A23	B23	
	A24	B24	

Speaker Connections

- Connect the (L) speaker to the speaker output of the 56w JAMMA connector
- Connect the (R) speaker to the Speaker R (+) & (-) of the 48w Extended connector

4. PARTS

Decals & Plastics

DESCRIPTION	PART No.
Cabinet Decal LHS - Upper	40000290
Cabinet Decal LHS - Lower	40000291
Cabinet Decal RHS - Upper	40000292
Cabinet Decal RHS - Lower	40000293
Cabinet Decal Front - LHS	40000294
Cabinet Decal Front - RHS	40000295
Cabinet Decal "NAMCO" LHS/RHS/Front	40000061
Character Plexi	30000225
Play Panel Overlay	33000120
Header Box Vac-Form	45000728
Top Flash Acrylic	30000226

Cabinet

DESCRIPTION	PART No.
Monitor 28" Hantarex	84000026
Front Glass - Bronze	31000022
Interlock Switch	60000006
Interlock Switch Cover	39000028
M16 Adjustable Foot	88300079
Switch Mode Power Supply	83000002
Mains Filter	67000303
Speaker 4½" 20w (with shield can)	62000006
Schaffner Mains In Assy	66000016
Schaffner Boot	66000017
Fuse 5amp 20mm Slo-Blo	63500600
18" 15w Fluorescent Tube	64500009
Choke 240v 15w	63300000
Starter	63000000
Service Switch - SPNO	60000059
Test Switch - DPCO	60000023
3.5 - 6v Panel Meter	65000002
Joystick 8way Brent Fast Action Type	61000017
Push Button - Yellow	60200266
Push Button - Green	60200267
Push Button - Red	60200264
Push Button - Blue	60200263
Push Button - White	60200262

5. SCHEMATIC

