

namco[®]

RIDGE RACER[™]
UPRIGHT

Operators Manual

© **namco**[®] Ltd - all rights reserved.

No part of this publication may be reproduced by any mechanical, photographic or electronic process, or in the form of phonographic recording, nor may it be stored in a retrieval system, transmitted or otherwise copied for public or private use, without permission from **namco** Ltd.

Published by:
BRENT LEISURE Ltd.
Unit 1 Brent Crescent,
London. NW10 0QT

Phone:- 081-965-0550
Fax:- 081-961-0574

Contents

Operators Manual	1
1. SPECIFICATIONS	4
2. PRECAUTIONS	5
2-1 Cautions When Installing.	5
2-2 Caution when Handling.	5
2-3 When Transporting.	5
3. ADJUSTMENTS	6
3-1 Turning on the Power	6
3-2 Switches for Adjustments	6
3-3 Test Mode	7
3-3-1 Setting the Game Fee and So On (On the Coin Options Screen)	8
3-3-2 Changing the Game Settings (on the Game Options Screen)	9
3-3-3 Switch Test	10
3-3-4 Sound Test (Adjusting the Sound Volume)	11
3-4 Adjusting the Game After Replacing Parts (Initializing the Game) .	12
4. HOW TO PLAY	13
5. MAINTENANCE	14
5-1 Removing the Game Printed Circuit Board (PCB)	14
5-2 Removing the Shield Case	15
5-3 Removing the Power Control Panel	15
5-4 AB Pedal Assy (Replacing the Control)	15
5-5 Gear Shift Assy (removing)	15
5-6 Steering Assy	16
5-6-2 Replacing The Steering Wheel.....	16
6. PARTS	17
7. SCHEMATIC	19

1. SPECIFICATIONS

POWER SUPPLY :- 220/240volts AC

MONITOR:- Hantarex 26" Polo Colour Monitor with auto
degauss

DIMENSIONS :- 1205(w) x 895(d) x 1900(h)

WEIGHT :- 140kg.

ACCESSORIES :-

- Keys: (Cash Door) 2
- (Coin Assy) 2
- ((Back Door) 2

- Operators Manual 1

- IEC Mains Lead 1

2. PRECAUTIONS

2-1 Cautions When Installing.

This game is designed for indoor use only. The game must not be installed outdoors or under the following conditions:-

- a. In areas directly exposed to sunlight, high humidity, direct water contact, dust, high heat or extreme cold.
- b. In locations that would present an obstacle in the case of an emergency, ie. near fire equipment or emergency exits.
- c. On an unstable surface or subject to floor vibration.

2-2 Caution when Handling.

- a. AC power must always be turned OFF, and the game disconnected, before replacing any parts or connecting/disconnecting connectors.
- b. When unplugging the game from an electrical outlet, always grasp the plug, not the mains lead.
- c. The machine must be earthed with a securely connected earthed plug.
- d. Care must be taken at all times to avoid electric shock when inspecting or adjusting the game.
- e. Adjustment is required whenever the game PCB board, ROM, Steering Assy, AB Pedal Assy or Controls are replaced. [See "3-4 Adjusting the Game after Replacing Parts" on page 12](#)

2-3 When Transporting.

- a. Do not subject the game to physical shock when transporting or moving it.

3. ADJUSTMENTS

3-1 Turning on the Power

After installing the product, turn on the power. The power switch is located above the mains inlet on the rear of the main body.

3-2 Switches for Adjustments

Open the coin door to find the switches for adjustments.

1. Service switch.

Press this switch to increase the number of credits without incrementing the coin counter.

2. Test switch.

Set this switch to "ON" to enter test mode.

You can change the game fee and so on, and perform various tests in Test mode.

(See "3-3 Test Mode" on page 7).

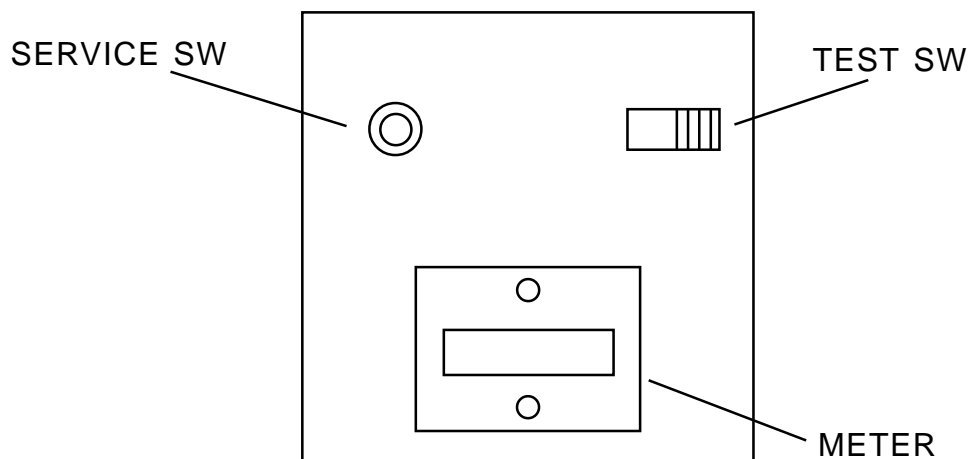

3-3 Test Mode

1. Open the coin door, then set the test switch to "ON". The "Menu Screen" appears on the monitor display.
2. Select the item to be tested by turning the steering wheel right or left. The colour of the item you selected changes.
3. Step on the accelerator pedal to display the menu of the selected item. To return to the "Menu Screen", step on the brake pedal (step on both the brake and clutch pedals on the Switch Test Screen).
4. When the test finishes, set the test switch to "OFF" to return to the Game Screen.

The Test switch must always be "OFF" during normal game mode.

MENU	
COIN OPTIONS —	(1) For setting the price of play (See 3-3-1)
GAME OPTIONS —	(2) For setting the game options (See 3-3-2)
BOARD TEST —	(3) For testing the game PCB
SWITCH TEST —	(4) For testing switches (See 3-3-3)
SOUND TEST —	(5) For adjusting the sound volume (See 3-3-4)
MONITOR TEST —	(6) For monitor adjustments
ADS TEST —	(7) For displaying the game data collected
ABOUT —	(8) For restoring each setting to standard value
IN = STEP ON THE GAS	

3-3-1 Setting the Game Fee and So On (On the Coin Options Screen)

Select 1 "COIN OPTIONS" on the Menu Screen to set the game fee and so on.

Turn the steering wheel to select the item to be changed, then step on the accelerator pedal.

Turn the steering wheel again to change the setting, then step on the accelerator pedal (See table 1.)

Step on the brake pedal to return to the Menu Screen.

COIN OPTIONS	
GAME COST 2 COINS 1 CREDIT	(a)
COIN 1 MECH VALUE 1 COIN COUNT AS 1 COIN	(b)
COIN 2 MECH VALUE 1 COIN COUNT AS 1 COIN	(c)
BONUS FOR QUANTITY BUY-IN NONE	(d)
FREE PLAY OFF	(e)
EXIT = STEP ON THE BRAKE	

Note: *The price of play adjustments are made on the credit board and the coin options should be set as the following table.*

Item	Description		
(a) Game fee	Number of credit pulses necessary for game credit	One to nine	Set to 1
(b) Coin 1 mechanism	Number of credit pulses per coin	One to nine	Set to 1
(c) Coin 2 mechanism	Not Used	One to nine	
(d) Bonus	The extra credit given as a bonus when the specified number of coins are inserted	One credit per one coin Three credits per nine coins	Set to NONE
(e) Free play	Free play started by stepping on the accelerator	OFF/ON	set to OFF

3-3-2 Changing the Game Settings (on the Game Options Screen)

Select 2 “GAME OPTIONS” to change the game options.

Turn the steering wheel to select the item to be changed then step on the accelerator pedal.

Turn the steering wheel again to change the setting, then step on the accelerator pedal (see table 2).

Step on the brake pedal to return to the Menu Screen.

GAME OPTIONS			
(DEFAULT IN GREEN)			
<u>GAME</u>	<u>DIFFICULTY</u>	<u>TIME</u>	<u>EXTEND</u>
	NOVICE	D	** ** ** *
	ADVANCED	D	** ** ** *
	EXPERT	D	** ** ** *
	T.T.	D	** ** ** *
<u>LAP</u>			
	NOVICE	2	_____
	ADVANCED	3	_____
	EXPERT	3	_____
	T.T.	3	_____
<u>SPEED</u>		KM/H	_____
<u>SOUND IN ATTRACT</u>		ON	_____
EXIT = STEP ON THE BRAKE			

Settings of the Game Options Screen

Item	Description	Factory setting
(a) Play time for the novice level	A (shortest) to H (longest)	D
(b) Play time time for the advanced level	A (shortest) to H (longest)	D
(c) Play time for the expert level	A (shortest) to H (longest)	D
(d) Play time for the time trial game	A (shortest) to H (longest)	D
(e) Laps for the novice level	2 to 5	2
(f) Laps for the advanced level	2 to 5	3
(g) Laps for the expert level	2 to 5	3
(h) Laps for the time trial game	2 to 5	3
(i) Unit of speed	KM/H (kilometer) Set for country of use MPH (Mile)	
(j) Attract sound	ON/OFF	ON

3-3-3 Switch Test

Select 3 "SWITCH TEST" to display the following screen.

SWITCH TEST	
DIP SW2	12345678
SW3	12345678
STEERING	*0000
GAS	*0000
BRAKE	*0000
CLUTCH	OFF
SHIFT	N SWITCH 1 OFF
	SWITCH 2 OFF
	SWITCH 3 OFF
	SWITCH 4 OFF
SERVICE	OFF
COIN 1	OFF
COIN 2	OFF
EXIT = STEP ON THE BRAKE AND ACCELERATOR	

- (a) Option switch (SW2 on the CPU)
- (b) Option switch (SW3 on the CPU)
- (c) Steering
- (d) Accelerator
- (e) Brake
- (f) Clutch
- (g) Shift
- (h) Service switch
- (i) Coin 1 switch
- (j) Coin 2 switch

- a. The status of the option switch SW2 on the game PCB (CPU-PCB) is indicated here.
- b. The status of the option switch SW3 on the game PCB (CPU-PCB) is indicated here.
The SW2 or SW3 switch is set to ON when the corresponding number is red.
- c. When you turn the steering wheel to the right, the number increments. When turning it to the left, the number decrements.
- d. When you step on the accelerator pedal, the number increments.
- e. When you step on the brake pedal, the number increments. An approximate value of "0000" appears on the item c, d or e respectively when you locate the steering wheel in the middle and when the accelerator and brake pedals are released. (Even if the least digit of the number changes, the game is operating normally). "OK" appears to the right of the number when the accelerator and brake pedals are depressed.
- f. "ON" appears when you depress the clutch pedal.
- g. The position of the shift (1 to 6, N) and the status of four switches are indicated here.
When you move the shift lever forwards, the switch 1 is set to ON. When you move it backwards, the switch 2 is set to ON. When you move it to the left direction, the switch 3 is set to "ON". When you move it to the right direction, the switch 4 is set to ON.
- h. "ON" appears when you press the service switch inside the coin door.
- i. "ON" appears when you operate the coin 1 switch.
- j. Not used.

To return to the Menu Screen, step on both the brake and gas pedal at the same time

3-3-4 Sound Test (Adjusting the Sound Volume)

Select "SOUND TEST" on the menu screen to adjust the sound volume. The following screen appears.

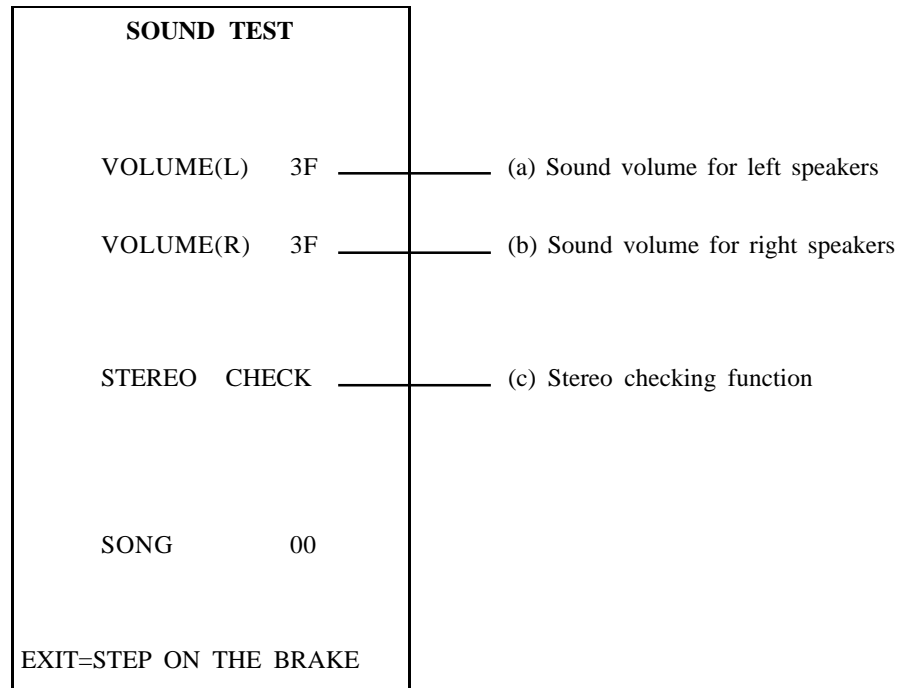

Use the steering wheel to select the item to be changed. Step on the accelerator and the item selected will stop flashing. Use the steering to adjust the level. Step on the accelerator when the desired setting is reached and the item will start flashing. The steering can now select another item.

The sound volume can be adjusted in 64 steps between 00 (minimum) to 3F (maximum). The factory setting is "3F". (i.e. Loudest)

When you select (c) and step on the accelerator pedal, sound is produced the left speaker, then the right speaker. Step on the brake pedal to return to the Menu Screen.

3-4 Adjusting the Game After Replacing Parts (Initializing the Game)

Be sure to adjust the game with the following the instructions below after replacing any part. Otherwise, the game will not function correctly.

1. Ensure that the accelerator and brake pedals are released and the steering is in the centre.
2. Hold down the service switch and slide to the test switch to “ON”. The

ADJUST	
STEERING	0000
GAS	0000
BRAKE	0000

following screen appears on the monitor display.

3. To zero the settings press the service switch.
4. When each number on the right hand side of the items: STEERING, GAS and BRAKE is about “OOOO”, the adjustments are complete.
5. Set the test switch to “OFF” to return to the Game Screen.

The test switch must always be “OFF” during normal game mode.

4. HOW TO PLAY

- This is **the** car race game.
- Four difficulties are provided: NOVICE, INTERMEDIATE, ADVANCED and T.T. (Time Trial)

(Outline of a Game)

- When a player drives a car the specified number laps within the given time, he or she finishes the race, the ranking, lap time and total time are displayed and the game is over.
- If the remaining time becomes “O” before a player finishes the race, the game is over.

(Starting a Game)

- Insert coins, then select the difficulty. Turn the steering wheel to select the difficulty from NOVICE, INTERMEDIATE, ADVANCED and TT, then step on the accelerator pedal to set it.
- If a player does not select the above items within 10 seconds, the game sets its choices by itself.

(Difference of the Difficulty Levels)

- When a player selects the NOVICE level, he or she drives a car on the MAIN COURSE at a low speed. This is the player’s car vs. computer driven cars race game.
- When a player selects the INTERMEDIATE level, he or she drives a car on the MAIN COURSE at a high speed. This is the player’s car vs. computer-driven cars race game.
- When a player selects the ADVANCED level, he or she drives a car on the MAIN COURSE and a TECHNICAL BRANCH at a high speed. This is the player’s car vs. computer-driven cars race game.
- When a player selects the TT level, he or she drives a car on the MAIN COURSE and the TECHNICAL BRANCH at a higher speed than that of the ADVANCED level. This is the player’s car vs. a computer-driven car time trial race. When a player clocks a good time, they can record their name.

5. MAINTENANCE

5-1 Removing the Game Printed Circuit Board (PCB)

1. Remove the back door,
2. Remove two assembling bolts (M6 X 30), then pull out the power control panel about 25cm. (Note: if you pull it out too much, it will be detached).
3. Disconnect two connectors on the EMI board, then remove six cup screws (M4 X 10) from the shield case door. (Do not lose internal washers).
4. Take care not to damage the connectors between the EMI board and the main PCB to remove the shield case door, then take out the main pcb.
5. Remove two cup screws (M4 X 10) from the I/O door. (Note: Do not remove other screws).
6. Remove the I/O door, then disconnect four connectors of the I/O PCB.
7. Take out the I/O PCB.

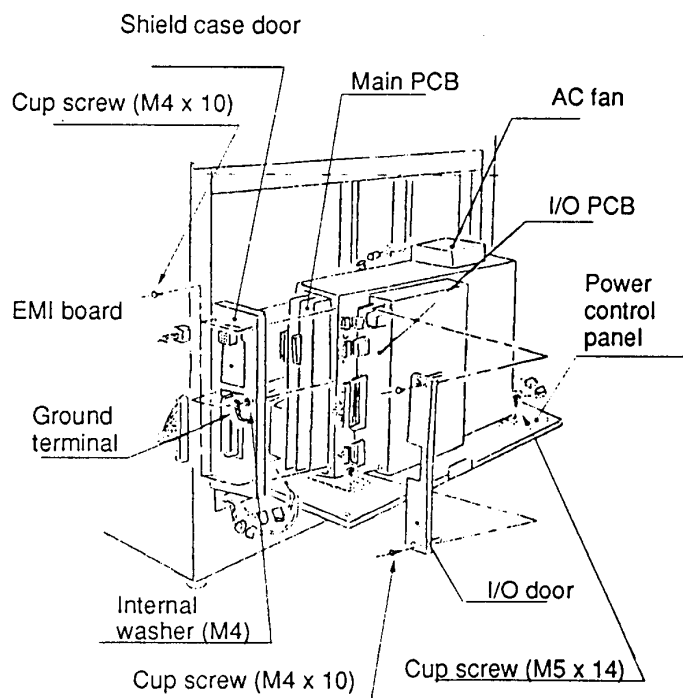
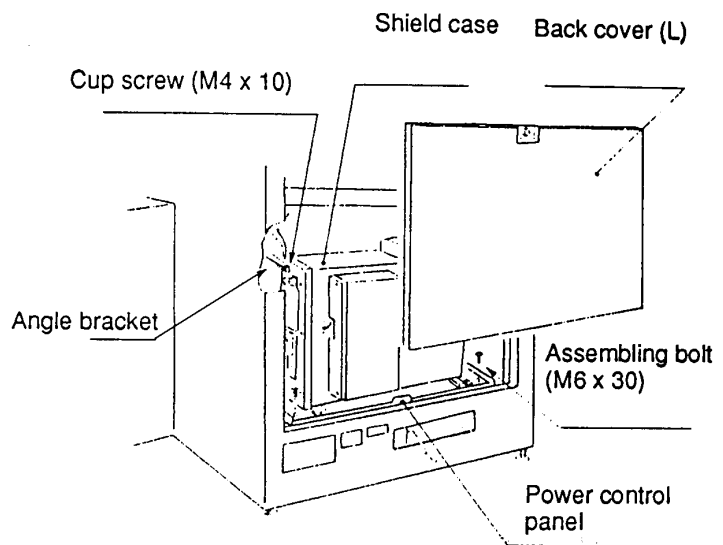

5-2 Removing the Shield Case

1. Perform Steps (1) and (2) described in [Section 5-1](#).
2. Disconnect the connector of the AC Fan.
3. Remove two cup screw (M5 X 14) then take out the shield case.

5-3 Removing the Power Control Panel

- 1 Perform steps 1, 2, 5 and 6 described in [Section 5-1](#).
2. Disconnect two connectors of the EMI board, remove a cup screw (M4 X 10) from the shield case door, then remove the ground terminal. (Note: do not lose the internal washer).
3. Disconnect the connectors connecting the power control panel and the main body assy: one connector on the right side and two connectors on the left side then remove the power control panel.

5-4 AB Pedal Assy (Replacing the Control)

1. Remove four hex head bolts (M6x20) and withdraw the assy forward .
2. Loosen the quadrant gear clamp screw and remove the quadrant gear.
3. Loosen the gear grub screw and remove the gear.
4. Replace the control potentiometer.

Note: When re-assembling

- a. Ensure that the potentiometer locating tag is engaged in the mounting plate cutout.
- b. *Turn the potentiometer shaft almost fully clockwise before engaging the quadrant gear.*

5-5 Gear Shift Assy (removing)

1. Open the play panel assy and disconnect the four way connector.
2. Remove four M4 coach bolts and withdraw the shifter assy.

5-6 Steering Assy

5-6-1 Replacing the control

1. Open the play panel assy to gain access to the steering assy.
2. Loosen the grub screw on the gear wheel and remove the gear wheel.
3. Replace the control potentiometer.
4. Replace the gear wheel and retighten the grub screw securely.

Note: When replacing the control potentiometer ensure that the locating tag of the potentiometer is located in the hole in the mounting bracket and the pot shaft is at its mid travel before tightening the gear grub screw.

5. Re-initialize the game ([See 3-4 Adjusting the Game - page 12](#)) before the game is played.

5-6-2 Replacing The Steering Wheel

1. Remove the centre cover of the steering wheel.
2. Remove three socket button heads (M6x16)
3. Pull off the steering wheel, then replace it with a new one.

6. PARTS

DESCRIPTION	PART No
Monitor 26" Hantarex Polo	84000010
Speaker 4 1/2" 20w (with shield can)	62000006
Dual Pedal Assy (with pots)	88800029
Dual Pedal & Steering Pot (5k)	76000652
Steering Assy (270 deg)	88800001
Gear Shift assy	88800009
Power supply Assy - 5v/30a	83000004
Schaffner Mains In Assy	66000016
Fuse 5a 20mm	63500601
Interlock Switch	60000006
Fan	67000015
Fluorescent Tube 18"	64500000
Choke 15w	63300000
Front Glass	31000008
Side Decal L.H.	40000033
Side decalR.H.	40000034
Play Instruction Plexi	45000161
Top Flash	30000028
Manual	90500009

270 deg Steering Assy

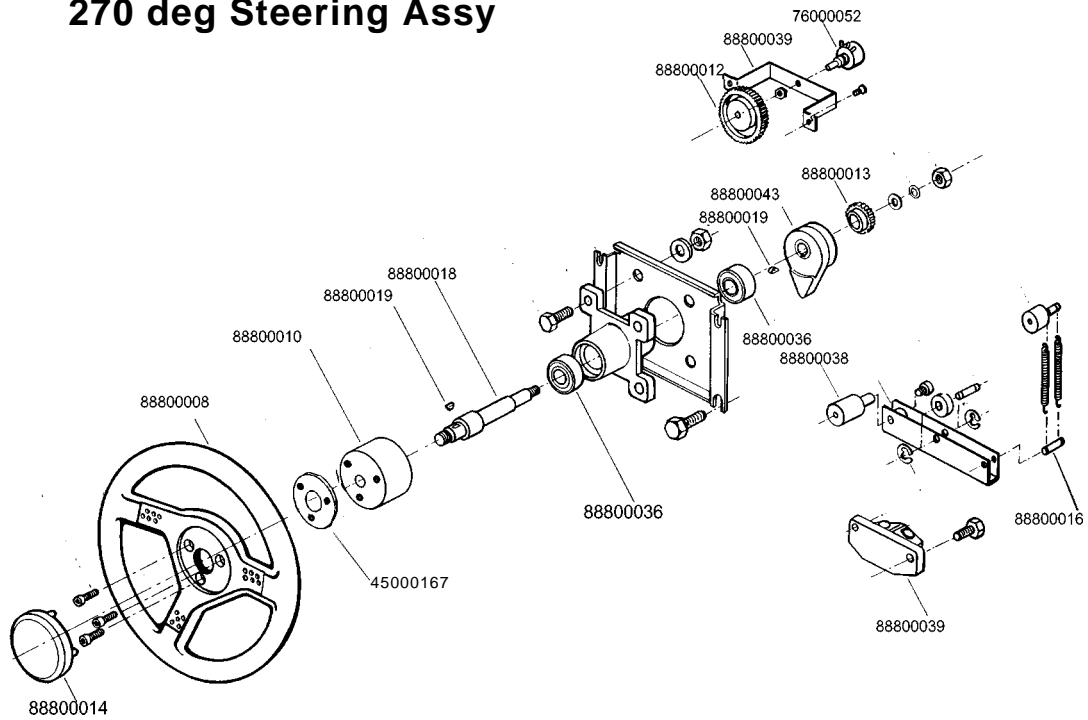

PART No	DESCRIPTION
88800008	Wheel Only
88800010	Adaptor
45000167	Steering Wheel Spacer
88800011	Spring
88800012	Gear - Large
88800013	Gear - Small
88800014	Steering Insert
76000052	5K Pot
88800016	Spring Link Shaft
88800018	Steering Shaft
88800019	Woodruff Key
88800035	Stop Unit
88800036	Steering Arm Bearing
88800037	Steering Arm
88800038	Spacer
88800039	Pot Bracket
88800043	Centre Cam Weight

7. SCHEMATIC

